



sistema de correr perimetral de 61mm

61mm perimetral sliding system

système coulissant périmétral de 61mm





## Características do Sistema

### System features

### Caractéristiques du système



O sistema de correr PL apresenta um melhoramento visual em relação às séries de correr tradicionais graças à robustez das suas uniões de 45°. A resistência mecânica do sistema PL permite-lhe ultrapassar com distinção as situações climáticas mais adversas. Associado a este sistema de correr o sistema de fecho multi-ponto oferece uma garantia extra contra a intrusão.

PL sliding system offers a visual enhancement when compared to the traditional sliding series due to the robustness of its 45° joining cuts. The mechanic resistance of the PL system is the basis for its meritorious endurance against adverse climate situations. This system combined with the multipoint locking system offers extra safety against intrusion.

Le système coulissant PL, comparé aux séries coulissants traditionnelles présente une meilleure visibilité grâce à ses jonctions à 45°. La résistance mécanique lui permet de supporter les conditions climatiques les plus dures. En associant à ce système coulissant le système de serrure multipoint assure une excellent protection contre le intrusion.

|                      |  |
|----------------------|--|
| <b>Apresentação:</b> | <b>Reta   Decorativa</b>   |
| Presentation         | Straight   Decorative  |
| Présentation         | Droite   Décorative  |
| <b>Dimensões:</b>    | <b>Aros Fixos: 2-rail: 61 mm</b>   |
| Dimensions           | Fixed frames   |
| Dimension            | Cadres dormants  |
|                      | <b>Aro Móvel: 34mm</b>   |
|                      | Mobile frame   |
|                      | Cadre ouvrant  |
| <b>Enchimento:</b>   | <b>De 6 a 22mm</b>   |
| Filling              | From 6 to 22mm   |
| Remplissage          | De 6 à 22mm  |
| <b>Envidraçado:</b>  | <b>Direto para vidro duplo</b>   |
|                      | <b>Redutor clipado para espessura de vidro inferior a 8mm</b>                      |
| Glass                | Direct for double glazing  |
|                      | Clipped reducer for glass thickness inferior to 8mm                                |
| Vitrage              | Direct pour double vitrage   |
|                      | Clip d'adaptation pour les verres dont l'épaisseur est inférieur à 8mm             |
| <b>Cortes:</b>       | <b>45°</b>   |
| Cuts                 | 45°  |
| Coupes               | 45°  |
| <b>Deslizamento:</b> | <b>Carrinhos simples ou duplos com rolamentos de agulhas sobre perfil posição</b>  |
| Sliding              | Simple or double needle rolling bearings on fake profile                           |
| Glissière            | Rails simples ou doubles avec roulements d'aiguilles sur le profil de recouvrement |
| <b>Vedação:</b>      | <b>Dupla pelúcia STOP FIN</b>  |
| Insulation           | Double STOP FIN plush  |
| Étanchéité           | Joints brosse double STOP FIN  |
| <b>Uniões:</b>       | <b>Esquadros de bloqueio de 14mm</b>   |
| Joint                | 14mm blocking brackets   |
| Union                | Équerres de verrouillage de 14mm   |
| <b>Peso máximo:</b>  | <b>150 Kg/folha</b>  |
| Maximum weight       | 150 Kg/leaf  |
| Poids maximale       | 150Kg/vantail  |
| <b>Acabamentos:</b>  | <b>Lacados   Anodizados</b>  |
| Finishes             | Powder coating   Anodizing   |
| Finitions            | Laqué   Anodisé  |



Licença nº. 1406 - Metalferr  
Licença nº. 1411 - Alfa Sul



Licença nº. 809

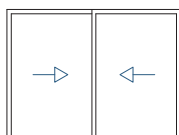

2 Rail

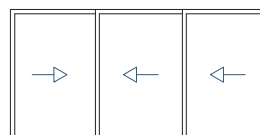

2 Rail

3 Rail

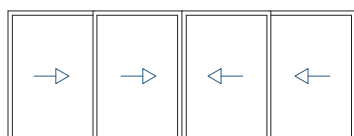

2 Rail

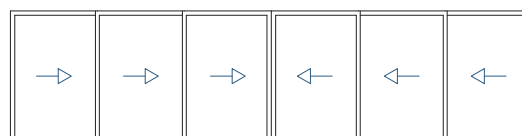

3 Rail

Desempenho do sistema  
System performance  
Performance du système

**Marcação CE**

CE Marking  
Marquage CE  
NP EN 14351-1

Janela 2 folhas com 2.00x2.25m

Vidro : 4 + 10 + 6

2 leaves window 2.00 x 2.25m

Glass: 4 + 10 + 6

Fenêtre 2 vantaux 2.00m x 2.25m

Verre: 4 + 10 + 6

**Permeabilidade ao AR**

AIR Permeability  
Perméabilité à l'AIR

**2**

**Estanquidade à ÁGUA**

WATER Tightness  
Étanchéité à l'EAU

**5A**

**Resistência ao VENTO**

WIND Resistance  
Résistance au VENT

**B2**

**Coef. Transm. TÉRMICA**

THERMAL Transmittance  
Coef. de Transmission THERMIQUE

**Uw = 3,38 W/m<sup>2</sup> K**

Ug = 1,6W/m<sup>2</sup> K (Janela 2 folhas com 2.20x2.40m)

Ug = 1,6W/m<sup>2</sup>K (2 leaves window with 2.20x2.40m)

Ug = 1,6W/m<sup>2</sup>K (Fenêtre de 2 vantaux avec 2.2x2.40m)

**Isolamento ACÚSTICO**

ACOUSTIC Insulation  
Isolation ACOUSTIQUE

**Rw (dB)= 30dB**

Rw (IGU) = 36dB, área ≤ 2,70m<sup>2</sup>

Rw (IGU) = 36dB, area ≤ 2,70m<sup>2</sup>

Rw (IGU)=36dB, aire ≤ 2,70m<sup>2</sup>

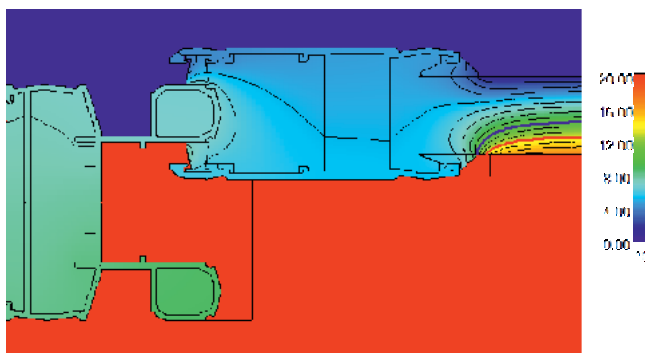
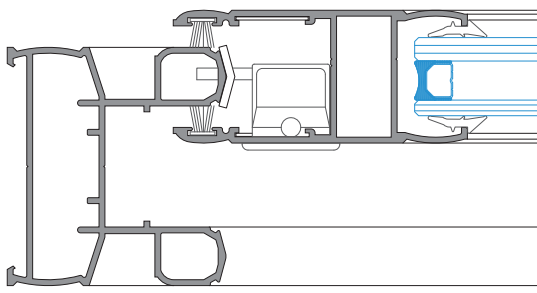



5

## Listagem de perfis

Profiles list  
Liste des profils

11

## Acessórios

Accessories  
Accessoires

21

## Pormenores de montagem

Assembly details  
Détails d'assemblage





Listagem de perfis

Profiles list

Liste des profils

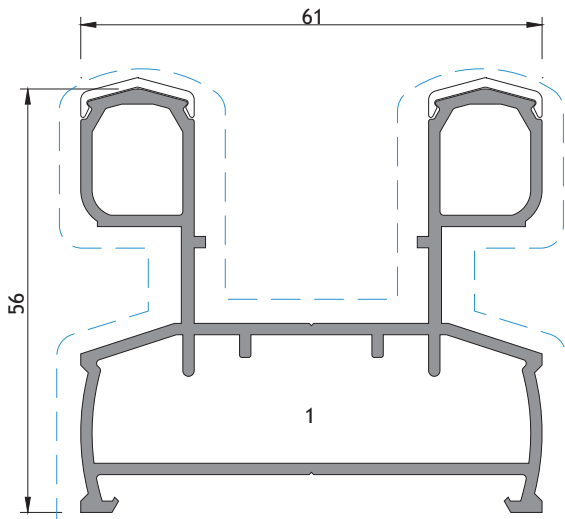

PL 05

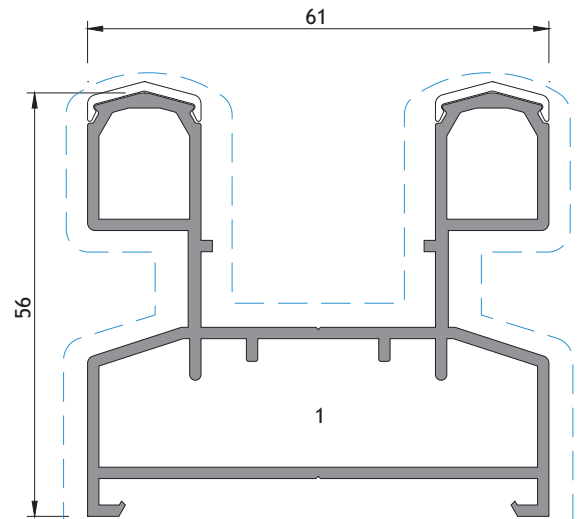

PL 55

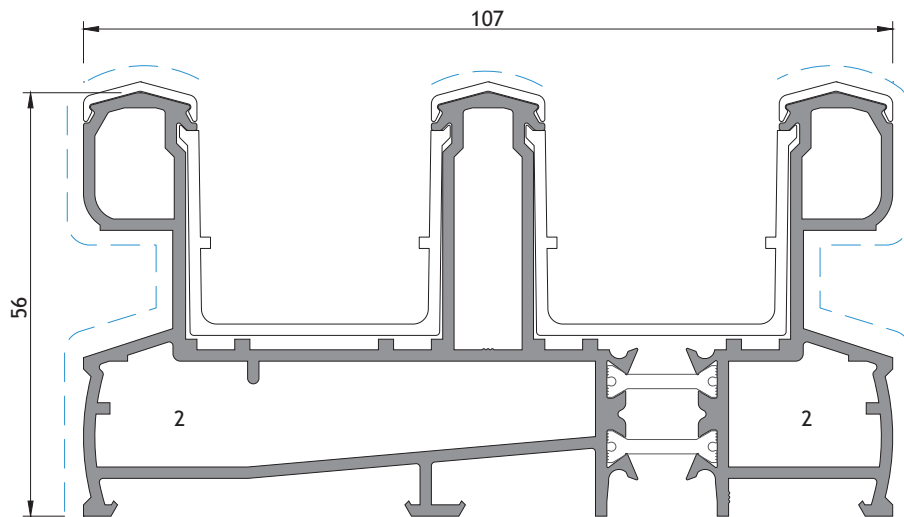

TL 72

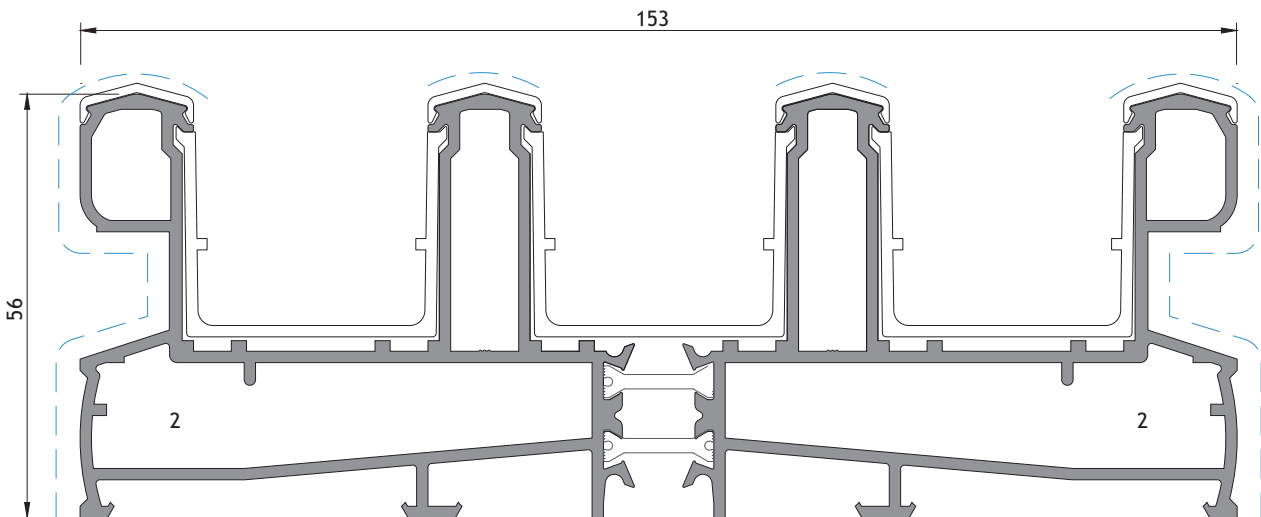

TL 74

1- ESQUADRO PL ESPECIAL PEQUENO

2 - ESQUADRO TL GRANDE

3- ESQUADRO AT ESPECIAL PEQUENO

4 - ESQUADRO TL 38 ESPECIAL PEQUENO



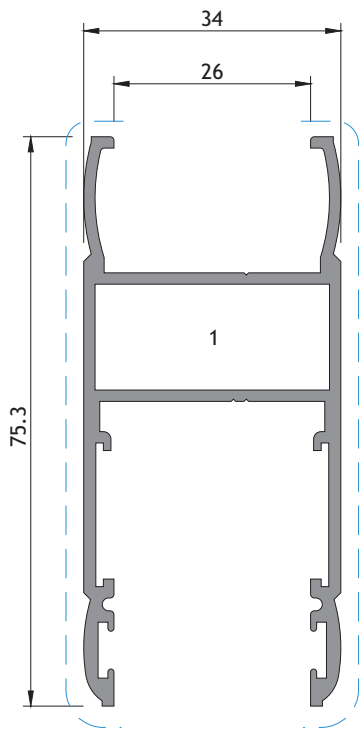

PL 17

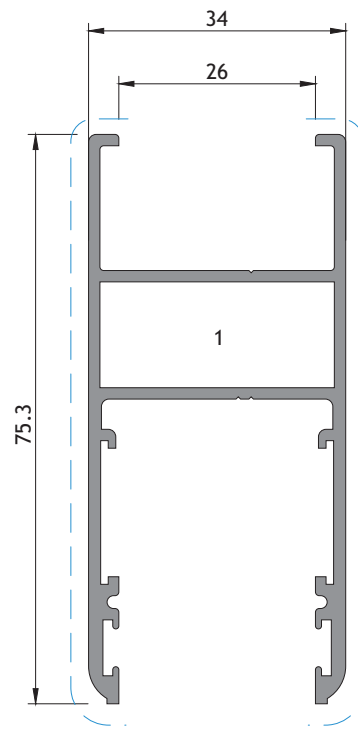

PL 57

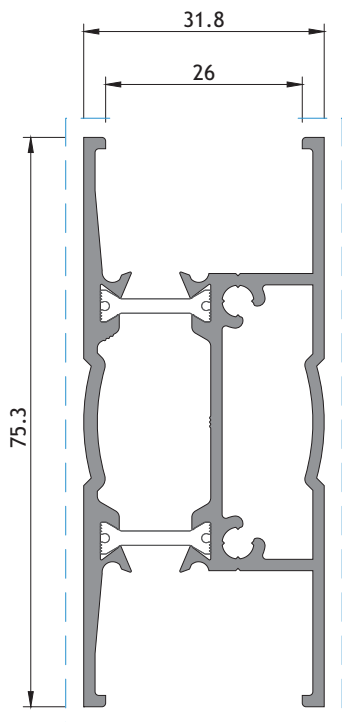

TL 18

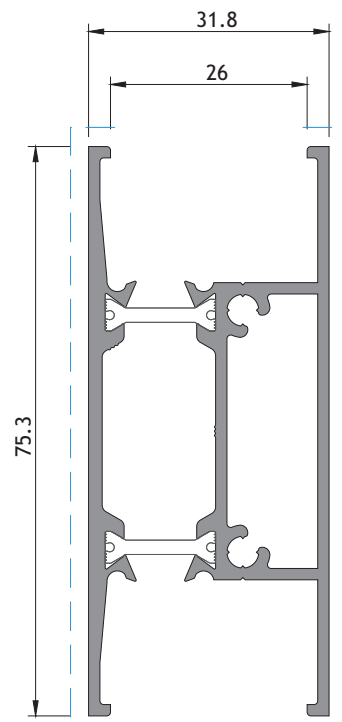

TL 58



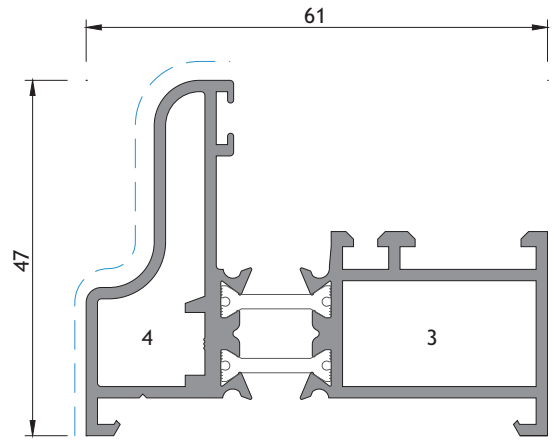

TL 38

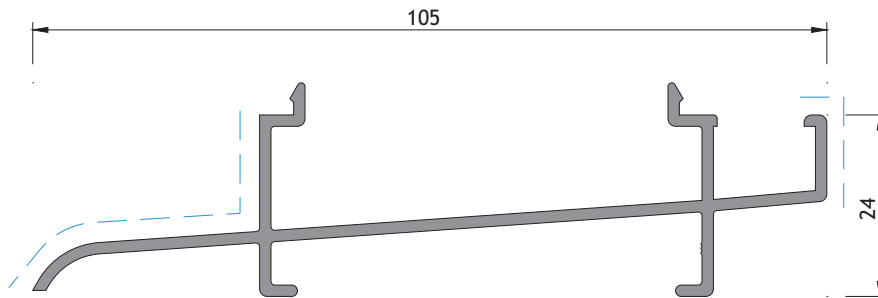

SP 26

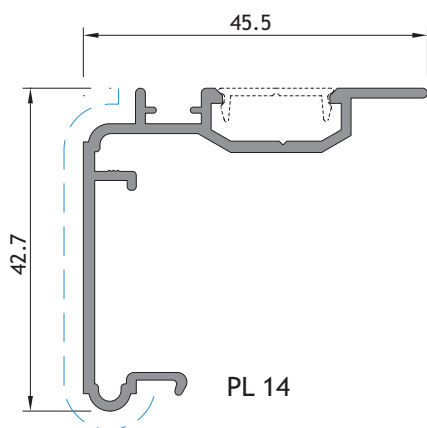

PL 14

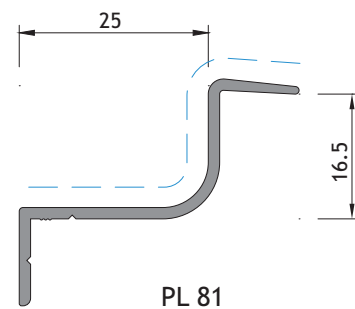

PL 81

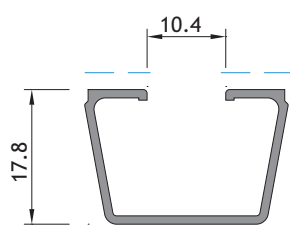

PL 24

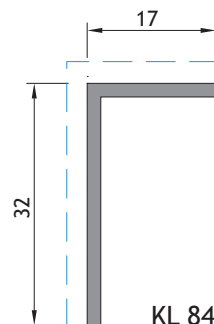

KL 84

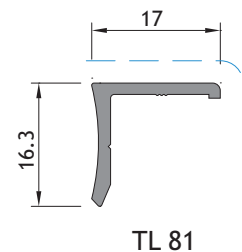

TL 81



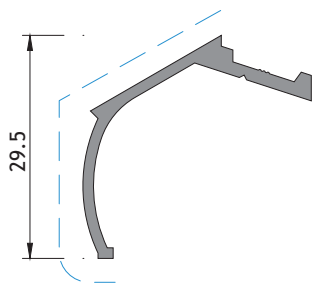

TL 80

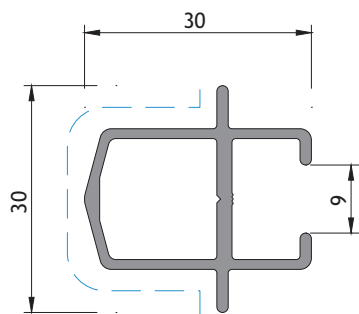

TL 27

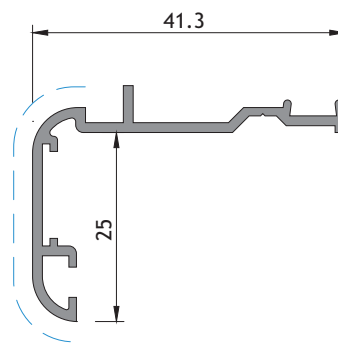

SB 80

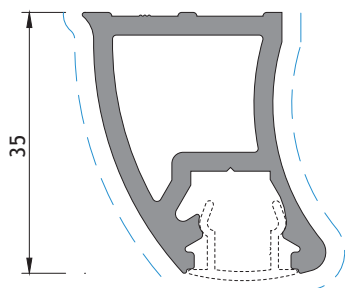

TL 25

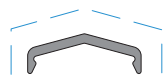

TL 91

PERFIL ACETINADO NATURAL ou PRETO  
APLICAR EM PERFIS LACADOS

PROFILE NATURAL SATIN FINISH or BLACK  
TO APPLY ON LACQUERED PROFILES

PROFIL SATINÉ NATUREL ou NOIR  
S'APPLIQUE AUX PROFILS LAQUÉS



AT 30



TL 26



SA 33

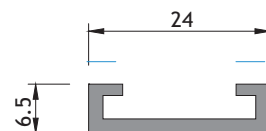

FC 20

**PERFIS EM PVC**

PVC PROFILES

PROFILES EN PVC

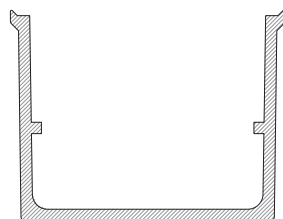

TL 96



## **Acessórios**

Accessories

Accessoires





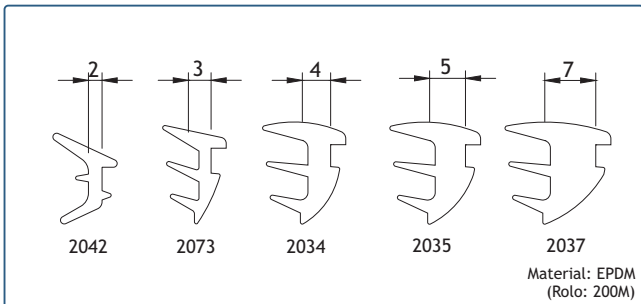

- |        |                     |        |                     |
|--------|---------------------|--------|---------------------|
| 208191 | JUNTA DE CUNHA 2042 | 208196 | JUNTA DE CUNHA 2035 |
| 208195 | JUNTA DE CUNHA 2034 | 208904 | JUNTA DE CUNHA 2037 |
|        |                     | 208199 | JUNTA DE CUNHA 2073 |

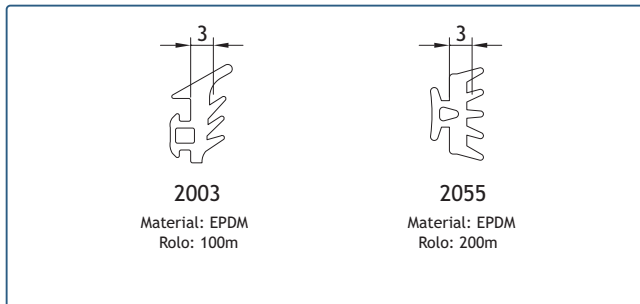

- |        |  |                                |
|--------|--|--------------------------------|
| 208350 |  | JUNTA DE VEDAÇÃO EXTERIOR 2003 |
| 208289 |  | JUNTA DE BATENTE 2055          |

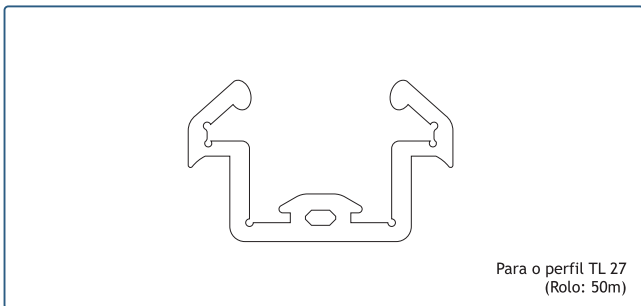

- 203316 JUNTA PARA 4 FOLHAS VR 2139

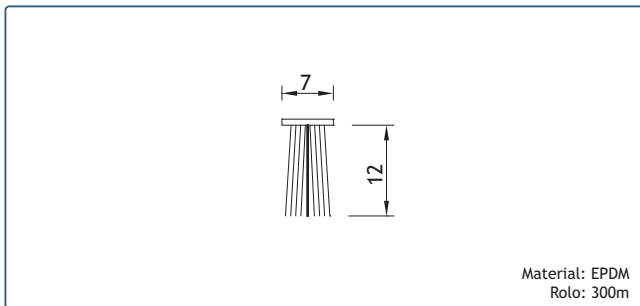

- 208593 VEDANTE PELÚCIA 7x12 S-FIN

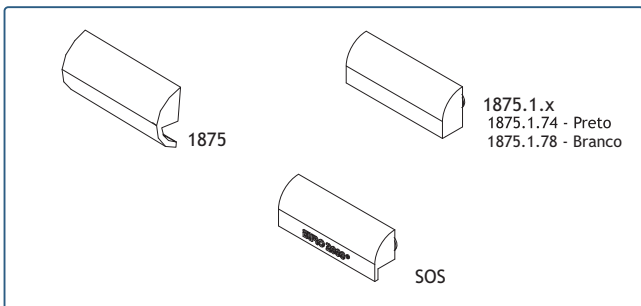

- |        |                        |        |                       |
|--------|------------------------|--------|-----------------------|
| 210154 | GOTEIRA 1875 Br/Pr     | 210142 | GOT C/ VÁLV 1875.1.74 |
| 210280 | GOT. SOS C/VÁLV. Br/Pr | 210144 | GOT C/ VÁLV 1875.1.78 |

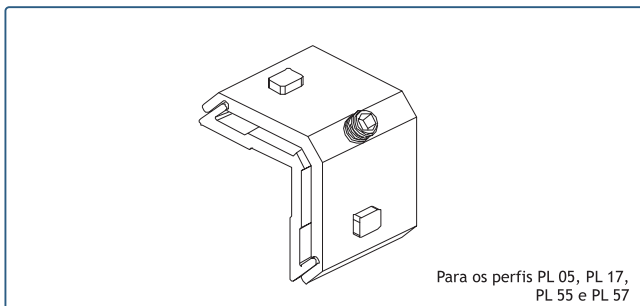

- 204392 ESQUADRO PL E. PEQUENO

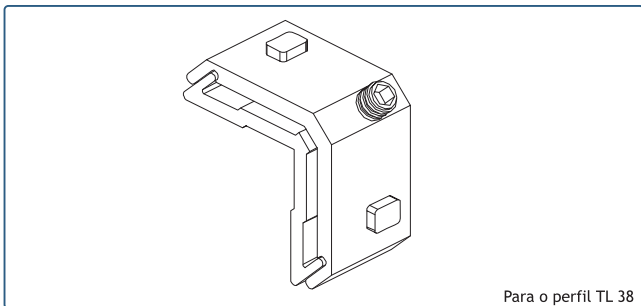

- 204728 ESQUADRO AT E. PEQUENO

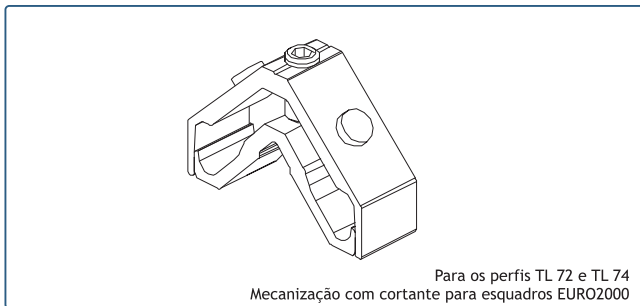

- 204745 ESQUADRO TL GRANDE

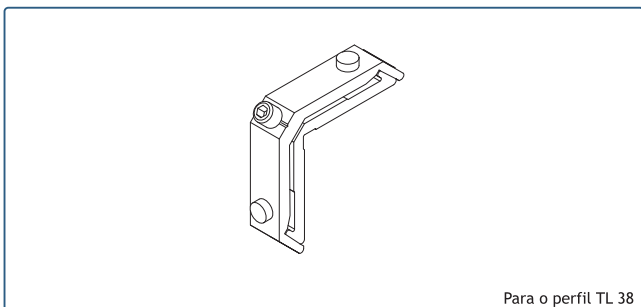

- 204457 ESQUADRO TL 38 E. PEQUENO

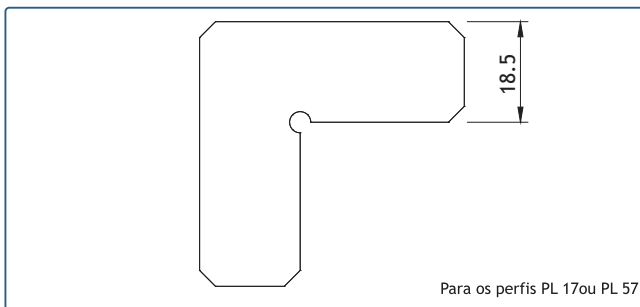

- 213242 CANTO CR 2002

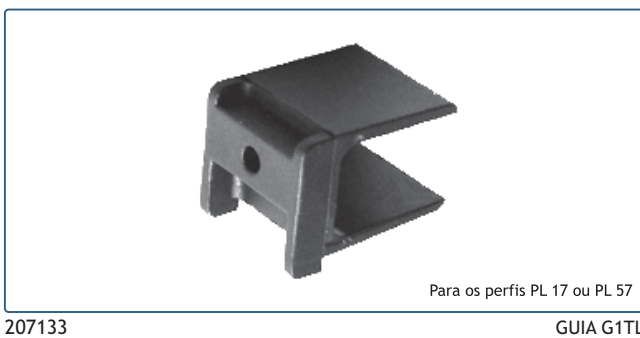
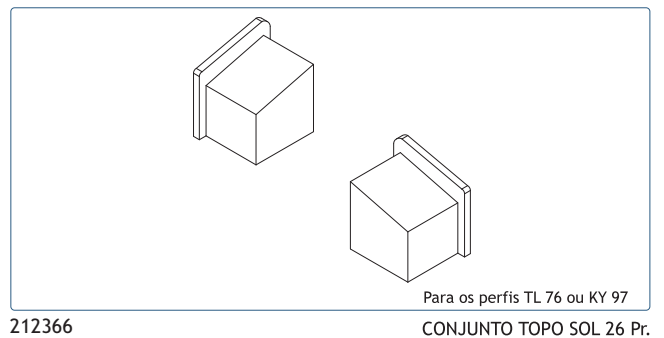
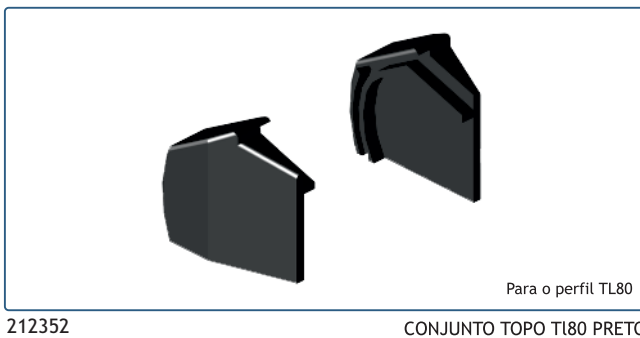
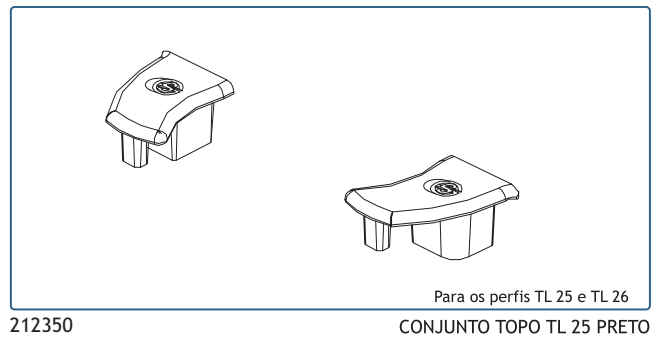
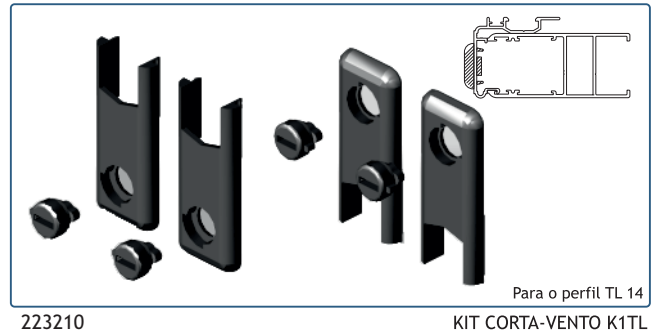
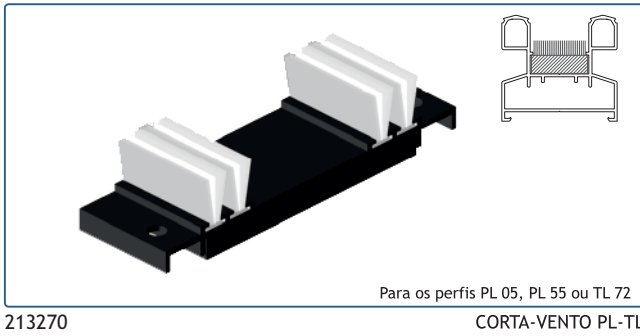
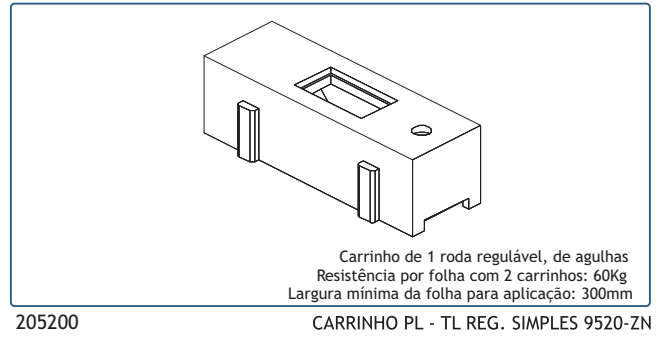
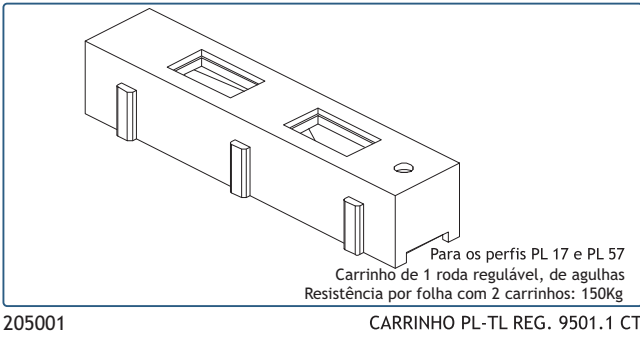



201478 FECHO LATERAL MANUAL 2070 (Lac.Br./Pr.)



201470 FECHO LATERAL AUTOMÁTICO 2071 (Lac.Br./Pr.)



201375 FECHO COM FECHADURA 2073 (Lac.Br./Pr.)



201475 FECHO LATERAL JM 247i (Lac.Br./Lac. Pr./Acetinado Natural)

Fecho alternativo sem fixação à vista.  
Aplicar com o Gancho PL/TL + o Contra Fecho 2070.861



200026 ASA PARA FECHO LATERAL 2080 (Br./Pr.)

Asa para os fechos 2070, 2071, 2073



204712 GANCHO FECHO 2070/833

Para aplicar com os fechos laterais 2070/2071/2073



000000 GANCHO-FECHO 2050/711

Aplicar com o fecho 2060

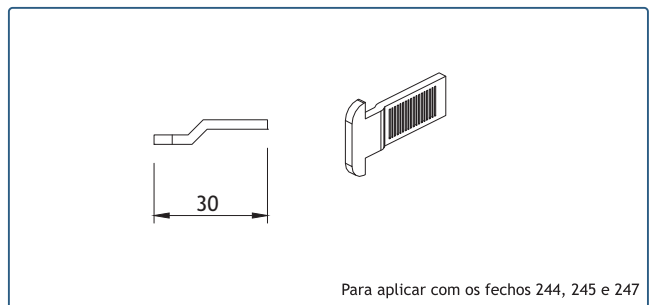

204723 GANCHO PL / TL

Para aplicar com os fechos 244, 245 e 247

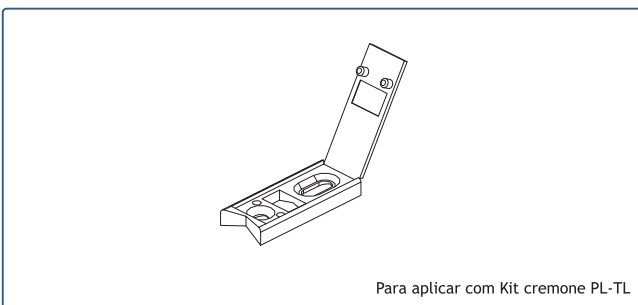
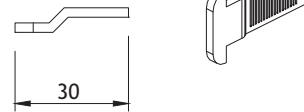

202093 CONTRA-FECHO NYLON 386 PRETO

Para aplicar com Kit cremone PL-TL



202083 CONTRA FECHO 2070.861

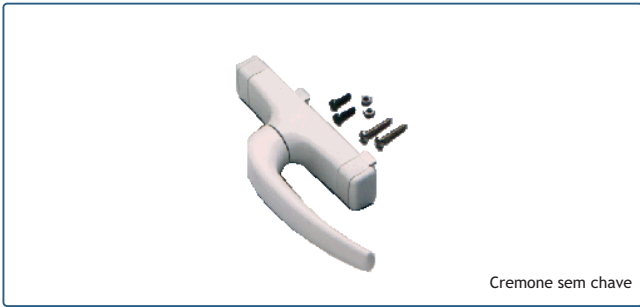

Cremona sem chave

200330 CREMONE MANON 876 (Lac. Pr./Lac. Br.)



Cremona com chave

200290 CREMONE MANON EXT. 876.751 (Lac. Pr./Lac. Br.)

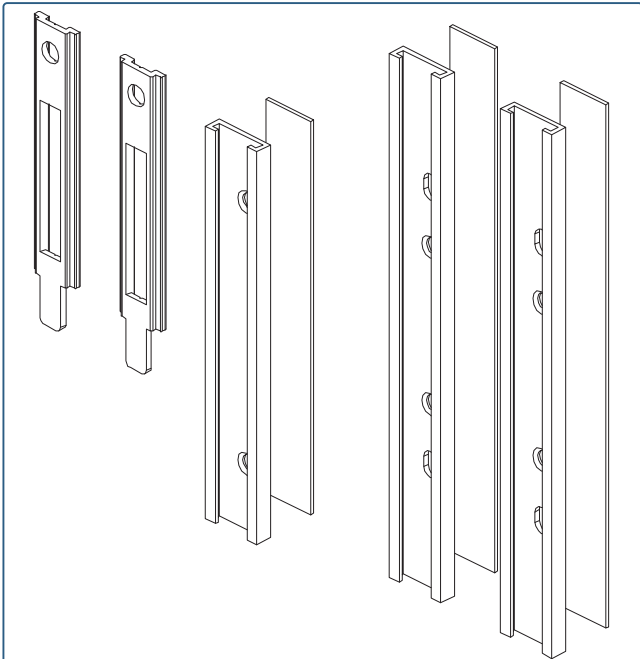

Kit para aplicar com Cremona 876 ou 876.751

223800 KIT PARA CREMONE PL-TL



Peça para ligar Vareta SA 33 com Kit para Cremona PL-TL

215114 PEÇA CREMONE VARETA 1481 OXID.

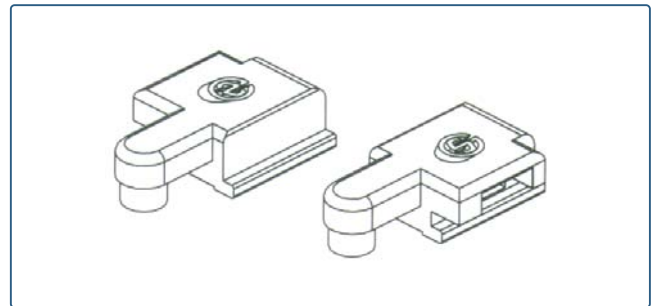

212054 CONJUNTO CREMONE VARETA 1481 NYLON PRETO

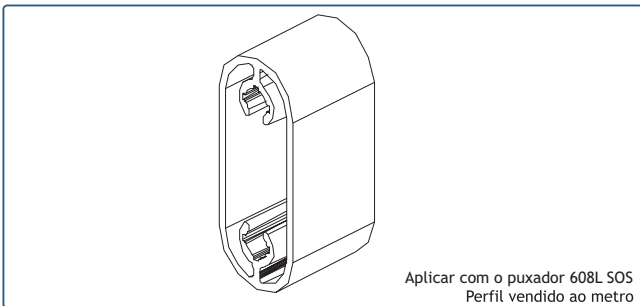

Aplicar com o puxador 608L SOS  
Perfil vendido ao metro

CALÇO X-00 (30mm)

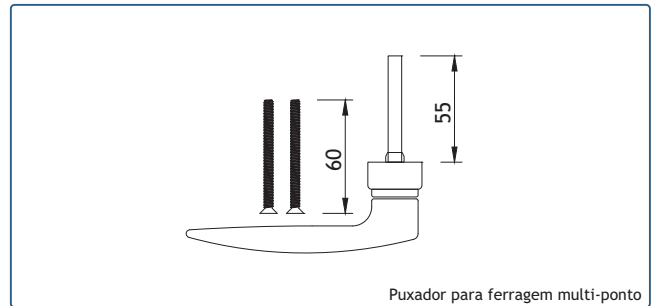

Puxador para ferragem multi-ponto

200025 PUXADOR SIMPLES 608L SOS

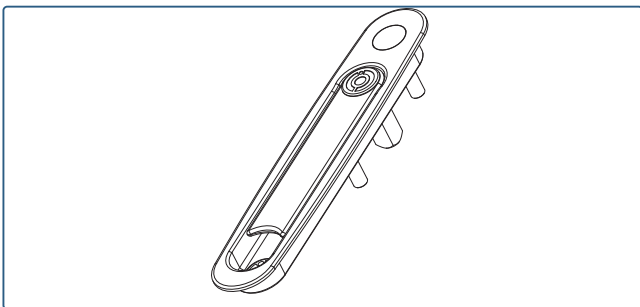

201467 FECHO DE EMBUTIR PARA MULTIPONTO CB-400



Peça para ligar Vareta SA 33 com Kit para Cremona PL-TL

215112 LIGAÇÃO VARETA/TERMINAL PB



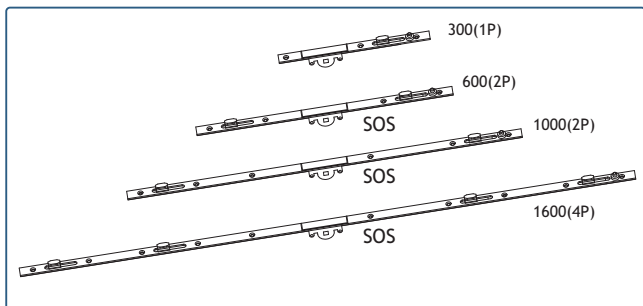

211205 FERRAGEM MULTI-PONTO 300 (1P)  
 211191 FERRAGEM MULTI-PONTO SOS 600 (2P)  
 211192 FERRAGEM MULTI-PONTO SOS 1000 (2P)  
 211193 FERRAGEM MULTI-PONTO SOS 1600 (4P)

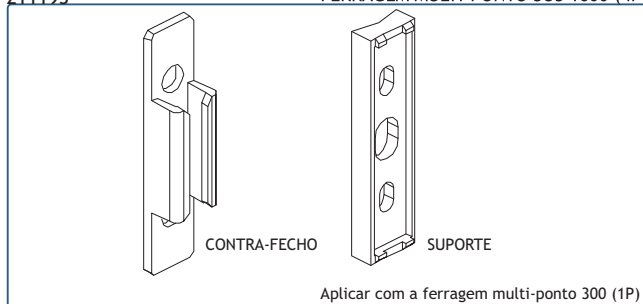

Aplicar com a ferragem multi-ponto 300 (1P)

202098 CONTRA-FECHO MULTI-PONTO 300 (1P)  
 230303 SUPORTE PARA CONTRA-FECHO MULTI-PONTO 300(1P)



Puxador para ferragens multi-ponto

200029 PUXADOR JANELA 20040 INOX

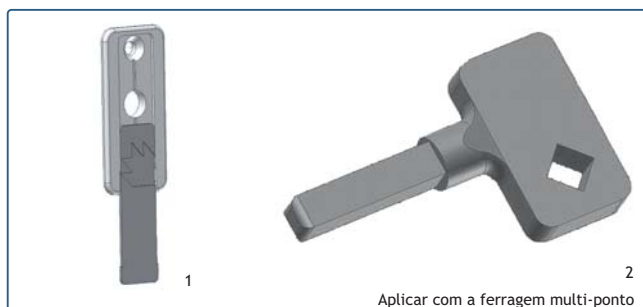

Aplicar com a ferragem multi-ponto

214010 1 - BASE PARA FERRAGEM MULTI-PONTO  
 469002 2 - CHAVE PARA FERRAGEM MULTI-PONTO

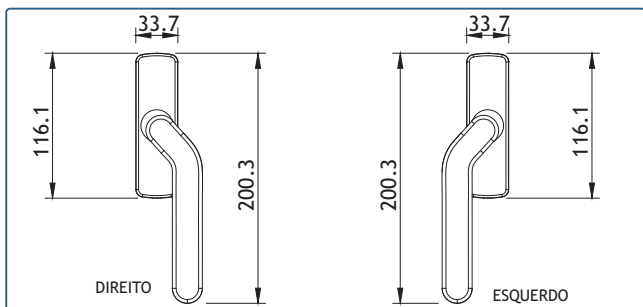

200939 CREMONE MULTI-PONTO DESVIADO - ESQUERDO  
 200959 CREMONE MULTI-PONTO DESVIADO - DIREITO



Aplicar com o contra-fecho multi-ponto 300 (1P)

215060 PEÇA ANTI-LEVANTAMENTO MULTI-PONTO 300(1P)

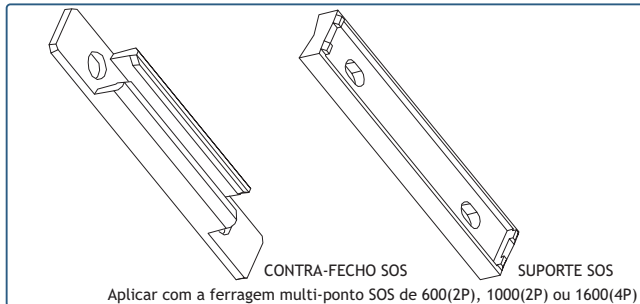

Aplicar com a ferragem multi-ponto SOS de 600(2P), 1000(2P) ou 1600(4P)

202094 CONTRA-FECHO MULTI-PONTO SOS  
 230307 SUPORTE PARA CONTRA-FECHO MULTI-PONTO SOS

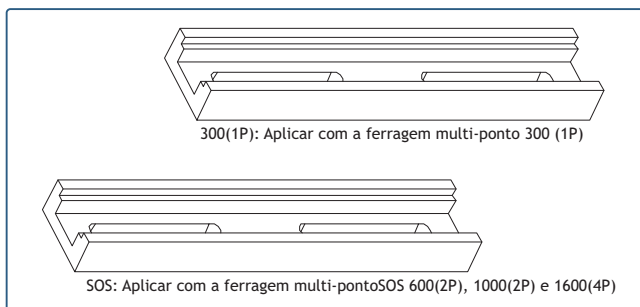

300(1P): Aplicar com a ferragem multi-ponto 300 (1P)

SOS: Aplicar com a ferragem multi-ponto SOS 600(2P), 1000(2P) e 1600(4P)

230304 SUPORTE PARA FERRAGEM MULTI-PONTO 300 (1P)  
 230306 SUPORTE PARA FERRAGEM MULTI-PONTO SOS

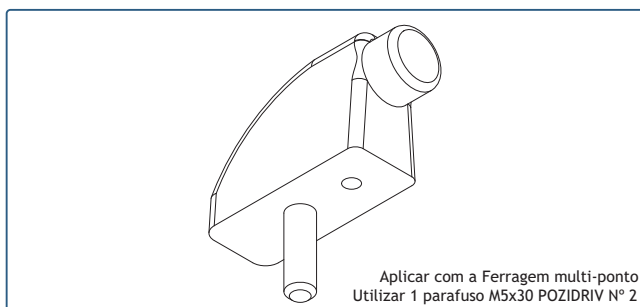

Aplicar com a Ferragem multi-ponto Utilizar 1 parafuso M5x30 POZIDRIV Nº 2

214164 BATENTE TOPEHSN

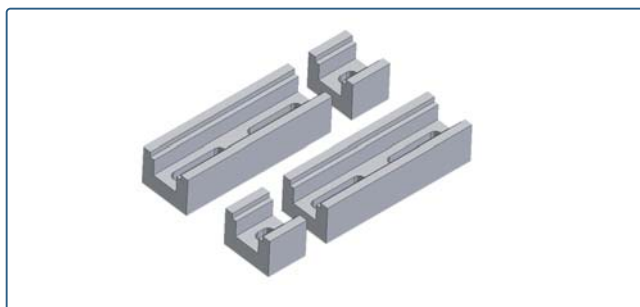

212701 CONJUNTO DE CALÇOS PARA FERRAGEM SR-3000



Ferragem com 1 ponto de fecho  
Aplicar com o contra-fecho 2070.862

Utilizar com os puxadores:  
- Simples 608L SOS;  
- 20040 (int.);  
- Cremone multi-ponto descentrado.

211001

FERRAGEM 1 PONTO SR-3100 INOX

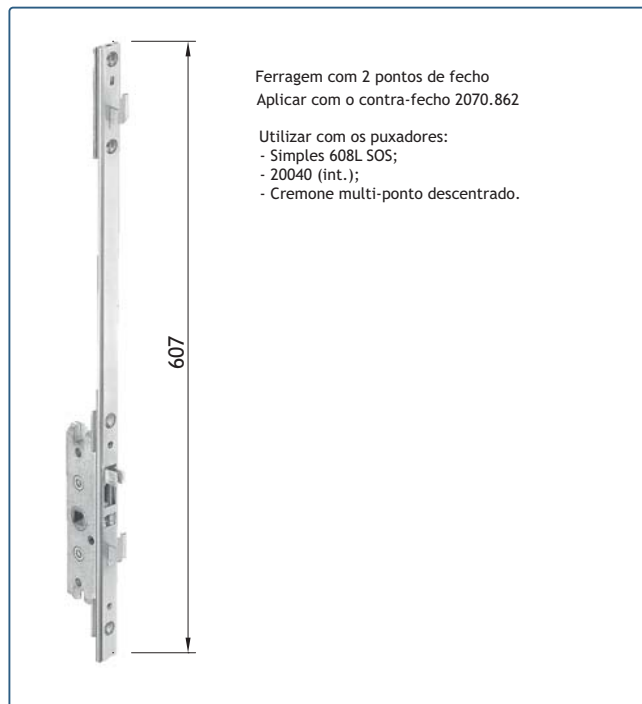

Ferragem com 2 pontos de fecho  
Aplicar com o contra-fecho 2070.862

Utilizar com os puxadores:  
- Simples 608L SOS;  
- 20040 (int.);  
- Cremone multi-ponto descentrado.

211002

FERRAGEM 2 PONTOS SR-3200 INOX



Ferragem com 3 pontos de fecho  
Aplicar com o contra-fecho 2070.862

Utilizar com os puxadores:  
- Simples 608L SOS;  
- 20040 (int.);  
- Cremone multi-ponto descentrado.

211003

FERRAGEM 3 PONTOS SR-3300 INOX

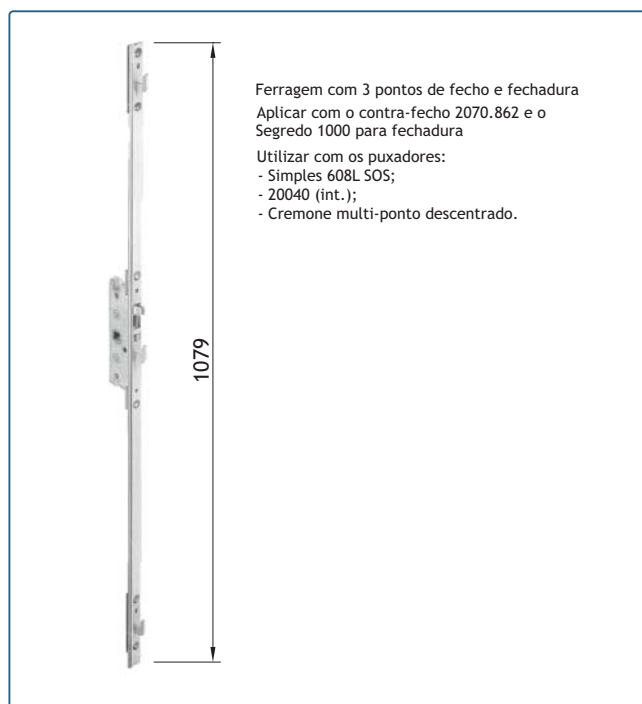

Ferragem com 3 pontos de fecho e fechadura  
Aplicar com o contra-fecho 2070.862 e o Segredo 1000 para fechadura

Utilizar com os puxadores:  
- Simples 608L SOS;  
- 20040 (int.);  
- Cremone multi-ponto descentrado.

211551

FERRAGEM 3 PONTOS COM CHAVE SR-3300i INOX

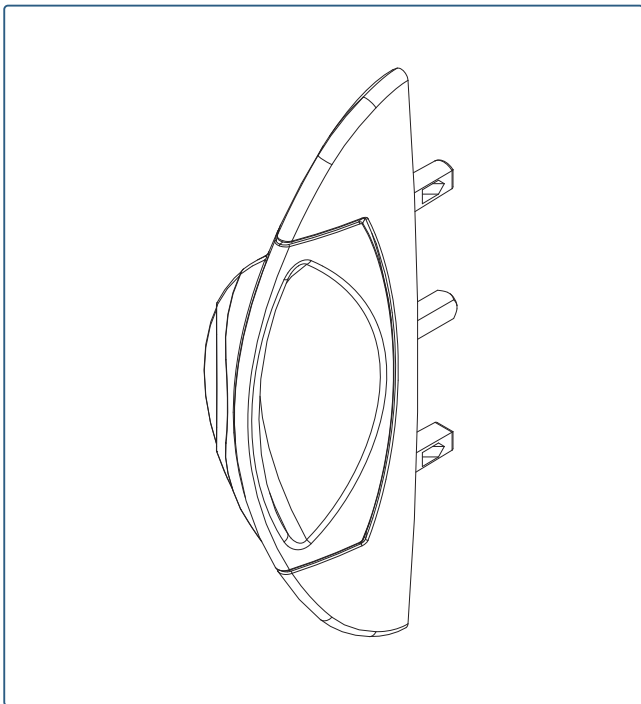

200961 PUXADOR INTERIOR NEPTUNE 9921  
200966 PUXADOR EXTERIOR NEPTUNE 9941

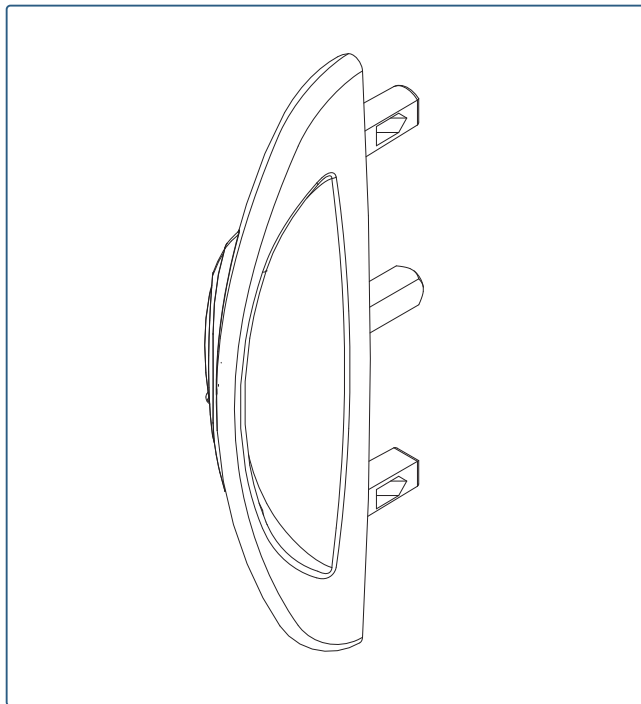

200986 PUXADOR INTERIOR CALIPSO 9920  
200968 PUXADOR EXTERIOR CALIPSO 9940

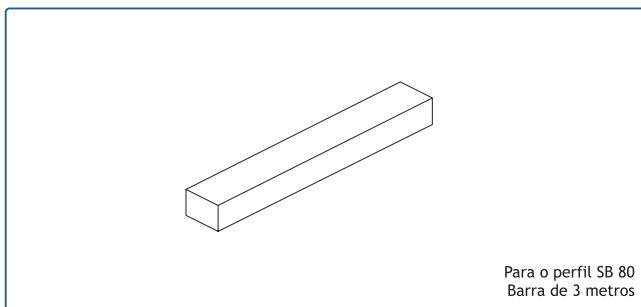

Para o perfil SB 80  
Barra de 3 metros

219133 DESLIZADOR CALHA 1201

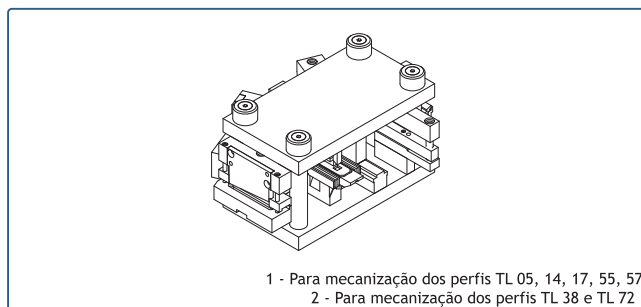

1 - Para mecanização dos perfis TL 05, 14, 17, 55, 57  
2 - Para mecanização dos perfis TL 38 e TL 72

408027 1 - CORTANTE SÉRIES TL-PL  
408033 2 - CORTANTE SÉRIES SA2000+AT2100



Limpeza de alumínio lacado ou anodizado  
Para preparação das zonas a serem unidas e limpeza final

208704 PRODUTO DE LIMPEZA DE ALUMÍNIO (1L) Transparente



Junta de vedação elástica, resistente aos UV  
Impede a corrosão de penetrar pelas zonas cortadas

208019 SELA JUNTAS 150gr. (Cinza)





## **Pormenores de montagem**

Assembly details  
Détails d'assemblage





### JANELA DE CORRER DE 2 FOLHAS - LINHA DECORATIVA

2 LEAVES SLIDING WINDOW - DECORATIVE LINE

FENÊTRE COULISSANTE 2 VANTAUX - LIGNE DÉCORATIVE

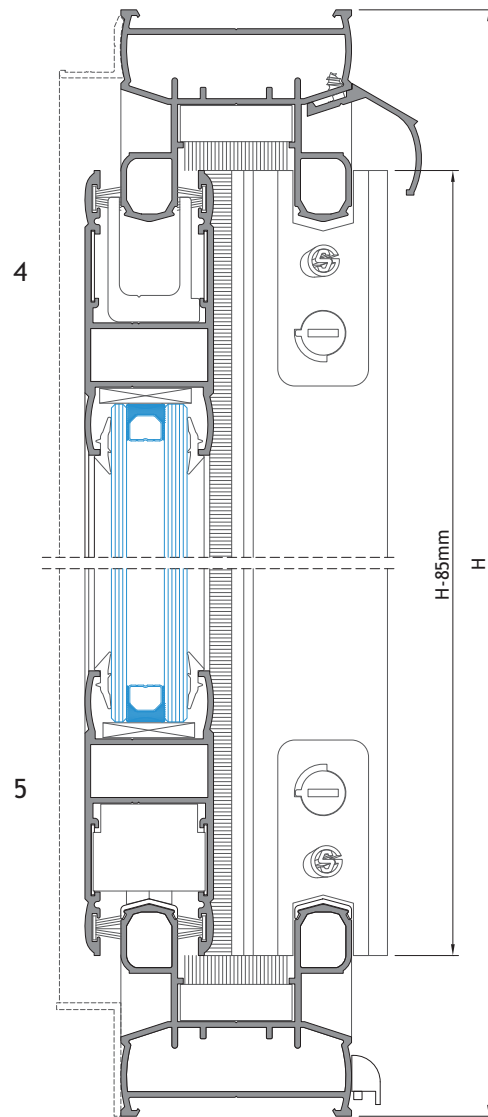
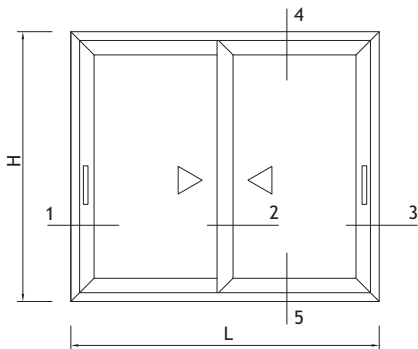

| PERFIS<br>PROFILES   PROFILS         |   |   |                                    |                       |
|--------------------------------------|---|---|------------------------------------|-----------------------|
| REFERÊNCIA<br>REFERENCE<br>RÉFÉRENCE | CORTE HORIZONTAL<br>HORIZONTAL DETAIL<br>DÉTAIL HORIZONTAL            | CORTE VERTICAL<br>VERTICAL DETAIL<br>DÉTAIL VERTICALE | QUANTIDADE<br>QUANTITY<br>QUANTITÉ | CORTE<br>CUT<br>COUPÉ |
| PL 05                                | L   | H   | 2+2                                |                       |
| PL 17                                | (L-17)/2  | H-85  | 4+4                                |                       |
| PL 14                                | -   | H-85  | 2                                  |                       |
| TL 80                                | L-54  | -   | 1                                  |                       |
| TL 91                                | L-104.5   | -   | 2                                  |                       |
| AT 30                                | -   | H-85  | 2                                  |                       |
| TL 81                                | APLICAÇÃO FACULTATIVA<br>OPTIONAL APPLICATION   APPLICATION OPTIONNEL |   |                                    |                       |
| KL 84                                |   |   |                                    |                       |

| ACESSÓRIOS<br>ACCESSORIES   ACCESSOIRES |   |                                   |
|---|---|-----------------------------------|
| CÓDIGO<br>CODE                          | DESIGNAÇÃO<br>DESIGNATION   DÉSIGNATION                             | QUANTIDADE<br>QUANTITY   QUANTITÉ |
| 210280                                  | GOTEIRA SOS COM VÁLVULA   DRIP   GOUTIÈRE                           | 2                                 |
| 205001                                  | CARRINHO PL-TL REG. C/ROL. AG.   ROLLING BEARING   ROULEAU          | 4                                 |
| 223210                                  | KIT CORTA-VENTO K1TL   WIND-CUT KIT   KIT BRISE-VENT                | 1                                 |
| 213270                                  | CORTA-VENTO PL-TL   WIND-CUT   BRISE-VENT                           | 2                                 |
| 212380                                  | CONJ GUIAS C/AMORT. K5 PL-TL   GUIDES KIT   KIT DE GUIDES           | 1                                 |
| 202083                                  | CONTRA-FECHO 2070.861   COUNTER-LOCK BRACKET   C.-FERMETURE SUPPORT | 2                                 |
| 201470                                  | FECHO LAT. AUTOM. (P/B) 2071   LATERAL LOCK   FERMETURE LATÉRAL     | 2                                 |
| 204712                                  | GANCHO-FECHO 2070.833   LOCK-HOOK   CROCHETS                        | 2                                 |
| 204392                                  | ESQUADRO PL ESP. PEQ.   BLOCKING BRACKET   ÉQUERRE                  | 12                                |
| 213242                                  | CANTO CR2002   ANGLE   COIN   | 16                                |
| 207133                                  | GUIA G1TL   GUIDE   GUIDE   | 4                                 |
| 213252                                  | CONJUNTO TOPO TL 80   END/CAP KIT   KIT DE EMBOUTS                  | 1                                 |

| VEDANTES<br>SEALANTS   JOINTS |   |                                   |
|-------------------------------|---|-----------------------------------|
| CÓDIGO<br>CODE                | DESIGNAÇÃO<br>DESIGNATION   DÉSIGNATION                 | QUANTIDADE<br>QUANTITY   QUANTITÉ |
| VARIÁVEL<br>VARIABLE          | JUNTA INTERIOR   GLAZING WEDGE GASKET   JOINT INTÉRIEUR | 4L+8H                             |
| 208593                        | PELÚCIA 7x12 S-FIN   PLUSH   JOINT BROUSSE              | 4L+6H                             |

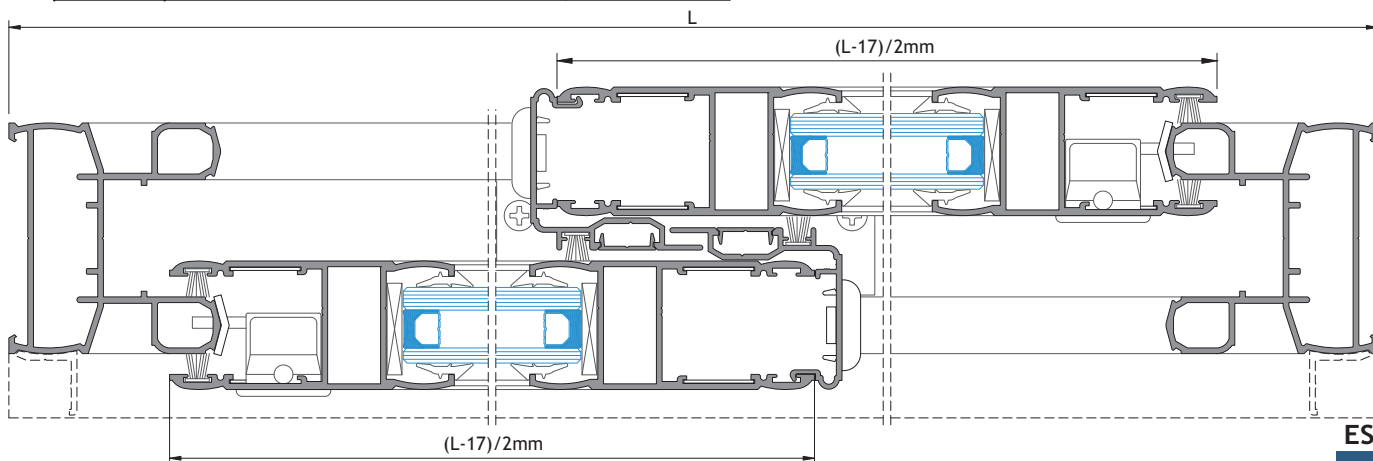

ESC: 1/2



1

2

3

**JANELA DE CORRER DE 3 FOLHAS - COM PERFIL BI-RAIL - LINHA RETA**

3 LEAVES SLIDING WINDOW - WITH 2-RAIL PROFILE - STRAIGHT LINE

FENÊTRE COULISSANTE 3 VANTAUX - SUR PROFILE 2-RAIL - LIGNE DROITE

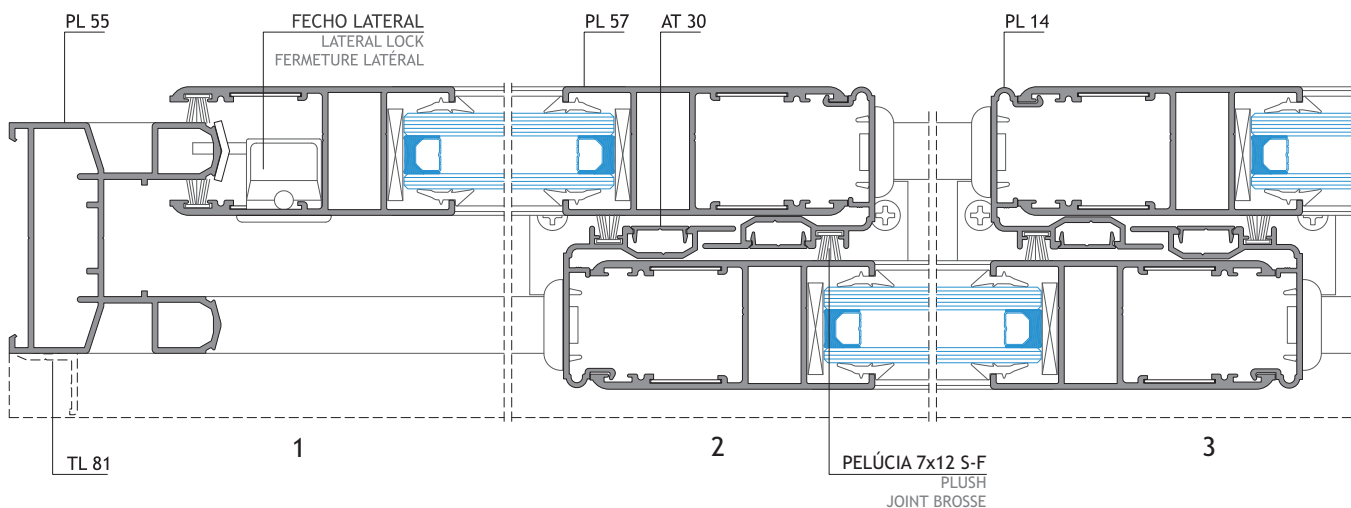
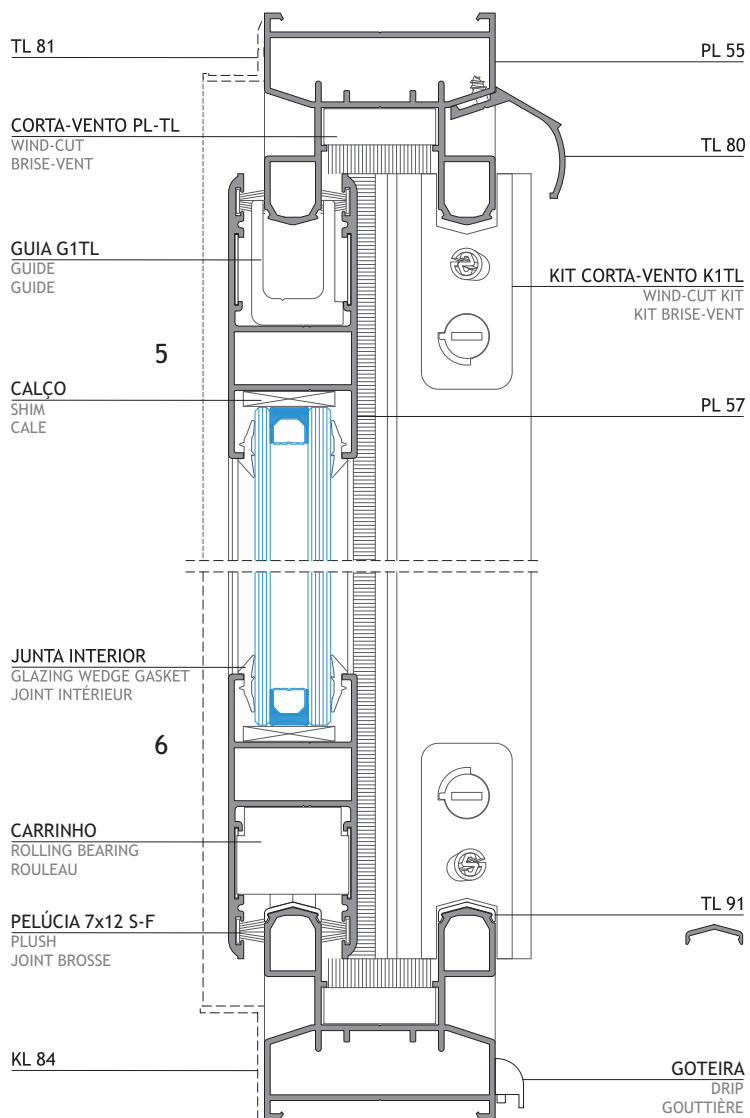
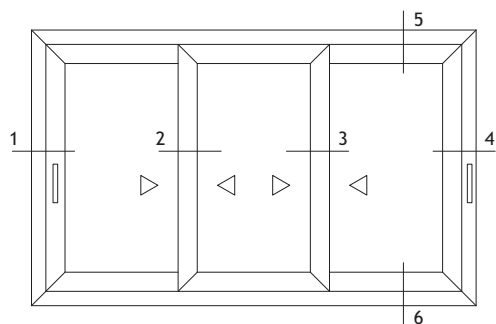

ESC: 1/2





**JANELA DE CORRER DE 4 FOLHAS - COM PERFIL BI-RAIL - LINHA DECORATIVA**

4 LEAVES SLIDING WINDOW - WITH 2-RAIL PROFILE - DECORATIVE LINE

FENÊTRE COULISSANTE 4 VANTAOX - SUR PROFILE 2-RAIL - LIGNE DÉCORATIVE

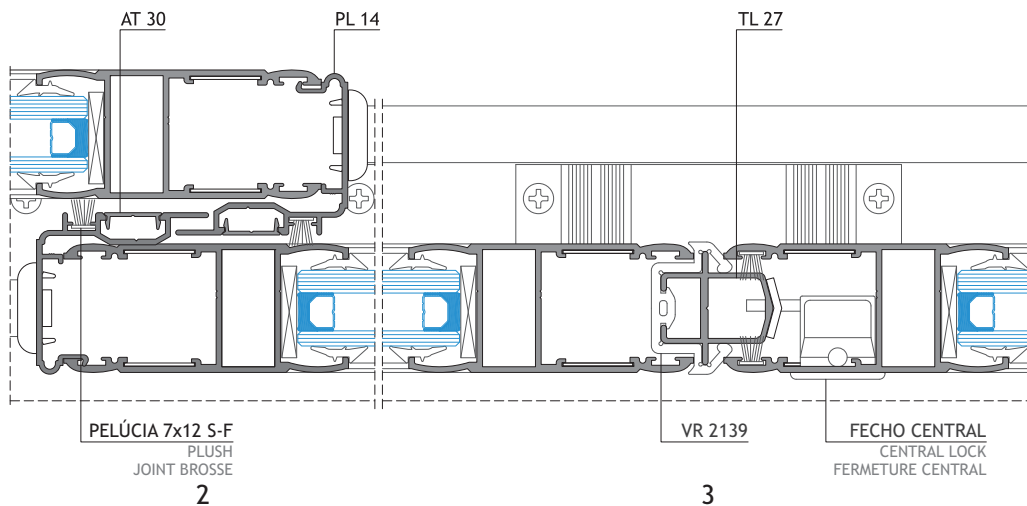
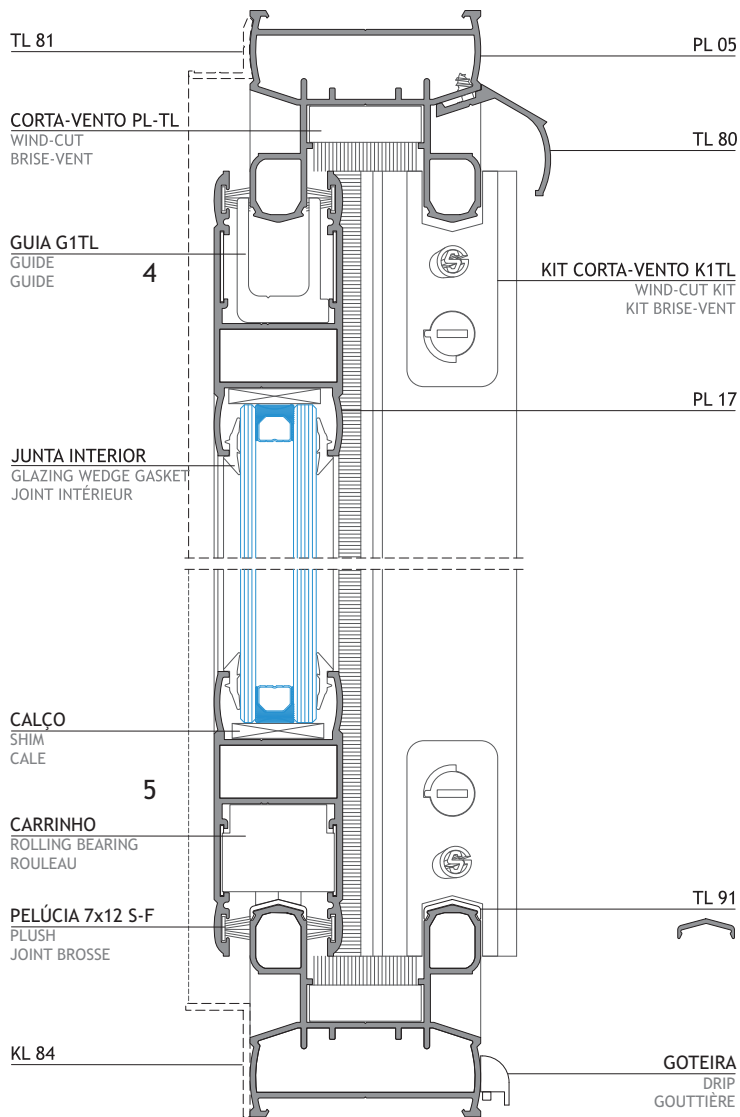
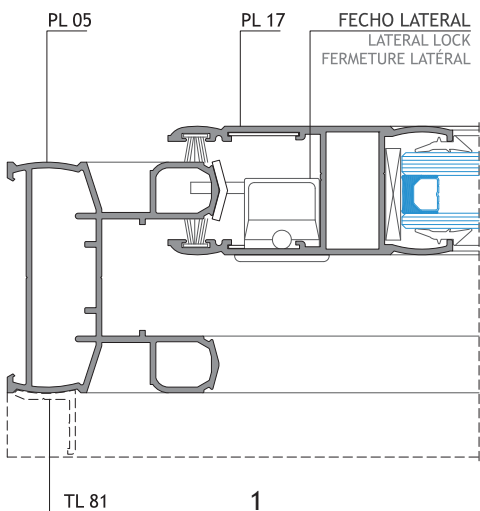
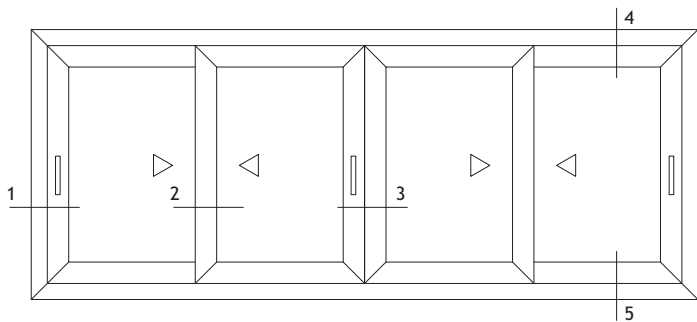



**PORTA DE CORRER DE 2 FOLHAS - COM PERFIL DE REFORÇO TL 25**

4 LEAVES SLIDING DOOR - WITH WITH REINFORCEMENT PROFILE TL 25

PORTE COULISSANTE 2 VANTAOX - AVEC PROFIL DE RENFORCEMENT TL 25

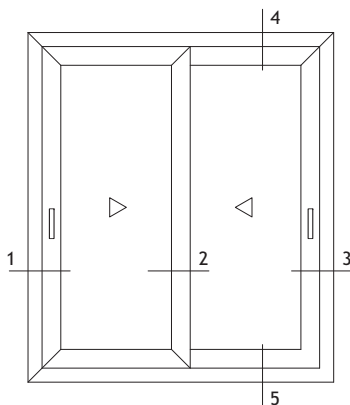

CONSULTAR DEPARTAMENTO TÉCNICO PARA VERIFICAÇÃO DA RESISTÊNCIA PARA DEFINIR A QUANTIDADE DE PERFIS DE REFORÇO A UTILIZAR.

TO DEFINE THE REINFORCEMENT PROFILES QUANTITIES, CONTACT THE TECHNICAL DEPARTMENT FOR RESISTANCE VERIFICATION.

CONSULTER LE DÉPARTEMENT TECHNIQUE POUR FAIRE LA VERIFICATION DE LA RÉSISTANCE POUR DÉFINIR LA QUANTITÉ DE PROFILS DE RENFORCE À UTILISÉ

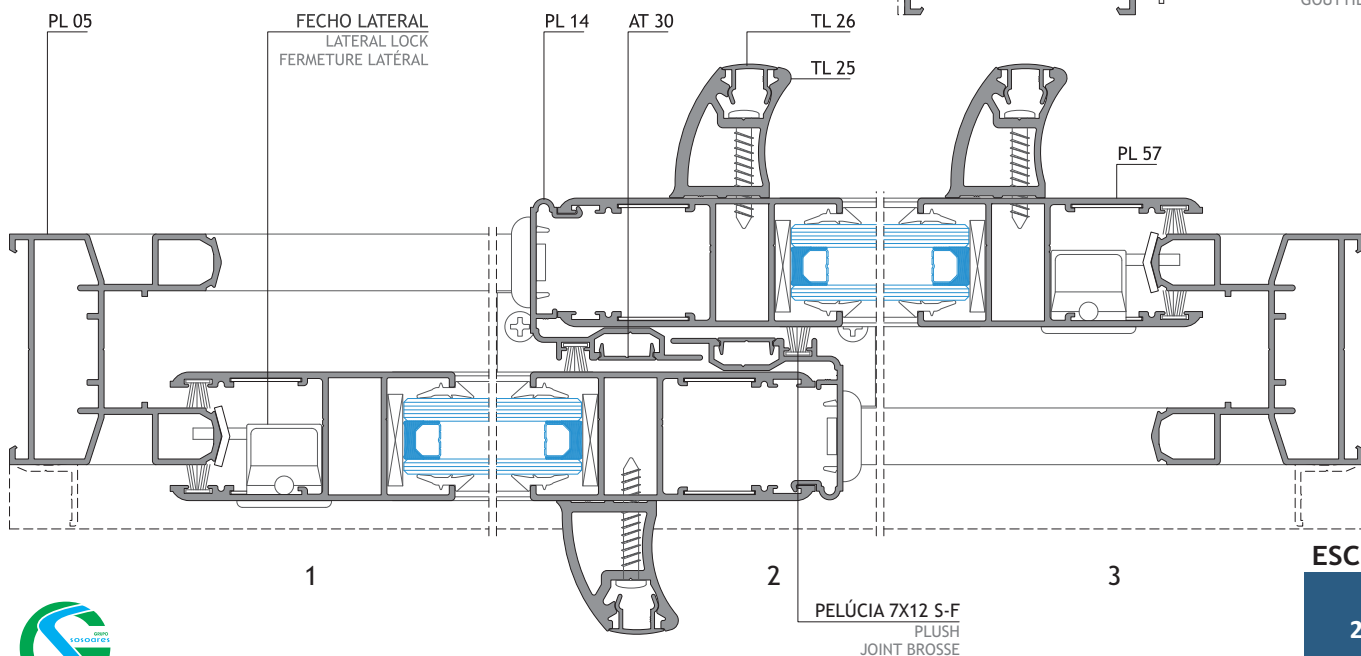
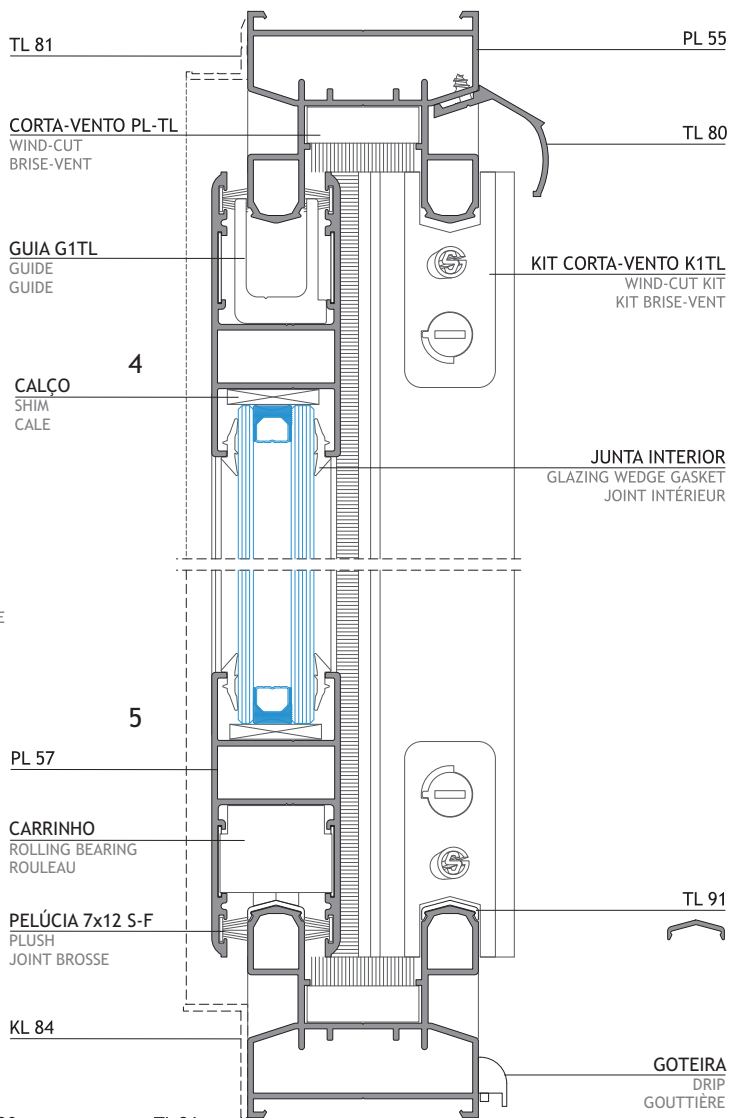

ESC: 1/2



**PORMENORES DE REMATE**

TRIM PROFILE DETAILS

DÉTAIL DE COUVRE-JOINT

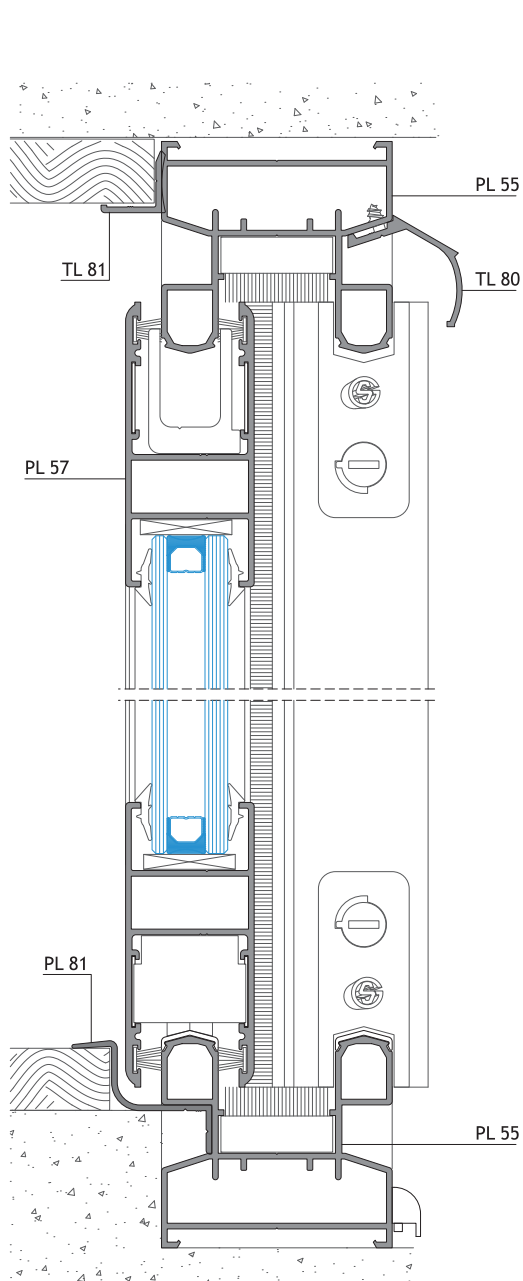

COM O PERFIL PL 81  
WITH PROFILE PL 81  
AVEC PROFIL PL 81

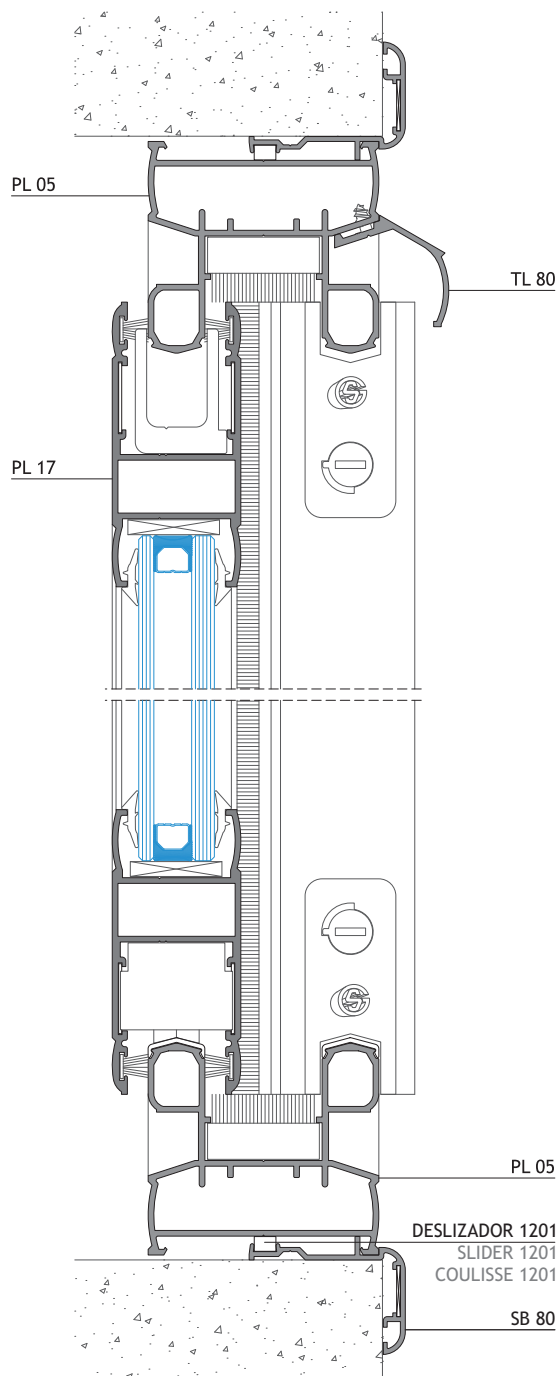

COM O PERFIL SB 80  
WITH PROFILE SB 80  
AVEC PROFIL SB 80

**PORMENORES DE LIGAÇÃO**

LINK DETAILS

DÉTAIL DE CONNEXION

**COM VÃO BASCULANTE SUPERIOR**  
 WITH UPPER HOPPER WINDOW  
 AVEC DESSUS À SOUFFLET

CONSULTAR CATÁLOGO DO SISTEMA SA  
 CONSULT SA SYSTEM CATALOGUE | CONSULTER LE CATALOGUE DU SYSTÈME SA

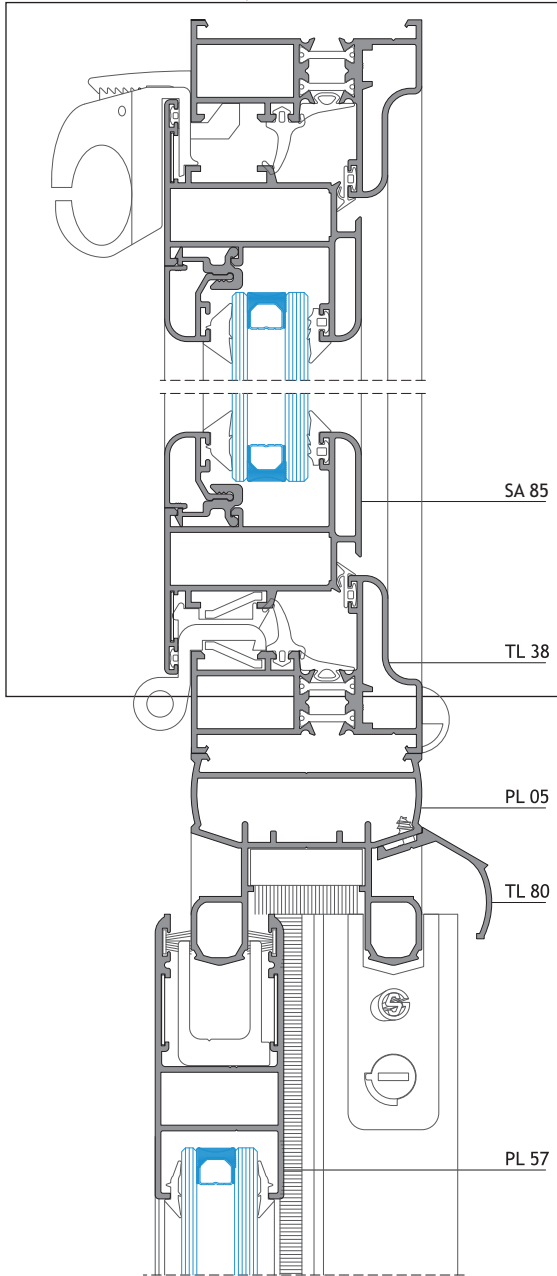

**COM FIXO SUPERIOR**  
 WITH UPPER FIXED FRAME  
 AVEC DESSUS FIXE

CONSULTAR CATÁLOGO DO SISTEMA SA  
 CONSULT SA SYSTEM CATALOGUE | CONSULTER LE CATALOGUE DU SYSTÈME SA

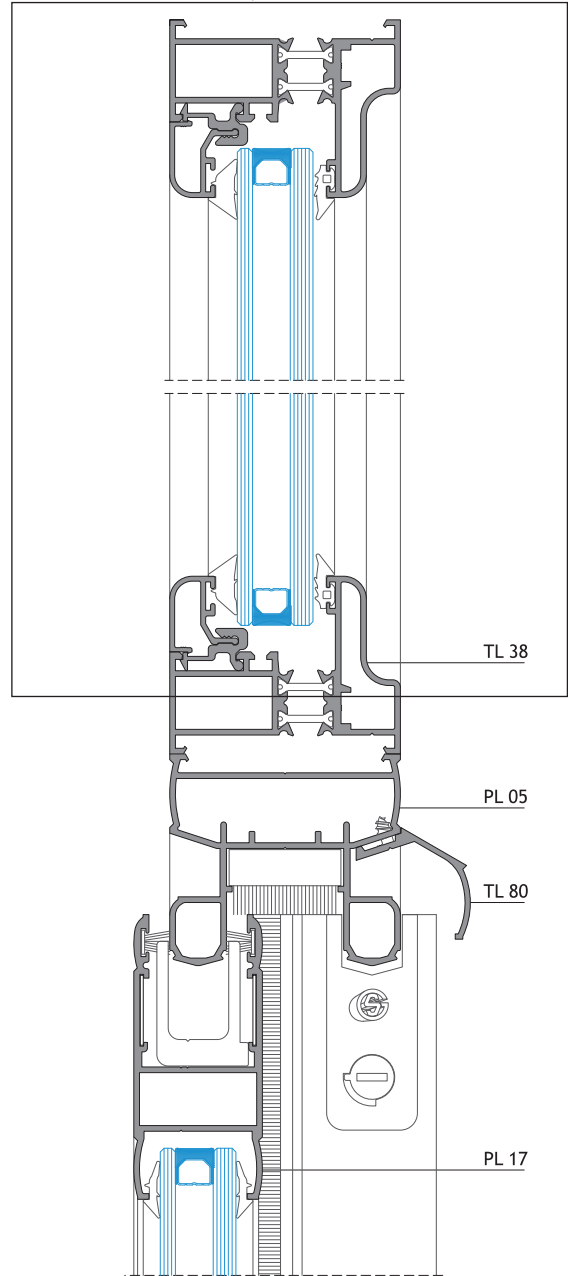







**SISTEMAS**  
**EURO 2000**®  
PERFIS DE ALUMÍNIO E VIDROS PARA ARQUITECTURA

### **ALFA SUL**

EN Lisboa-Sintra Km 14  
2725-397 Mem Martins  
T +351 219 265 090 | F +351 219 265 098  
E [alfa.sul@sosoares.pt](mailto:alfa.sul@sosoares.pt)

### **ALULIDER**

Pavilhão Industrial H - Plataforma 13D  
Zona Franca Industrial  
9200-047 Caniçal - Madeira  
T +351 291 960 494 | F +351 291 960 497  
E [alulider@sosoares.pt](mailto:alulider@sosoares.pt)

### **METALFER**

Travessa do Bolegão, 146  
Apartado 1  
3754-904 Fermentelos  
T +351 234 729 740 | F +351 234 729 741  
E [metalfer@sosoares.pt](mailto:metalfer@sosoares.pt)

### **PERFIS OEIRAS**

Rua da Colónia - Quinta da Cardoso  
Apartado 214 - Abrunheira  
2711-952 Sintra  
T +351 219 156 660 | F +351 219 156 661  
E [perfis.oeiras@sosoares.pt](mailto:perfis.oeiras@sosoares.pt)

### **PORTALEX**

Estrada de S. Marcos, 23  
2735-521 Cacém  
T +351 210 412 500 | F +351 210 412 507  
E [comercial@portalex.eu](mailto:comercial@portalex.eu)

### **SOSOARES**

Rua do Campo Alegre, 474  
4150-170 Porto  
T +351 226 096 709 | F +351 226 005 642  
E [comercial@sosoares.pt](mailto:comercial@sosoares.pt)



[www.sosoares.pt](http://www.sosoares.pt)



[www.portalex.eu](http://www.portalex.eu)