

## Sistema de portas de batente para uso intensivo

opening door system for intensive use

Système de portes à usage intensif





## Características do Sistema

### System features

### Caractéristiques du système



O sistema PS foi desenvolvido para a execução de portas de entrada de edifícios públicos ou privados com intensa utilização. Caracteriza-se como sendo um sistema com elevada resistência ao uso e ao vandalismo quando dotado de:

- Sistema Anti-arrombamento;
- Anti-entalamento de dedos;
- Barra anti-pânico.

PS system was developed for intensively used entrances to public or private buildings. It is a highly resistant system to usage and vandalism when provided with:

- Anti-break-in system;
- Anti-finger trap system;
- Anti-panic bar.

Le system PS à été développé pour la réalisation de portes d'entrée de bâtiments publiques ou privés, tous deux soumis à une utilisation intensive. Caractérisé par une grande résistance à l'usage et au vandalisme:

- Système anti-effraction;
- Système anti-pince doigt;
- Barre anti-panique.

<b>Apresentação:</b>	<b>Reta</b>	
Presentation	Straight	
Présentation	Droite	
<b>Dimensões:</b>	<b>Aro Fixo:</b>	<b>52mm</b>
Dimensions	Fixed frame:	52mm
Dimension	Cadre dormant:	52mm
	<b>Aro Móvel:</b>	<b>52mm</b>
	Mobile frame:	52mm
	Cadre ouvrant:	52mm
<b>Bites:</b>	<b>Retos</b>	
Glazing beads	Straight	
Parcloses	Droite	
<b>Enchimento:</b>	<b>De 4 a 39mm</b>	
Filling	From 4 to 39mm	
Remplissage	De 4 à 39mm	
<b>Cortes:</b>	<b>45°   90°</b>	
Cuts		
Coupes		
<b>Vedação:</b>	<b>Dupla, lateral em EPDM</b>	
Insulation	Double, side in EPDM	
Étanchéité	Double, latéral en EPDM	
<b>União:</b>	<b>Esquadros de bloqueio de 14mm, 32mm e 42mm</b>	
Joint	14mm, 32mm and 42mm blocking brackets	
Union	Équerres de verrouillage de 14mm, 32mm et 42mm	
<b>Peso máximo:</b>	<b>Abertura interior   exterior (1   2 folhas) - 180 Kg/folha   leaf   vantail</b>	
Maximum weight	Inward   outward opening (1   2 leaves)   Ouverture intérieur   extérieur (1   2 vantaux)	
Poids maximale	<b>Abertura Vai-vém (1   2 folhas) - 120 Kg/folha   leaf   vantail</b>	
	Swing opening (1   2 leaves)   Ouverture va-et-vien (1   2 vantaux)	
<b>Dimensão máxima:</b>	<b>Porta de 1 folha - 1,50mx3,00m (Largura x Altura)   (Width x Height)   (Largeur x Hauteur)</b>	
Maximum dimension	1 leaf door   porte de 1 vantail	
Dimension maximale	<b>Porta de 2 folhas - 3,00mx3,00m (Largura x Altura)   (Width x Height)   (Largeur x Hauteur)</b>	
	2 leaves door   Porte de 2 vantaux	
<b>Acabamentos:</b>	<b>Lacados   Anodizados</b>	
Finishes	Powder coating   Anodizing	
Finitions	Laqué   Anodisé	



Licença nº. 1406 - Metalfer  
Licença nº. 1411 - Alfa Sul



Licença nº. 809

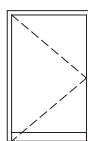

Abertura para interior 1 folha  
Inward opening 1 leaf  
Ouverture à l'intérieur 1 vantail

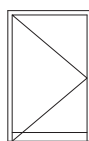

Abertura para exterior 1 folha  
Outward opening 1 leaf  
Ouverture à l'extérieur 1 vantail

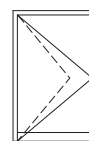

Abertura vai-vém 1 folha  
Swing opening 1 leaf  
Ouverture va-et-vien 1 vantail

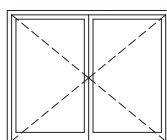

Abertura para interior 2 folhas  
Inward opening 2 leaves  
Ouverture à l'intérieur 2 vantaux

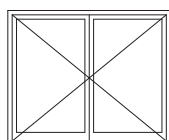

Abertura para exterior 2 folhas  
Outward opening 2 leaves  
Ouverture à l'extérieur 2 vantaux

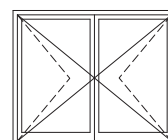

Abertura vai-vém 2 folhas  
Swing opening 2 leaves  
Ouverture va-et-vien 2 vantaux

## Desempenho do sistema

System performance

Performance du système

## Marcação CE

CE Marking

Marquage CE

NP EN 14351-1

Porta 2 folhas com 1.80x2.40m

Vidro : 6 + 14 + 8

2 leaves door 1.80 x 2.40m

Glass: 6 + 14 + 8

Porte 2 vantaux 1.80m x 2.40m

Verre: 6 + 14 + 8

## Permeabilidade ao AR

AIR Permeability

Perméabilité à l'AIR

**2**

## Estanquidade à ÁGUA

WATER Tightness

Étanchéité à l'EAU

**1A**

## Resistência ao VENTO

WIND Resistance

Résistance au VENT

**B4**

## Coef. Transm. TÉRMICA

THERMAL Transmittance

Coef. de Transmission THERMIQUE

**Uw = 2,96 W/m<sup>2</sup> K**Ug = 1,1W/m<sup>2</sup> K (Porta 2 folhas com 1,80x2,50m)Ug = 1,1W/m<sup>2</sup>K (2 leaves door with 1,80x2,50m)Ug = 1,1W/m<sup>2</sup>K (Porte de 2 vantaux avec 1,80x2,50m)

## Isolamento ACÚSTICO

ACOUSTIC Insulation

Isolation ACOUSTIQUE

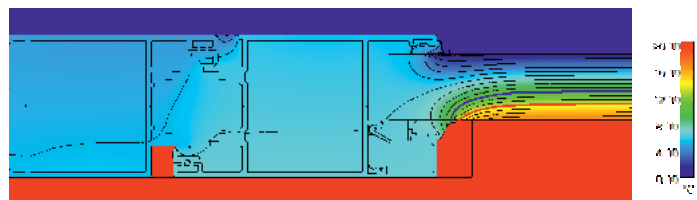
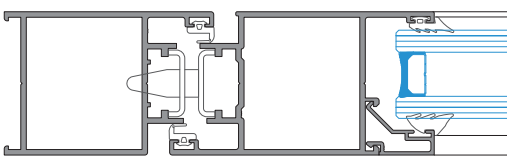
**Rw janela(dB)= 36dB**Rw vidro (IGU) = 36dB, área ≤ 2,70m<sup>2</sup>Rw glass (IGU) = 36dB, area ≤ 2,70m<sup>2</sup>Rw verre(IGU)=36dB, aire ≤ 2,70m<sup>2</sup>



5

**Listagem de perfis**

Profiles list

Liste des profils

13

**Acessórios**

Accessories

Accessoires

21

**Pormenores de montagem**

Assembly details

Détails d'assemblage





## Listagem de perfis

Profiles list

Liste des profils

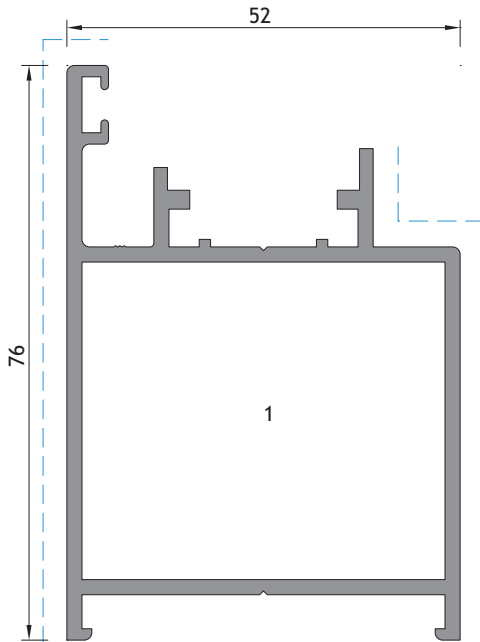

PS 07

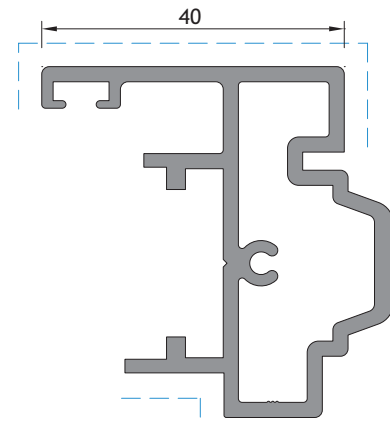

PS 06

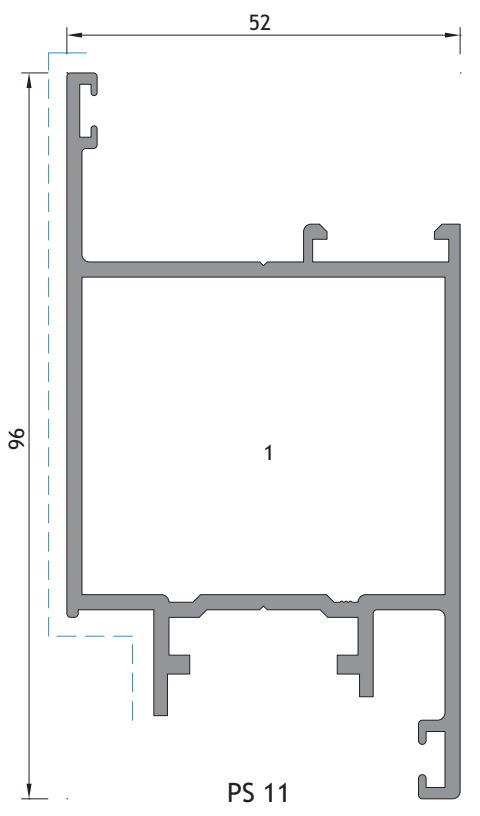

PS 11

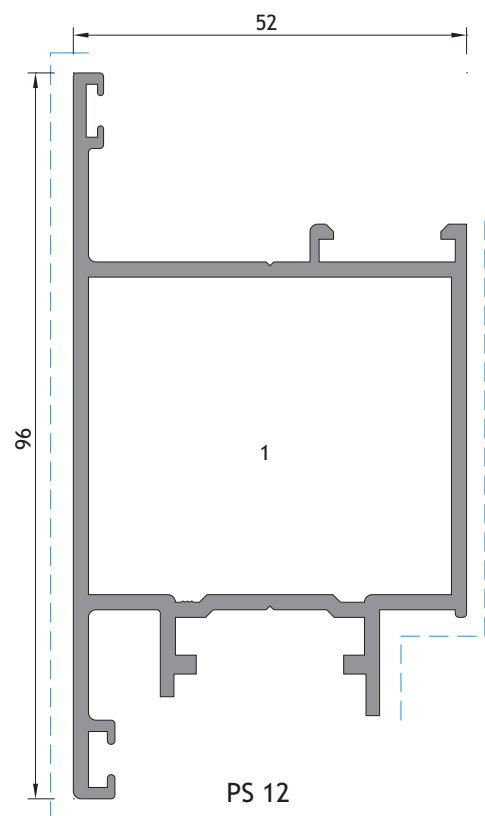

PS 12

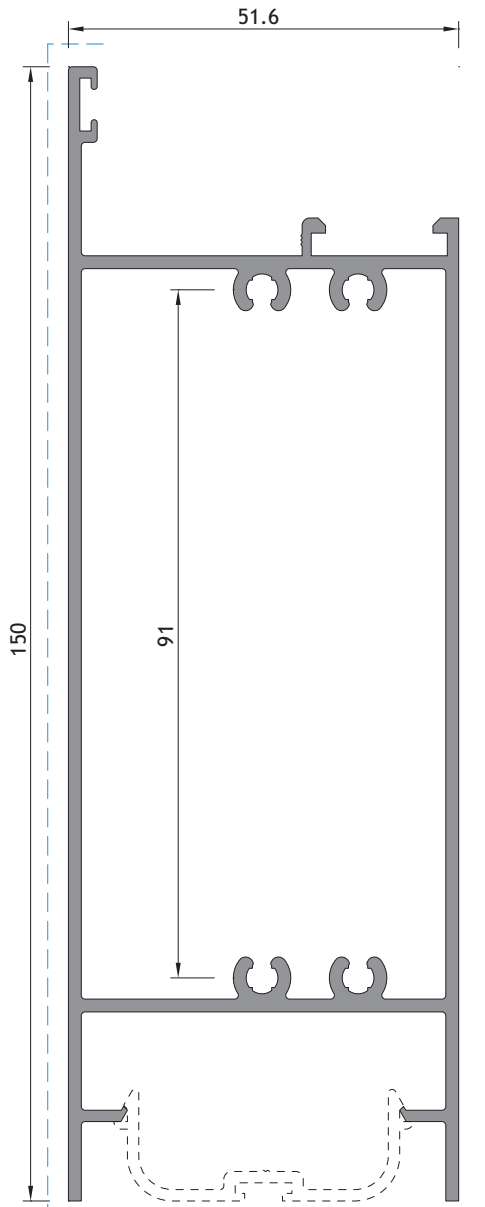

PS 52

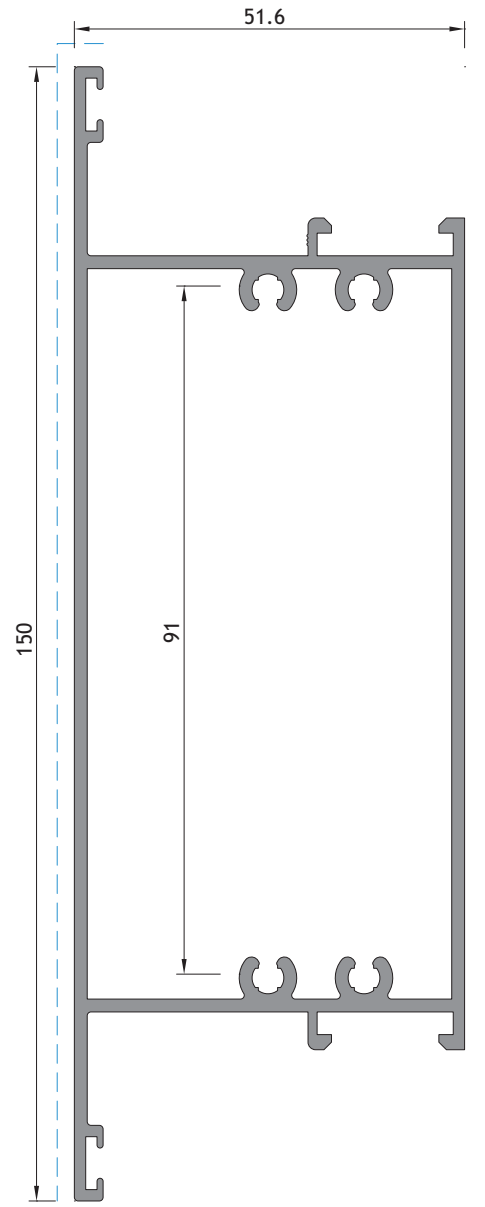

PS 14



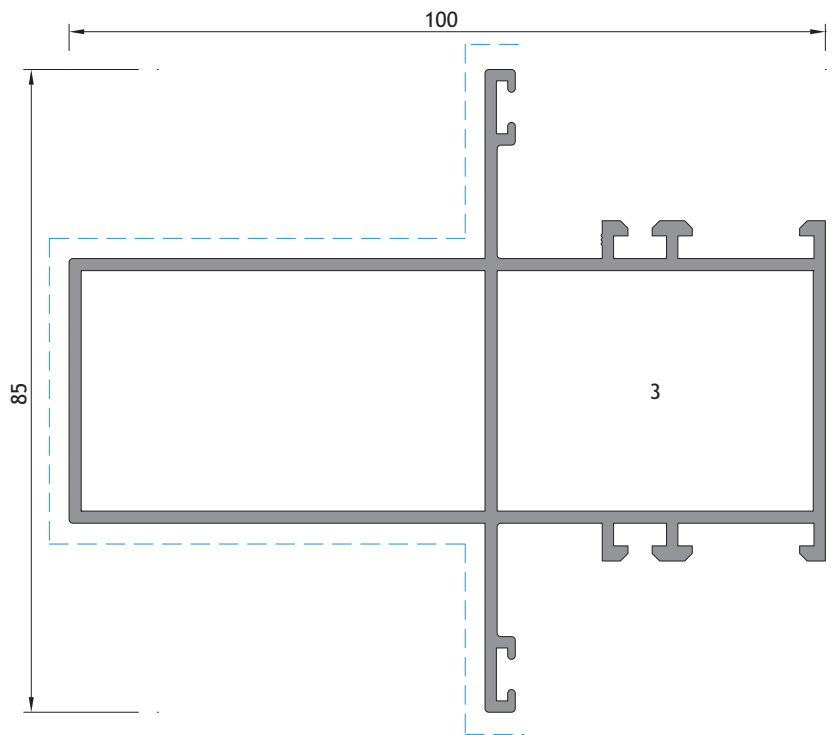
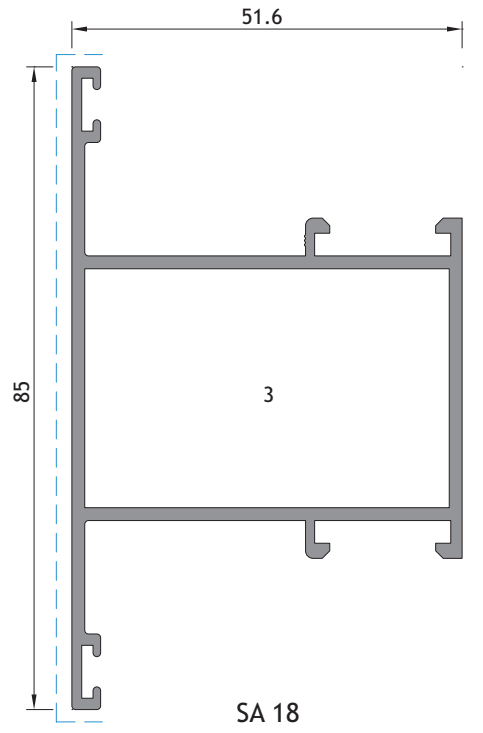
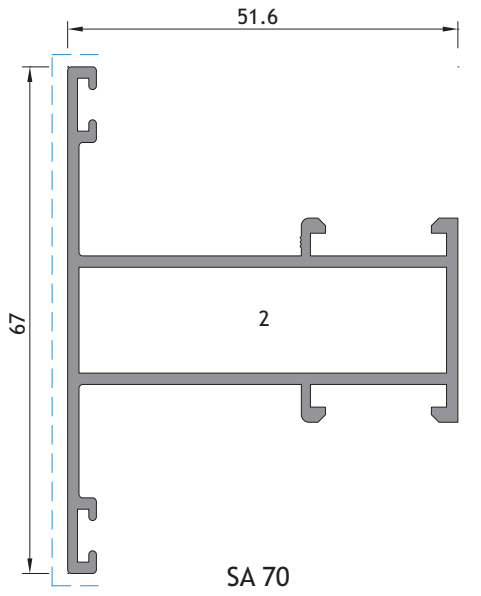

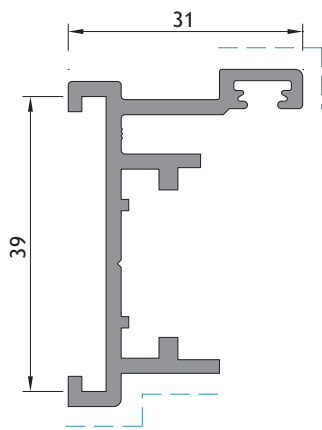

PS 00

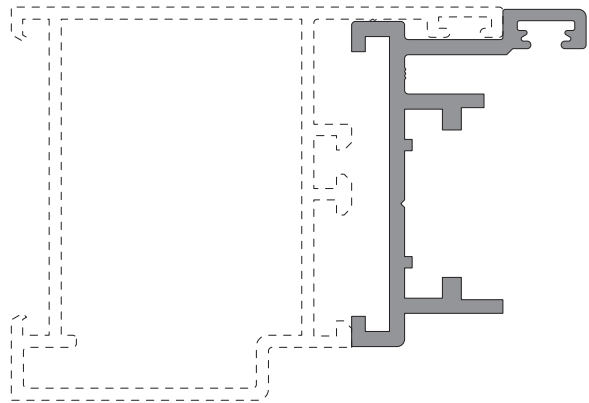

MONTAGEM  
ASSEMBLY  
MONTAGE

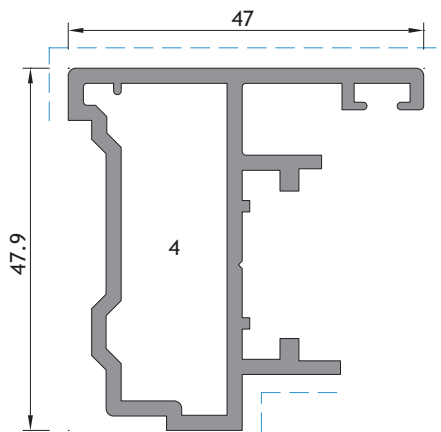

PS 83

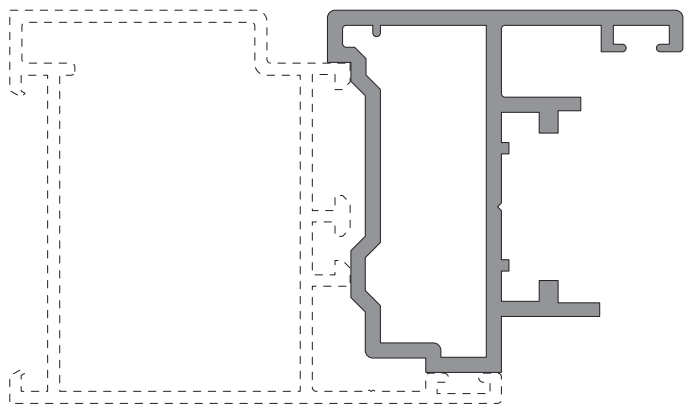

MONTAGEM  
ASSEMBLY  
MONTAGE

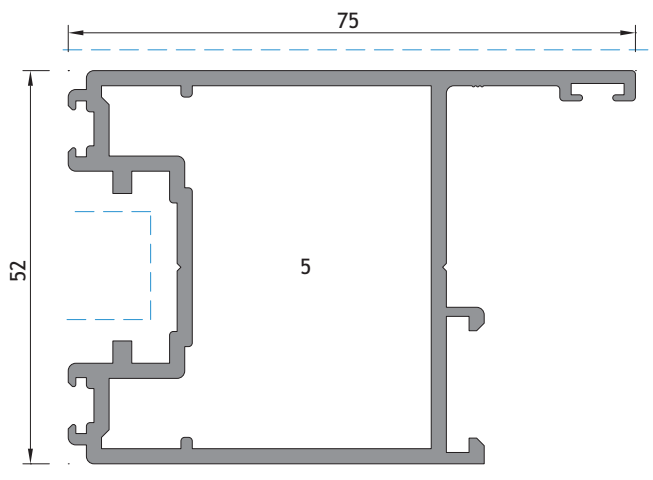

PS 25

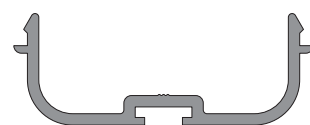

SA 25

TABELA DE BITES | GLAZING BEADS | PARCLOSES

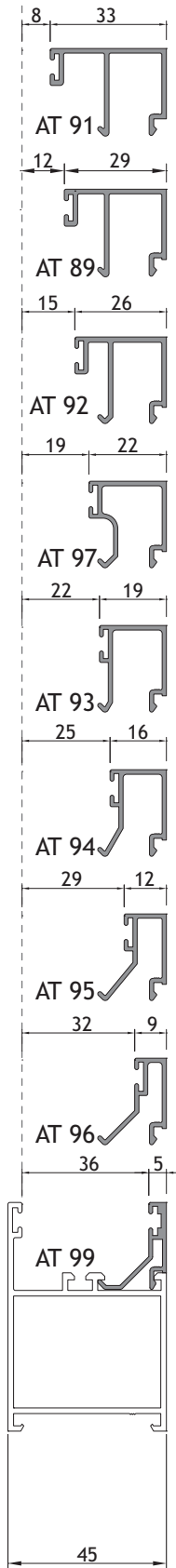

PERFIS DE 45mm  
PROFILES OF 45mm  
PROFILS DE 45mm

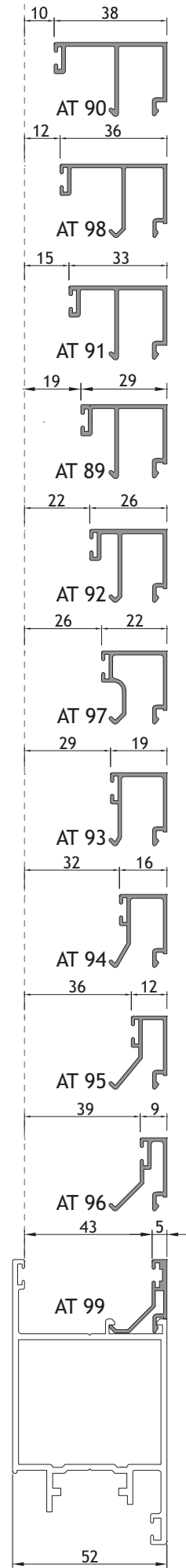

PERFIS DE 52mm  
PROFILES OF 52mm  
PROFILS DE 52mm



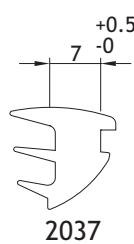
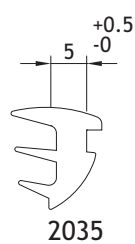
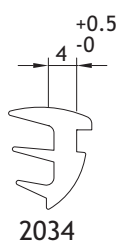
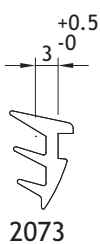
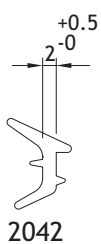
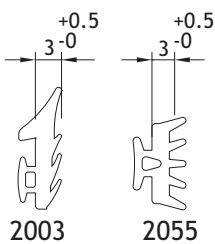
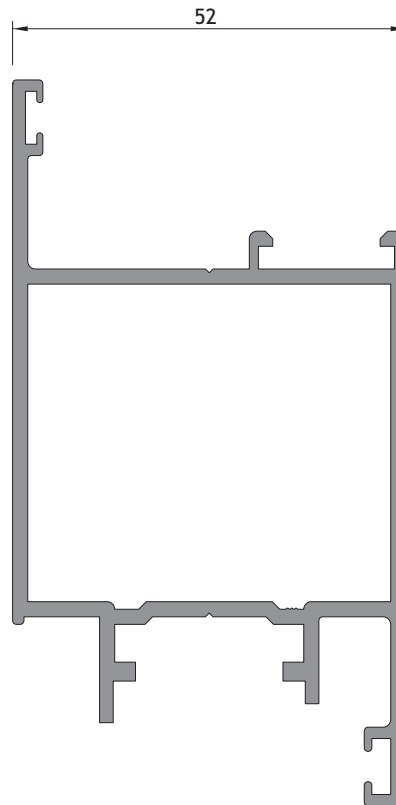
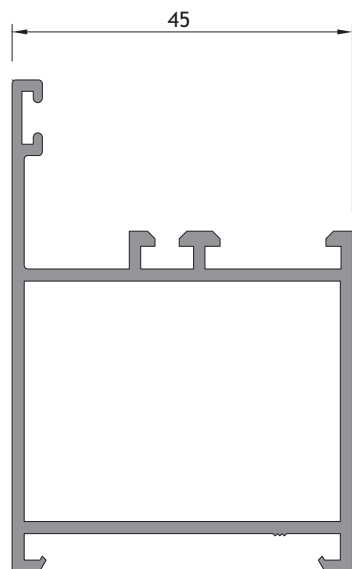

**TABELA DE BITES PARA PERFIS DE 45mm**

GLAZING BEADS SCHEDULE FOR 45mm PROFILES

TABLE DES PARCLOSES POUR PROFILS DE 45mm

VEDANTE EXTERIOR OUTER GASKET JOINT EXTÉRIEUR	ESPESSURA DO VIDRO THICKNESS OF GLASS ÉPAISSEUR DU VERRE	VEDANTE INTERIOR INNER GASKET JOINT INTÉRIEUR	BITES GLAZING BEAD PARCLOSE
2042	4	2042	AT 91
2003	5	2037	AT 92
2003	6	2035	AT 92
2003	8	2042	AT 89
2003	10	2035	AT 97
2003	14	2034	AT 93
2003	16	2035	AT 94
2003	18	2034	AT 94
2003	20	2035	AT 95
2003	22	2034	AT 95
2003	24	2035	AT 96
2003	26	2034	AT 96
2003	27	2037	AT 99
2042	28	2042	AT 96
2003	29	2035	AT 99
2003	30	2034	AT 99
2003	32	2042	AT 99

**TABELA DE BITES PARA PERFIS DE 52mm**

GLAZING BEADS SCHEDULE FOR 52mm PROFILES

TABLE DES PARCLOSES POUR PROFILS DE 52mm

VEDANTE EXTERIOR OUTER GASKET JOINT EXTÉRIEUR	ESPESSURA DO VIDRO THICKNESS OF GLASS ÉPAISSEUR DU VERRE	VEDANTE INTERIOR INNER GASKET JOINT INTÉRIEUR	BITES GLAZING BEAD PARCLOSE
2042	4	2034	AT 90
2003	5	2037	AT 91
2003	6	2037	AT 91
2003	6	2034	AT 98
2003	8	2042	AT 98
2035	10	2037	AT 92
2042	14	2042	AT 89
2003	14	2035	AT 92
2003	16	2037	AT 97
2003	18	2035	AT 97
2003	20	2037	AT 93
2003	22	2034	AT 93
2003	24	2073	AT 93
2003	24	2035	AT 94
2003	26	2037	AT 95
2003	28	2035	AT 95
2003	30	2037	AT 96
2003	32	2034	AT 96
2003	34	2037	AT 99
2003	36	2035	AT 99
2003	37	2034	AT 99
2003	38	2073	AT 99
2003	39	2042	AT 99

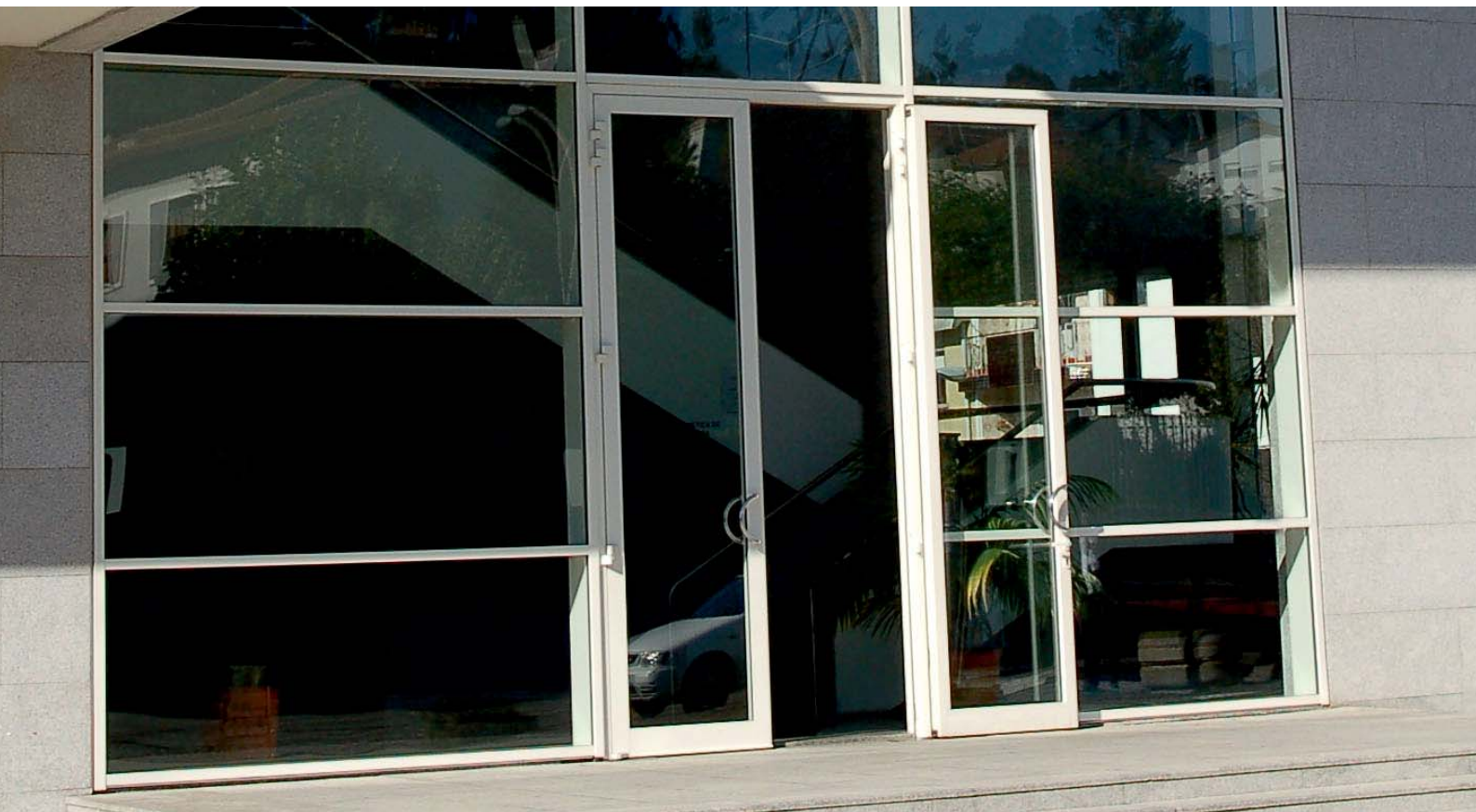

**Acessórios**  
Accessories  
Accessoires





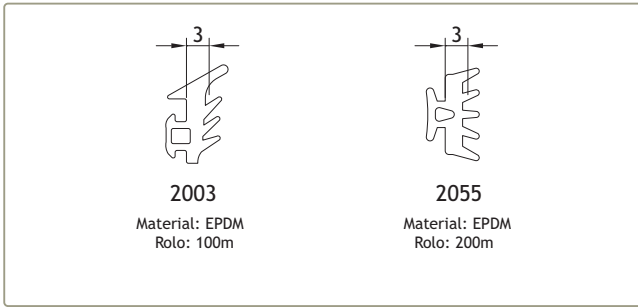

208350 JUNTA DE VEDAÇÃO EXTERIOR 2003  
208289 JUNTA DE BATENTE 2055

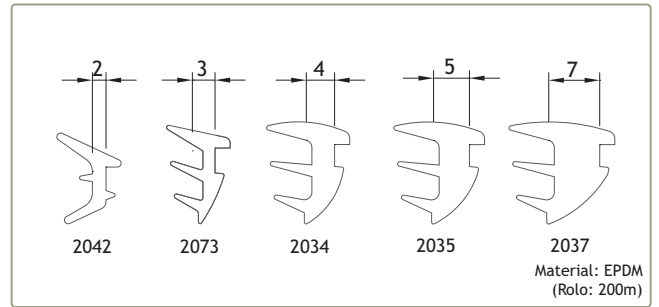

208191 JUNTA DE CUNHA 2042   208196 JUNTA DE CUNHA 2035  
208195 JUNTA DE CUNHA 2034   208904 JUNTA DE CUNHA 2037  
208199 JUNTA DE CUNHA 2073

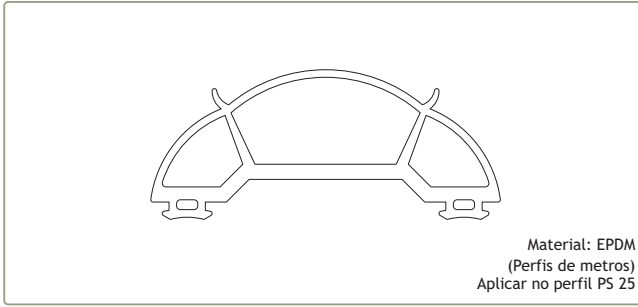

208001 JUNTA ANTI-ENTALAMENTO 2052

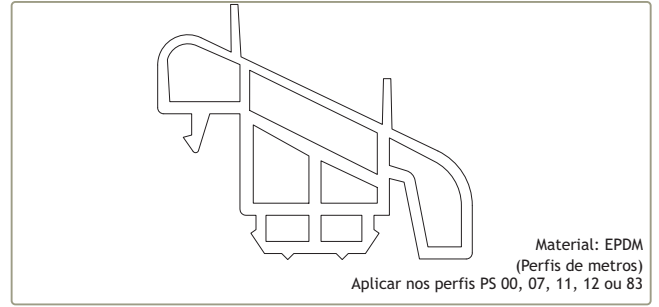

208011 JUNTA ANTI-ENTALAMENTO 2053

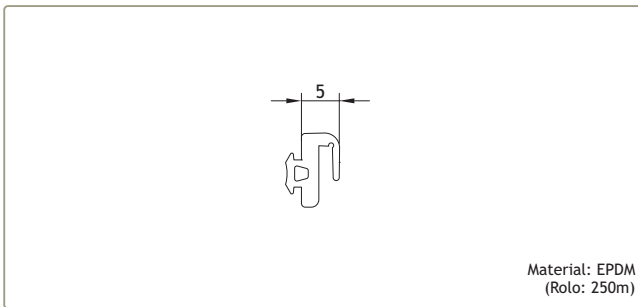

208114 JUNTA DE BATENTE 2008

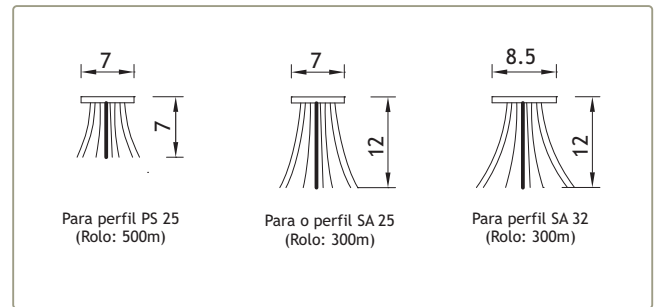

208460 JUNTA PELÚCIA 7x7 S-FIN  
208593 JUNTA PELÚCIA 7x12 S-FIN  
208464 JUNTA PELÚCIA 8.5x12 S-FIN

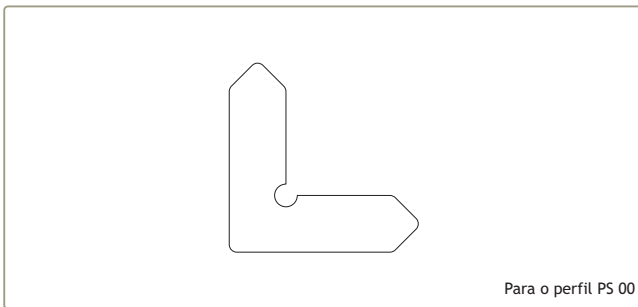

000000 CANTO CR 0705/500B

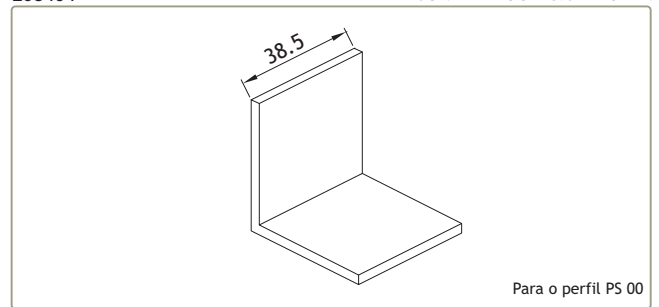

000000 CANTO CR 2006 Bruto

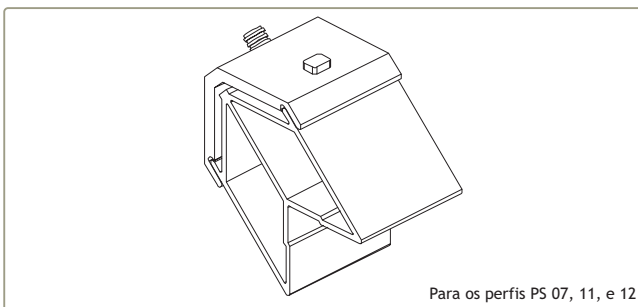

204801 ESQUADRO PS ESPECIAL GRANDE

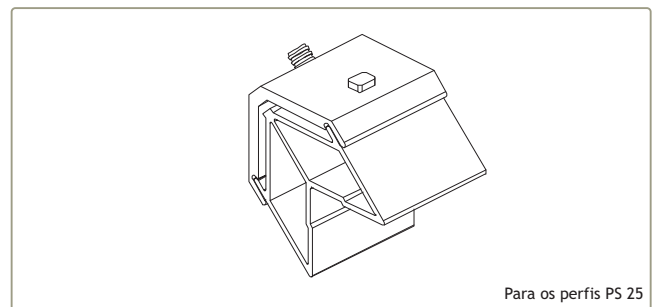

204002 ESQUADRO PS25 ESPECIAL GRANDE

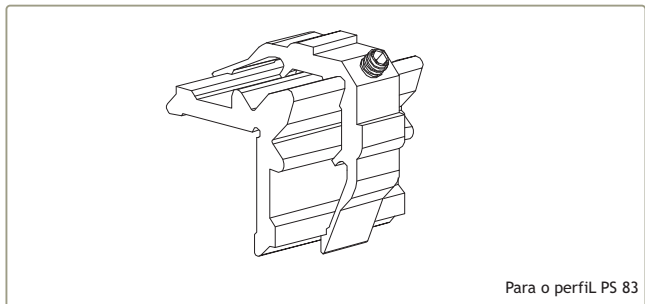

Para o perfil PS 83

204432 ESQUADRO SA 2000 PEQUENO

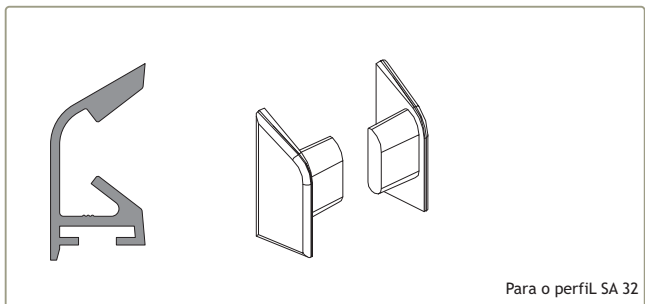

Para o perfil SA 32

212346 CONJ. TAPA-TOPOS SA 32 Br./Pr

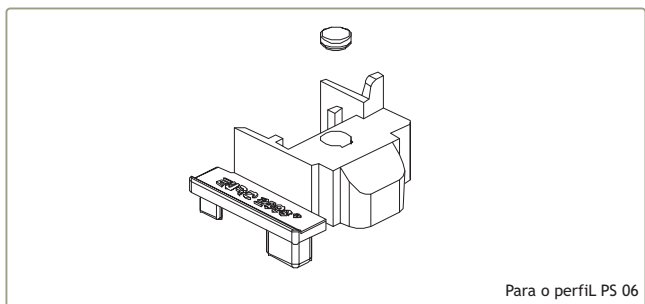

Para o perfil PS 06

207008 TAMPA INVERSOR PS ESQ Ny. (Br./Pr.)

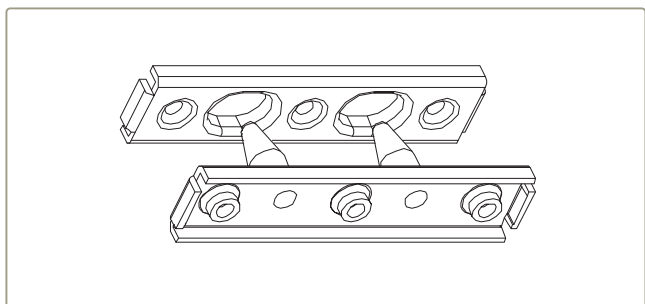

201611 FECHOS ANTI-ARROMBAMENTO 1459.3

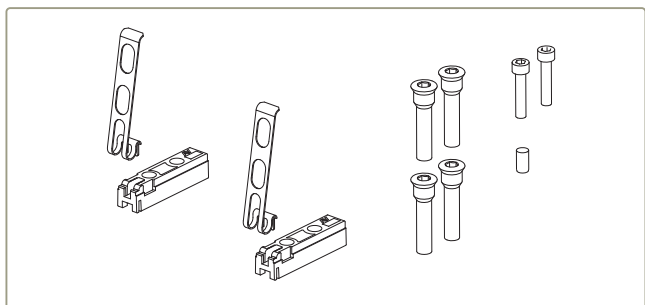

223100 KIT DE FIXAÇÃO PARA MECHANICA 1145.705

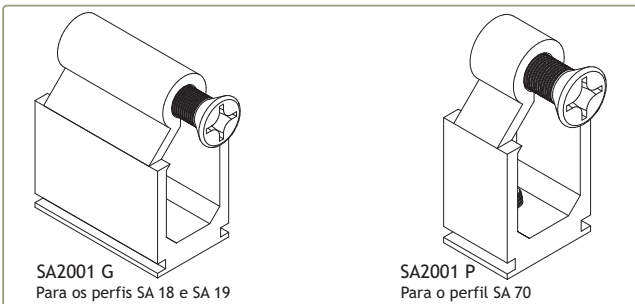

SA2001 G  
Para os perfis SA 18 e SA 19

SA2001 P  
Para o perfil SA 70

232116 UNIÃO TRAVESSAS SA2001 G  
290037 PARAFUSO SUPLEMENTAR P/UNIÃO SA2001 G INOX  
232118 UNIÃO TRAVESSAS SA2001 P

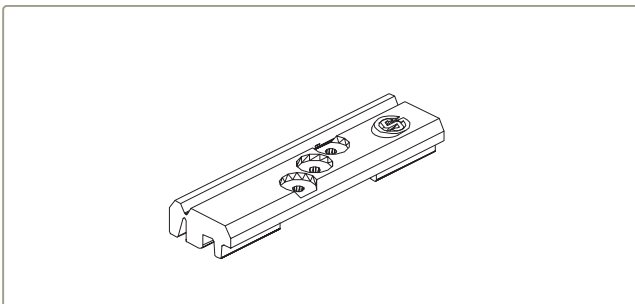

218194 CALÇO P/VIDRO EURO 2000 Nylon

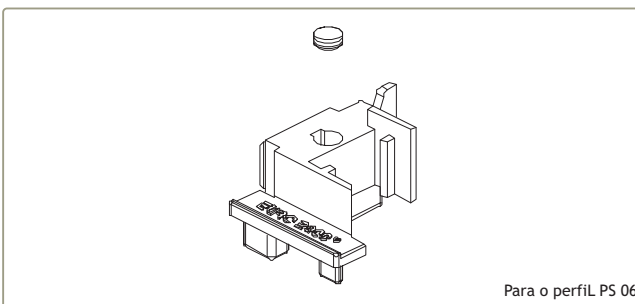

Para o perfil PS 06

207007 TAMPA INVERSOR PS DIR Ny. (Br./Pr.)

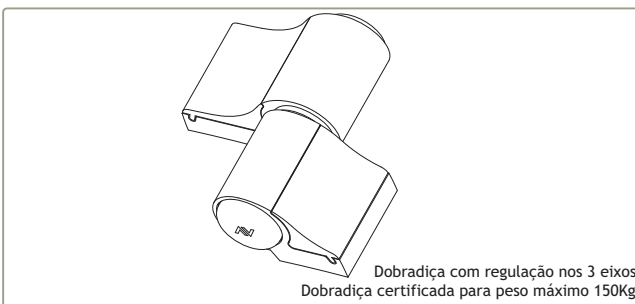

Dobradiça com regulação nos 3 eixos  
Dobradiça certificada para peso máximo 150Kg

202010 DOBRADIÇA MECHANICA 2 ABAS 1145/60  
202012 DOBRADIÇA MECHANICA 2 ABAS 1145/79  
202020 DOBRADIÇA MECHANICA 2 ABAS 1145/93SM

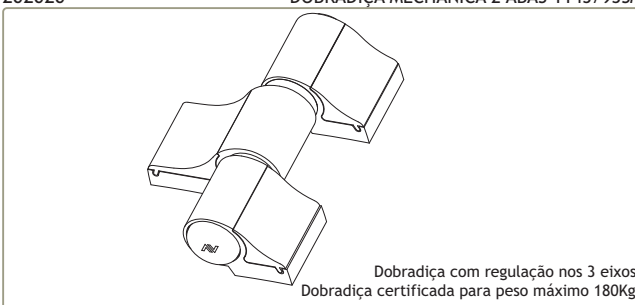

Dobradiça com regulação nos 3 eixos  
Dobradiça certificada para peso máximo 180Kg

202610 DOBRADIÇA MECHANICA 3 ABAS 1145.3/60



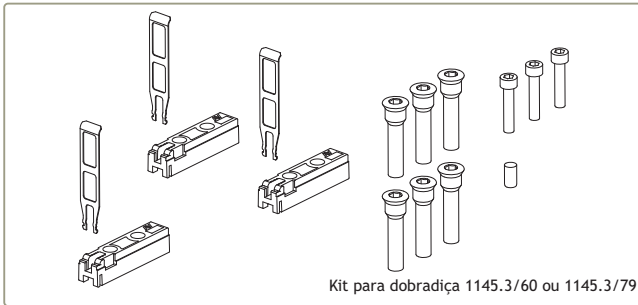

223020

KIT DE FIXAÇÃO PARA MECHANICA 1145.715

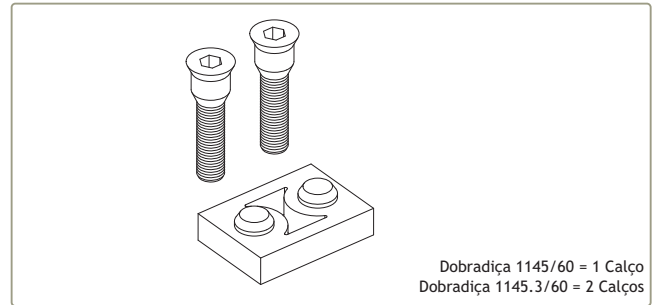

218170

CALÇO PARA DOBRADIÇA MECHANICA 1145.703/7



211101

GABARITO PARA FURAÇÃO 1145.908

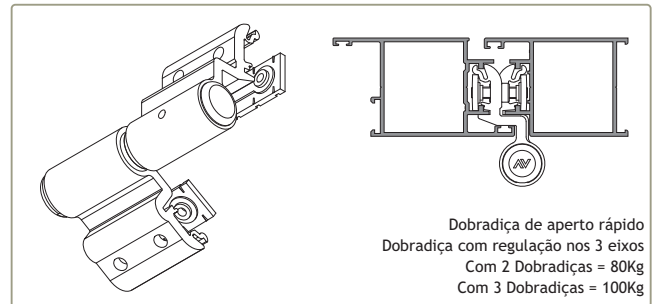

202507

DOBRADIÇA 2 ABAS 1148

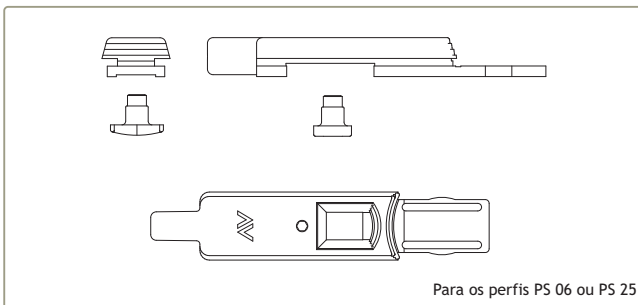

225001

PASSADOR PEQUENO 1541.10

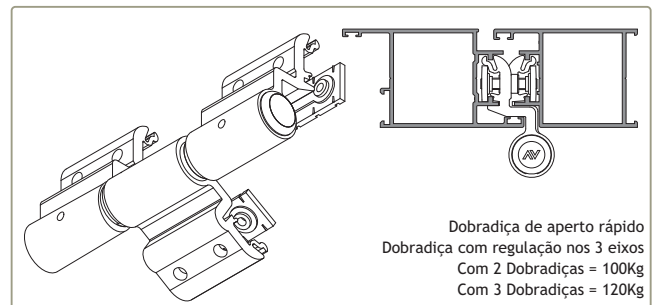

202014

DOBRADIÇA 3 ABAS 1148.3

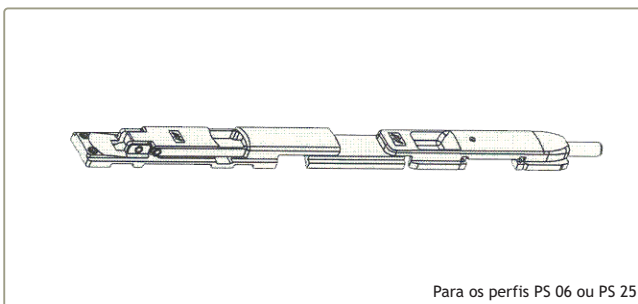

225002

PASSADOR 1556.5

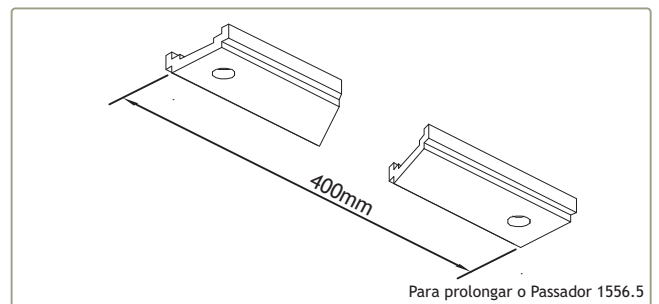

216001

ALONGAMENTO 1556.801 Preto

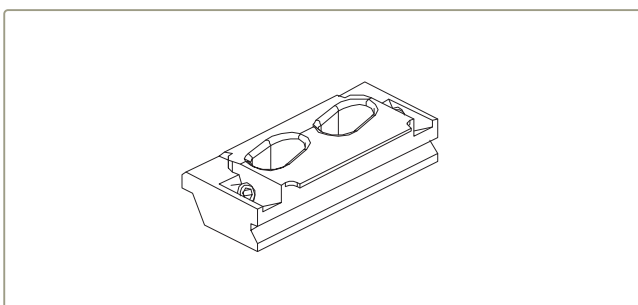

202403

CONTRA-FECHO DUPLO 1414.5

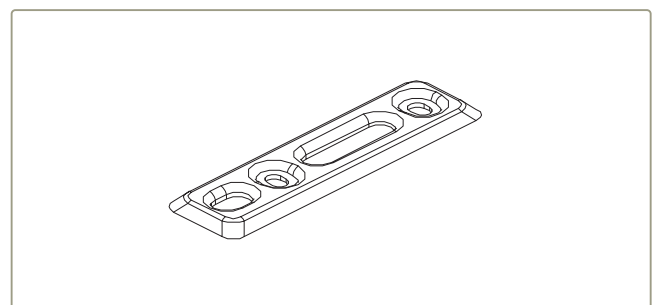

202407

CONTRA-FECHO INFERIOR 1408.1 INOX

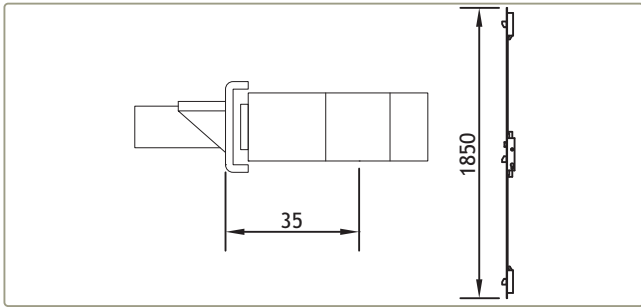

201010 FECHADURA DE 3 PONTOS EM U 7799x35

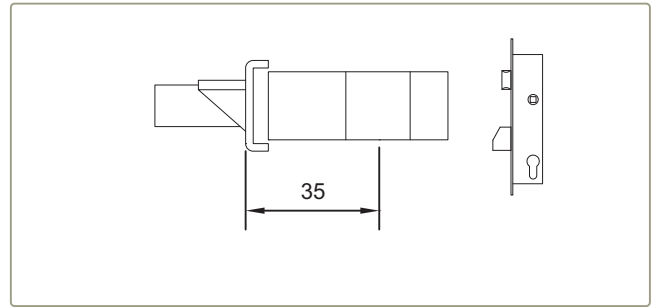

201012 FECHADURA PRUMO EM U 7797x35

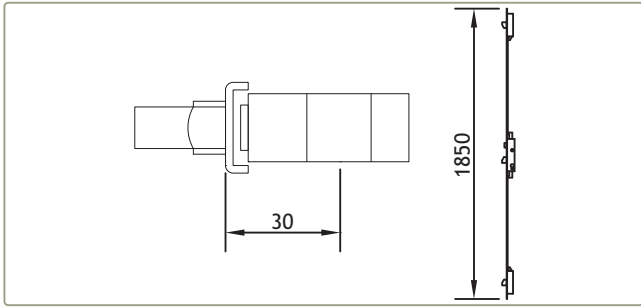

201612 FECHADURA DE 3 PONTOS VAI-VEM EM U 7799x30

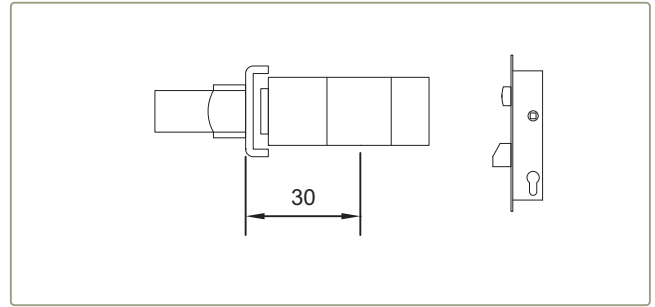

201014 FECHADURA PRUMO VAI-VEM EM U 7797x30

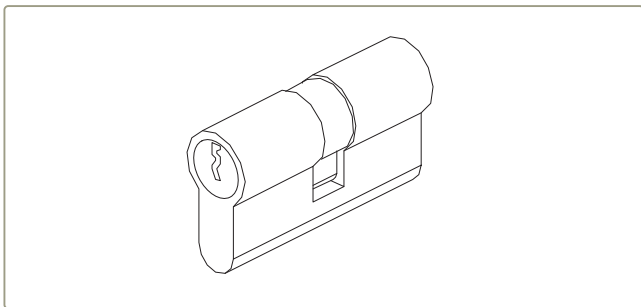

207400 CILINDRO BSK 35x35

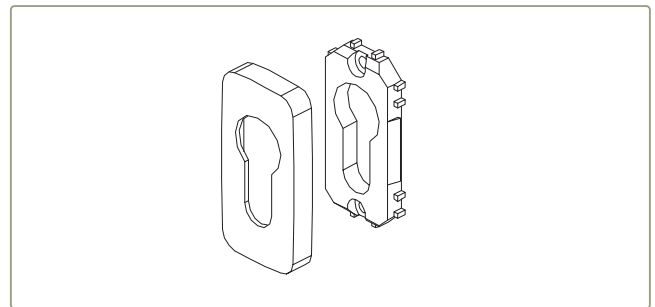

220190 ESPELHO 874.801

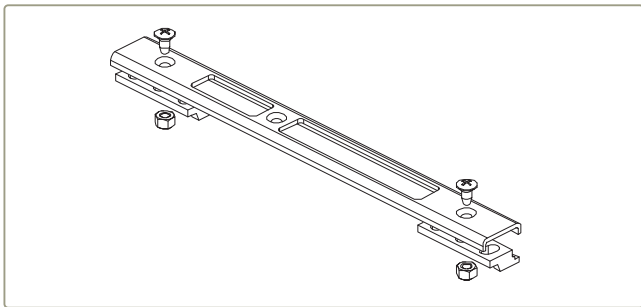

280004 TESTA PARA FECHADURA PS Nº1

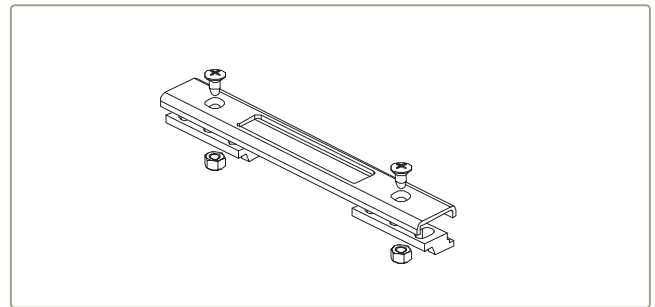

280005 TESTA PARA FECHADURA PS Nº2

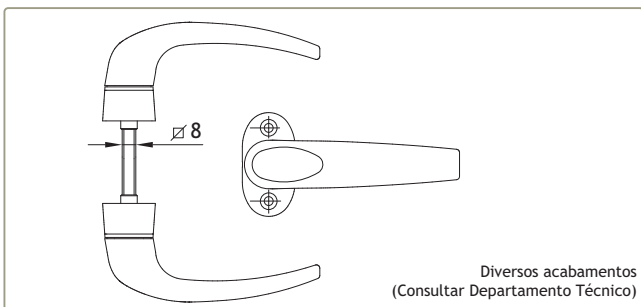

200747 PUXADOR DUPLO 874.31

Diversos acabamentos  
(Consultar Departamento Técnico)

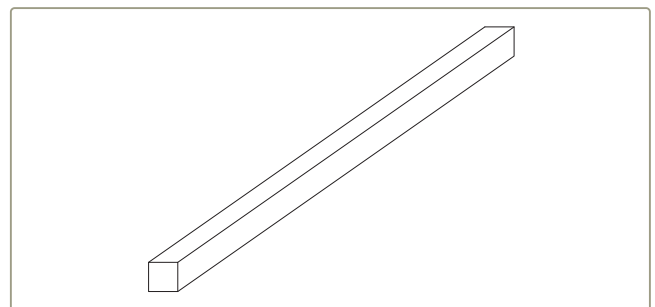

227301 QUADRAÇO 8mm PARA PUXADOR 874.31

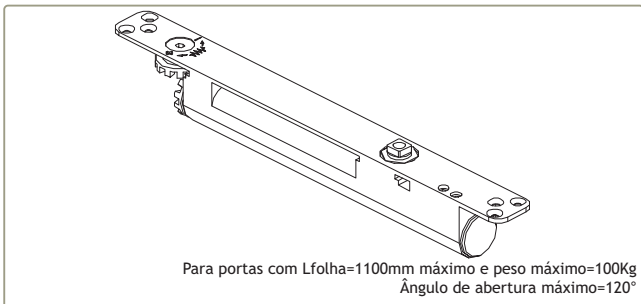

228051 MOLA SUP. OCULTA EN 2-4 ITS 96

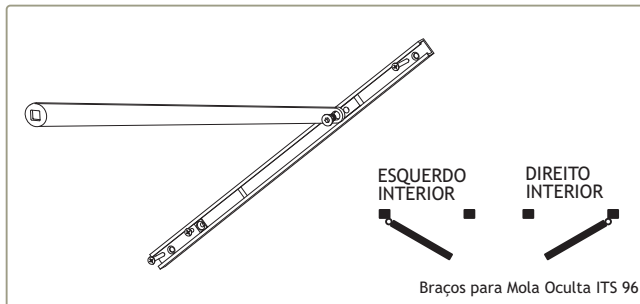

210117 BRAÇO P/ MOLA OCULTA G96 N20 ESQ.  
210118 BRAÇO P/ MOLA OCULTA G96 N20 DIR.

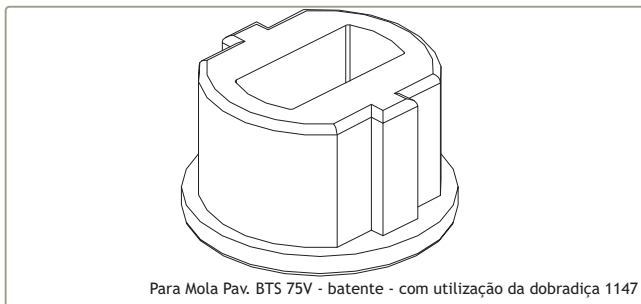

207327 SEPARADOR R. TER/1129.802 OXID



202511 DOBRADIÇA P/ MOLA 1147

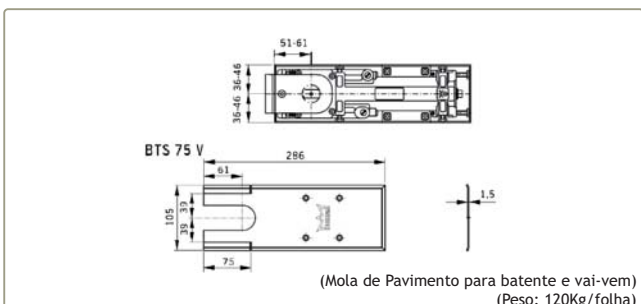

228071 MOLA DE PAVIMENTO BTS 75V



202510 DOBRADIÇA 2 ABAS 1132.1/60

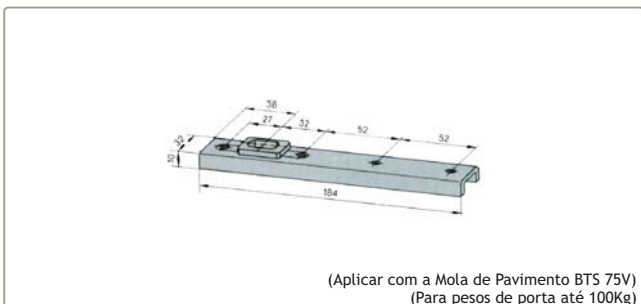

210104 BRAÇO INFERIOR VAI-VEM 8021

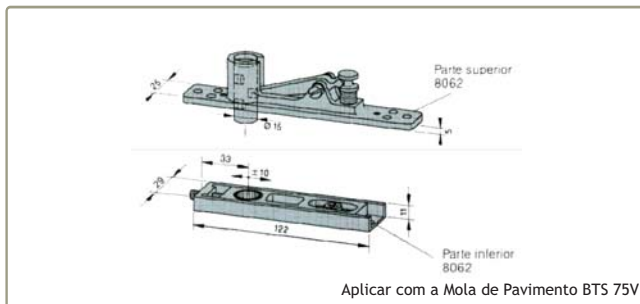

227111 PIVOT SUPERIOR VAI-VEM 8062



200970 ANTI-PÂNICO HORIZONTAL 6100.1/1085

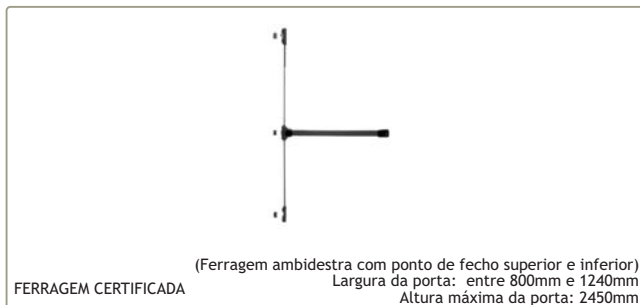

000000 ANTI-PÂNICO VERTICAL 6100.2/1085

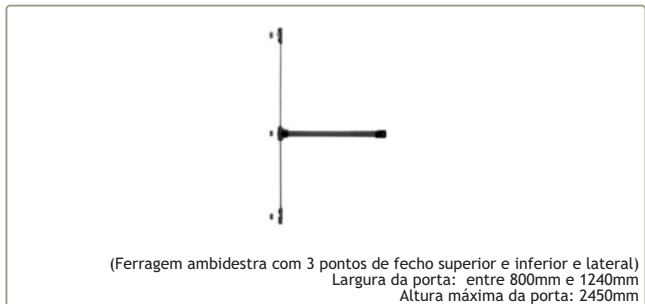

200971 ANTI-PÂNICO VERTICAL 6100.3/1085



200914 CREMONE COM FECHADURA 6000.875. Pr.



200912 ANTI-PÂNICO HORIZONTAL 6000.1/1200

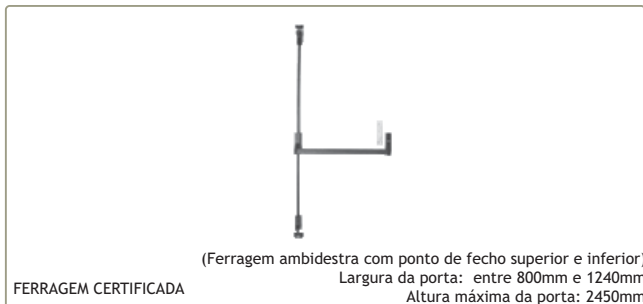

200968 ANTI-PÂNICO VERTICAL 6000.2/1200

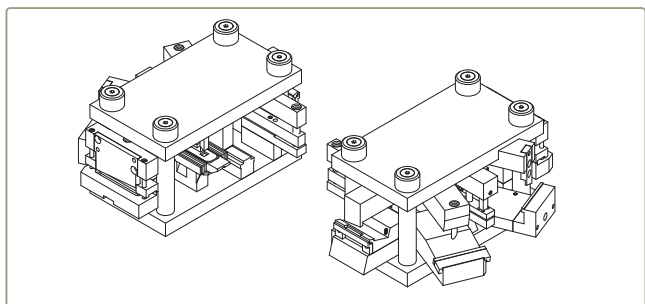

408033 CORTANTE SA 2000 + AT 2100

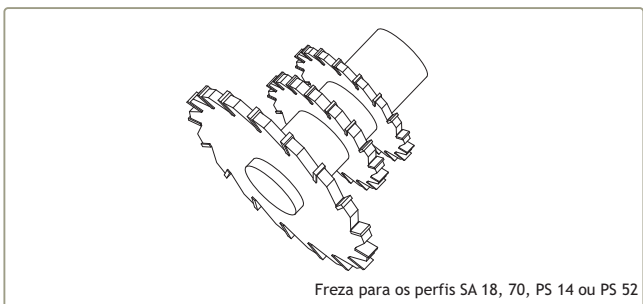

406001 CONJUNTO FREZA SÉRIE 2000 LINHA RETA



208704 PRODUTO DE LIMPEZA DE ALUMÍNIO (1L) Transparente



208019 SELA JUNTAS 150gr. (Cinza)



## **Pormenores de montagem**

Assembly details  
Détails d'assemblage





## PORTA DE 1 FOLHA - ABERTURA PARA INTERIOR

1 LEAF DOOR - OPENING FOR INSIDE

PORTE 1 VANTAIL - OUVERTURE VERS L'INTÉRIEUR

PERFIS PROFILES   PROFILS				
REFERÊNCIA REFERENCE RÉFÉRENCE	CORTE HORIZONTAL HORIZONTAL DETAIL DÉTAIL HORIZONTAL	CORTE VERTICAL VERTICAL DETAIL DÉTAIL VERTICALE	QUANTIDADE QUANTITY QUANTITÉ	CORTE CUT COUPÉ
PS 07	L	H	1+2	
PS 11	L-120	H-67	1+2	
PS 52	L-263	-	1	
SA 25	L-174	-	1	
SA 31	L-174	-	1	
SA 32	L-174	-	1	
Opção Option	-	-	2+2	

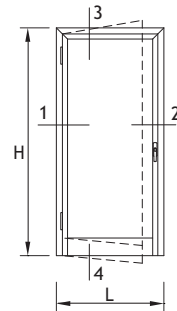

ACESSÓRIOS ACCESSORIES   ACCESSOIRES		
CÓDIGO CODE	DESIGNAÇÃO DESIGNATION   DÉSIGNATION	QUANTIDADE QUANTITY   QUANTITÉ
204801	ESQUADRO PS E. G.   BLOCKING BRACKET   ÉQUERRE	4
202010	DOB. MECHANICA 1145/60   HINGE   PAUMELLE	2
223100	KIT DOB. MECHANICA 1145/705   HINGE KIT   KIT P/PAUMELLE	2
201611	FECHO ANTI-ARROMB. 1459.3   ANTI-BREAK-IN LOCKER   SERRURE ANTI-EFFRACTION	2
207400	CILINDRO BSK 35x35   CYLINDER LOCK   CYLINDRE DE SERRURE	1
220190	ESPELHO 874.801   CYLINDER BACK PLATE   COUVERCLE DE CYLINDRE	2
201010	FECH. 3 PONTOS U 7799x35   3 POINTS LOCKER   SERRURE DE 3 POINTS	1
280004	TESTA FECHADURA PS Nº.1   STRICKING PLATE   GÂCHE	1
280005	TESTA FECHADURA PS Nº.2   STRICKING PLATE   GÂCHE	2
200747	PUXADOR DUPLO 874.31   DOUBLE HANDLE   POIGNÉE DOUBLE	1
212346	CONJUNTO TAPA-TOPOS SA32   END-CAP KIT   KIT DE EMBOUTE	1
210154	GOTEIRA 1875   DRIP   GOÛTTIÈRE	2
218194	CALÇOS P/VIDRO EURO 2000   GLAZING SHIM   CALE P/VITRAGE	Opção   Option   Option

VEDANTES SEALANTS   JOINTS		
CÓDIGO CODE	DESIGNAÇÃO DESIGNATION   DÉSIGNATION	QUANTIDADE QUANTITY   QUANTITÉ
208114	VD 2008	2L+4H
208350	VD 2003	2L+2H
VARIÁVEL VARIABLE	JUNTA INTERIOR   GLAZING WEDGE GASKET   JOINT INTÉRIEUR	2L+2H
208593	PELÚCIA 7x12 STOP-FIN   PLUSH   JOINT BROUSSE (SA 25)	L
208464	PELÚCIA 8.5x12 STOP-FIN   PLUSH   JOINT BROUSSE (SA 32)	L

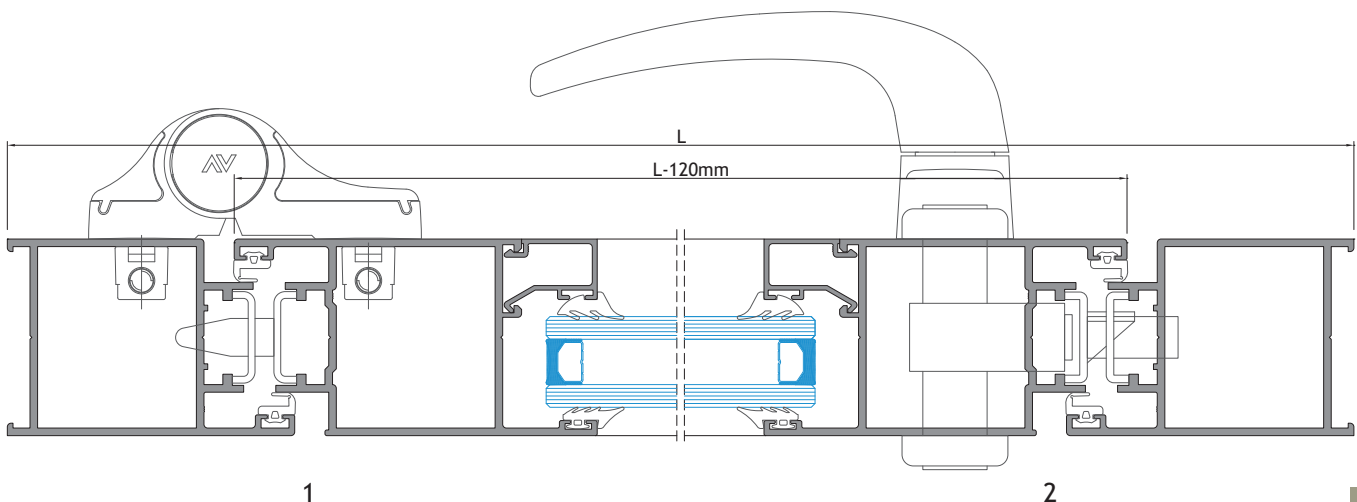
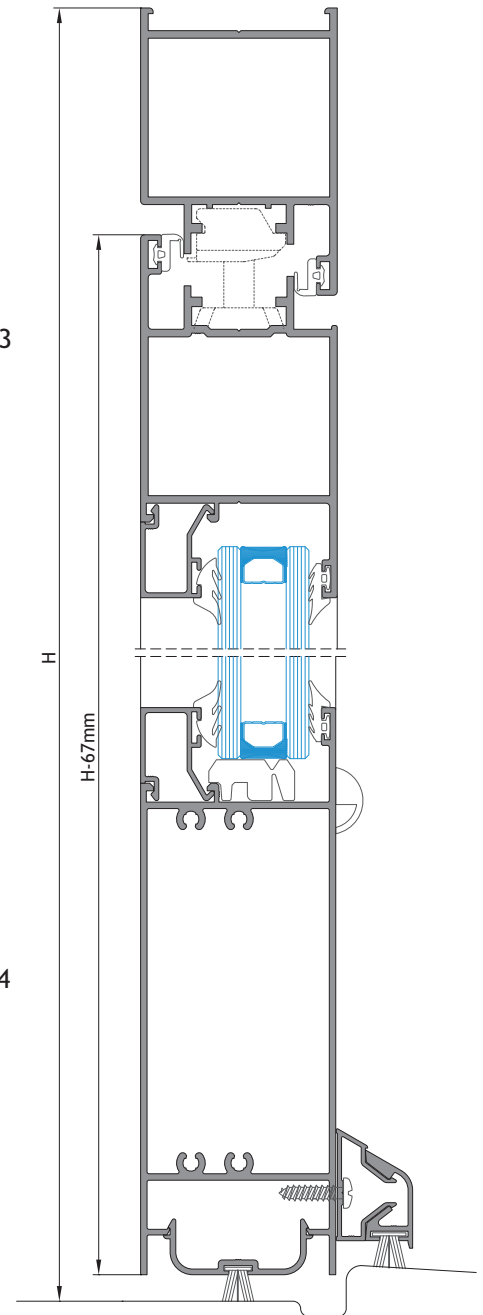

ESC: 1/2

**PORTA DE ABERTURA PARA EXTERIOR**  
 OUTWARD OPENING DOOR  
 PORTE DE OUVERTURE VERS L'EXTÉRIEUR

PERFIS PROFILES   PROFILS				
REFERÊNCIA REFERENCE RÉFÉRENCE	CORTE HORIZONTAL HORIZONTAL DETAIL DÉTAIL HORIZONTAL	CORTE VERTICAL VERTICAL DETAIL DÉTAIL VERTICALE	QUANTIDADE QUANTITY QUANTITÉ	CORTE CUT COUPÉ
PS 07	L	H	1+2	
PS 12	L-120	H-67	1+2	
PS 52	L-263	-	1	
SA 25	L-174	-	1	
Opção Option	-	-	2+2	

ACESSÓRIOS ACCESSORIES   ACCESSOIRES		
CÓDIGO CODE	DESIGNAÇÃO DESIGNATION   DÉSIGNATION	QUANTIDADE QUANTITY   QUANTITÉ
204801	ESQUADRO PS E. G.   BLOCKING BRACKET   ÉQUERRE	4
202010	DOB. MECHANICA 1145/60   HINGE   PAUMELLE	2
223100	KIT DOB. MECHANICA 1145/705   HINGE KIT   KIT P/PAUMELLE	2
201611	FECHO ANTI-ARROMB. 1459.3   ANTI-BREAK-IN LOCKER   SERRURE ANTI-EFFRACTION	2
207400	CILINDRO BSK 35x35   CYLINDER LOCK   CYLINDRE DE SERRURE	1
220190	ESPELHO 874.801   CYLINDER BACK PLATE   COUVERCLE DE CYLINDRE	2
201010	FECH. 3 PONTOS U 7799x35   3 POINTS LOCKER   SERRURE DE 3 POINTS	1
280004	TESTA FECHADURA PS Nº.1   STRICKING PLATE   GÂCHE	1
280005	TESTA FECHADURA PS Nº.2   STRICKING PLATE   GÂCHE	2
200747	PUXADOR DUPLO 874.31   DOUBLE HANDLE   POIGNÉE DOUBLE	1
210154	GOTEIRA 1875   DRIP   GOUTTIÈRE	2
218194	CALÇOS P/VIDRO EURO 2000   GLAZING SHIM   CALE P/VITRAGE	Opção   Option   Option

VEDANTES SEALANTS   JOINTS		
CÓDIGO CODE	DESIGNAÇÃO DESIGNATION   DÉSIGNATION	QUANTIDADE QUANTITY   QUANTITÉ
208114	VD 2008	2L+4H
208350	VD 2003	2L+2H
VARIÁVEL VARIABLE	JUNTA INTERIOR   GLAZING WEDGE GASKET   JOINT INTÉRIEUR	2L+2H
208593	PELÚCIA 7x12 STOP-FIN   PLUSH   JOINT BROSSÉ (SA 25)	L

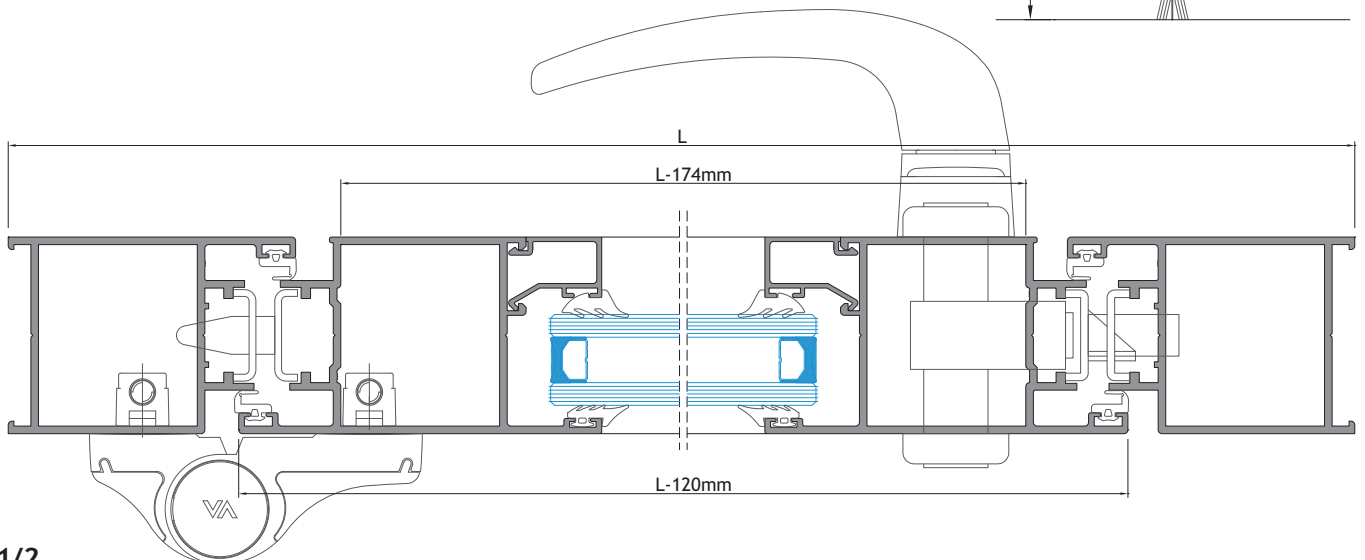
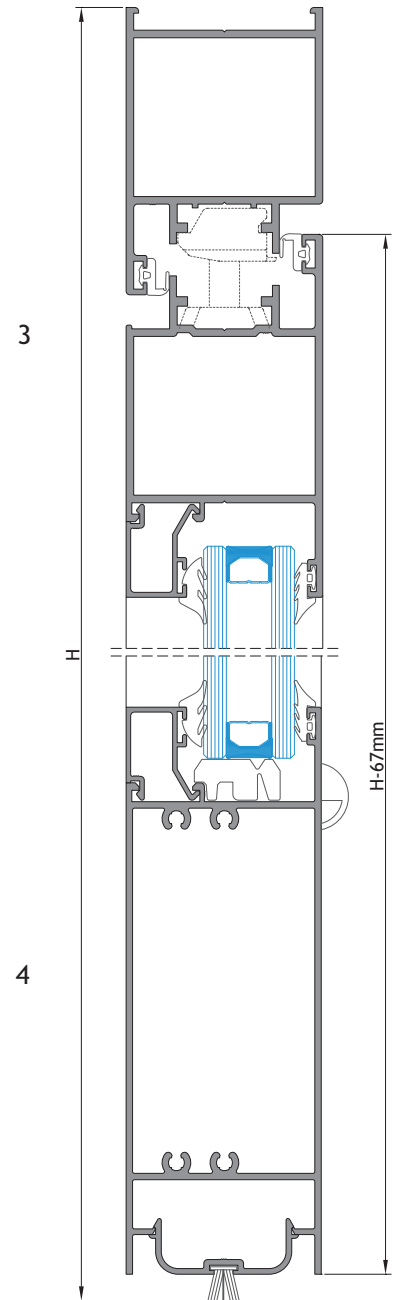
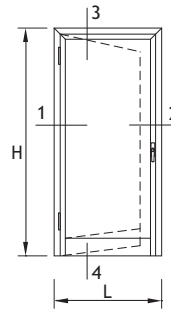



### PORTA DE VAI-VEM DE 1 FOLHA

1 LEAF SWING DOOR

PORTE VA-ET-VIEN 1 VANTAIL

PERFIS PROFILES   PROFILS				
REFERÊNCIA REFERENCE RÉFÉRENCE	CORTE HORIZONTAL HORIZONTAL DETAIL DÉTAIL HORIZONTAL	CORTE VERTICAL VERTICAL DETAIL DÉTAIL VERTICALE	QUANTIDADE QUANTITY QUANTITÉ	CORTE CUT COUPÉ
PS 25	L	H	1+2	
PS 25	L-160	H-87	1+2	
PS 52	L-261	-	1	
SA 25	L-193	-	1	
KP 40	L	H	1+2	
Opção Option	-	-	2+2	

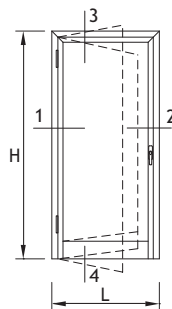

ACESSÓRIOS ACCESSORIES   ACCESSOIRES		
CÓDIGO CODE	DESIGNAÇÃO DESIGNATION   DÉSIGNATION	QUANTIDADE QUANTITY   QUANTITÉ
204002	ESQUADRO PS 25 E. G.   BLOCKING BRACKET   ÉQUERRE	4
228071	MOLA DE CHÃO BTS 75V   FLOOR SPRING   PIVOT À FREIN	1
227111	PIVOT SUPERIOR VAI-VEM 8062   UPPER PIVOT HINGE   PIVOT SUPÉRIEUR	1
210104	BRAÇO INFERIOR VAI-VEM 8021   LOWER PIVOT HINGE   PIVOT INFÉRIEUR	1
207400	CILINDRO BSK 35x35   CYLINDER LOCK   CYLINDRE DE SERRURE	1
220190	ESPELHO 874.801   CYLINDER BACK PLATE   COUVERCLE DE CYLINDRE	2
201612	FECH. 3 PONTOS VAI-VEM U7799x30   3 POINTS LOCKER   SERRURE DE 3 POINTS	1
280004	TESTA FECHADURA PS Nº.1   STRICKING PLATE   GÂCHE	1
280005	TESTA FECHADURA PS Nº.2   STRICKING PLATE   GÂCHE	2
200747	PUXADOR DUPLO 874.31   DOUBLE HANDLE   POIGNÉE DOUBLE	1
210154	GOTEIRA 1875   DRIP   GOUÏTIÈRE	2
218194	CALÇOS P/VIDRO EURO 2000   GLAZING SHIM   CALE P/VITRAGE	Opção   Option   Option

VEDANTES SEALANTS   JOINTS		
CÓDIGO CODE	DESIGNAÇÃO DESIGNATION   DÉSIGNATION	QUANTIDADE QUANTITY   QUANTITÉ
208350	VD 2003	2L+2H
VARIÁVEL VARIABLE	JUNTA INTERIOR   GLAZING WEDGE GASKET   JOINT INTÉRIEUR	2L+2H
208460	PELÚCIA 7x7 STOP-FIN   PLUSH   JOINT BROSSE (PS 25)	4L+8H
208593	PELÚCIA 7x12 STOP-FIN   PLUSH   JOINT BROSSE (SA 25)	L

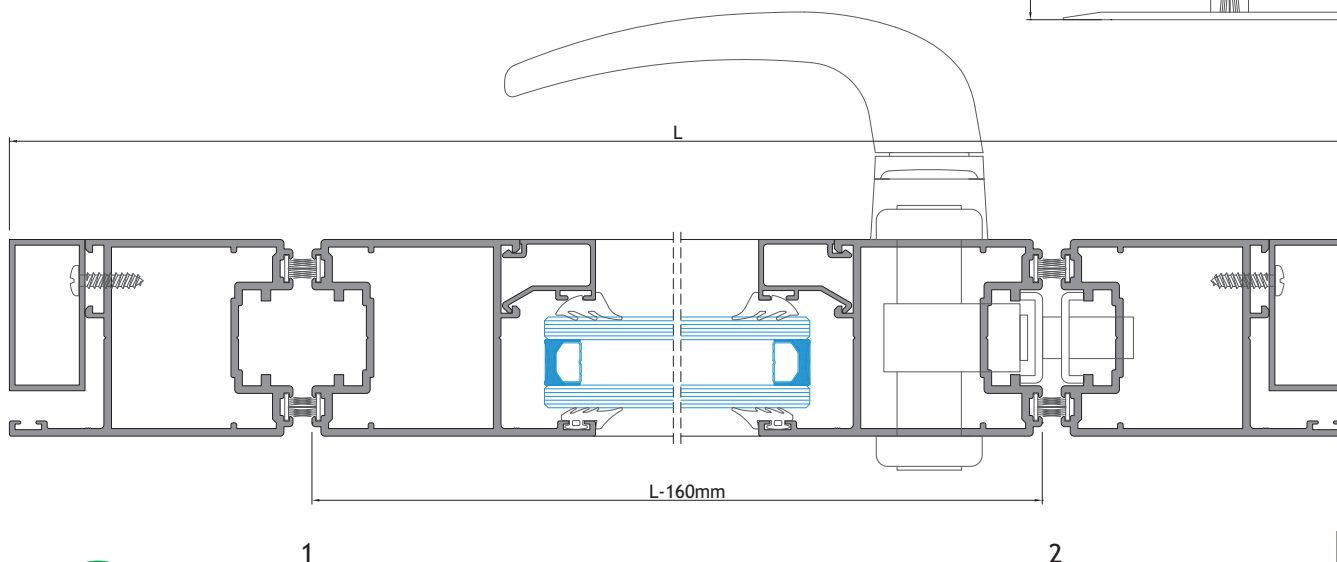
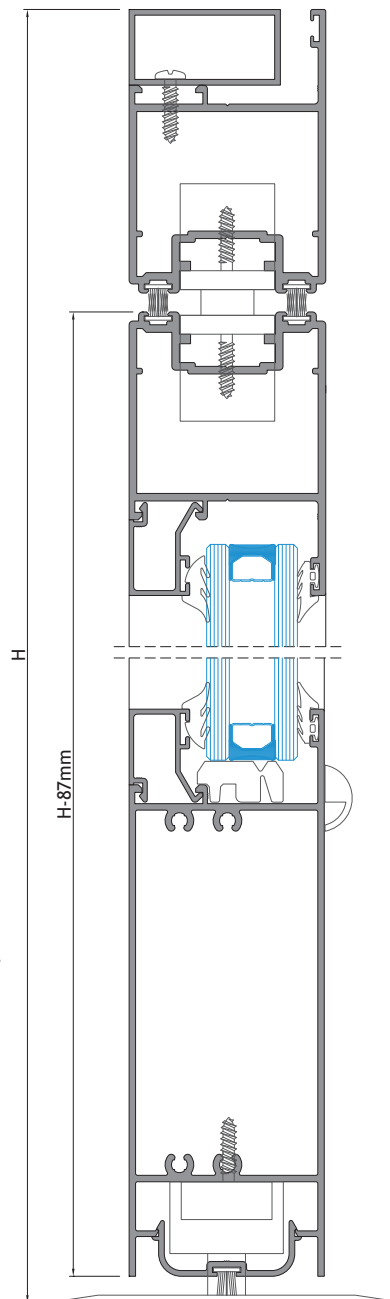

**PORTA DE 2 FOLHAS - ABERTURA PARA INTERIOR**

2 LEAVES DOOR - INWARD OPENING

PORTE 2 VANTAUX - OUVERTURE VERS L'INTÉRIEUR

PERFIS PROFILES   PROFILS				
REFERÊNCIA REFERANCE RÉFÉRENCE	CORTE HORIZONTAL HORIZONTAL DETAIL DÉTAIL HORIZONTAL	CORTE VERTICAL VERTICAL DETAIL DÉTAIL VERTICALE	QUANTIDADE QUANTITY QUANTITÉ	CORTE CUT COUPÉ
PS 07	L	H	1+2	
PS 11	(L-128)/2	H-67	2+4	
PS 52	(L-414)/2	-	2	
PS 06	-	H-95	1	
SA 25	(L-236)/2	-	2	
SA 31	(L-232)/2 [(L-232)/2]+48	-	1	
SA 32	(L-232)/2 [(L-232)/2]+48	-	1	
Opção Option	-	-	4+4	

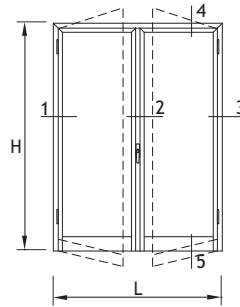

ACESSÓRIOS ACCESSORIES   ACCESSOIRES		
CÓDIGO CODE	DESIGNAÇÃO DESIGNATION   DÉSIGNATION	QUANTIDADE QUANTITY   QUANTITÉ
204801	ESQUADRO PS E. G.   BLOCKING BRACKET   ÉQUERRE	6
202010	DOB. MECANICA 1145/60   HINGE   PAUMELLE	4
223100	KIT DOB. MECANICA 1145/705   HINGE KIT   KIT P/PAUMELLE	4
201611	FECHO ANTI-ARROMB. 1459.3   ANTI-BREAK-IN LOCKER   SERRURE ANTI-EFFRACTION	4
207400	CILINDRO BSK 35x35   CYLINDER LOCK   CYLINDRE DE SERRURE	1
220190	ESPELHO 874.801   CYLINDER BACK PLATE   COUVERCLE DE CYLINDRE	2
201010	FECH. 3 PONTOS U 7799x35   3 POINTS LOCKER   SERRURE DE 3 POINTS	1
280004	TESTA FECHADURA PS Nº.1   STRICKING PLATE   GÂCHE	1
280005	TESTA FECHADURA PS Nº.2   STRICKING PLATE   GÂCHE	2
200747	PUXADOR DUPLO 874.31   DOUBLE HANDLE   POIGNÉE DOUBLE	1
212346	CONJUNTO TAPA-TOPOS SA32   END-CAP KIT   KIT DE EMBOUTE	1
202403	CONTRA FECHO DUPLO 1414.5   COUNTER-LOCK   CONTRE-FERMETURE	1
202407	CONTRA FECHO INFERIOR 1408.1   COUNTER-LOCK   CONTRE-FERMETURE	1
225001	PASSADOR PEQUENO 1541.10   LEAF LOCKER   FERMETURE POUR VANTAIL	2
207008-Esq 207007-Dir	TAMPA INVERSOR PS (Esq ou Dir)   END-CAP (Lef or Right)   EMBOUTE (Gauche ou Droite)	1
212346	CONJUNTO TAPA-TOPOS SA32   END-CAP KIT   KIT DE EMBOUTE	1
210154	GOTEIRA 1875   DRIP   GOUITTIÈRE	2
218194	CALÇOS P/VIDRO EURO 2000   GLAZING SHIM   CALE P/VITRAGE	Opção   Option   Option

VEDANTES SEALANTS   JOINTS		
CÓDIGO CODE	DESIGNAÇÃO DESIGNATION   DÉSIGNATION	QUANTIDADE QUANTITY   QUANTITÉ
208114	VD 2008	2L+6H
208350	VD 2003	2L+4H
VARIÁVEL VARIABLE	JUNTA INTERIOR   GLAZING WEDGE GASKET   JOINT INTÉRIEUR	2L+4H
208593	PELÚCIA 7x12 STOP-FIN   PLUSH   JOINT BROSSE (SA 25)	L
208464	PELÚCIA 8.5x12 STOP-FIN   PLUSH   JOINT BROSSE (SA 32)	L

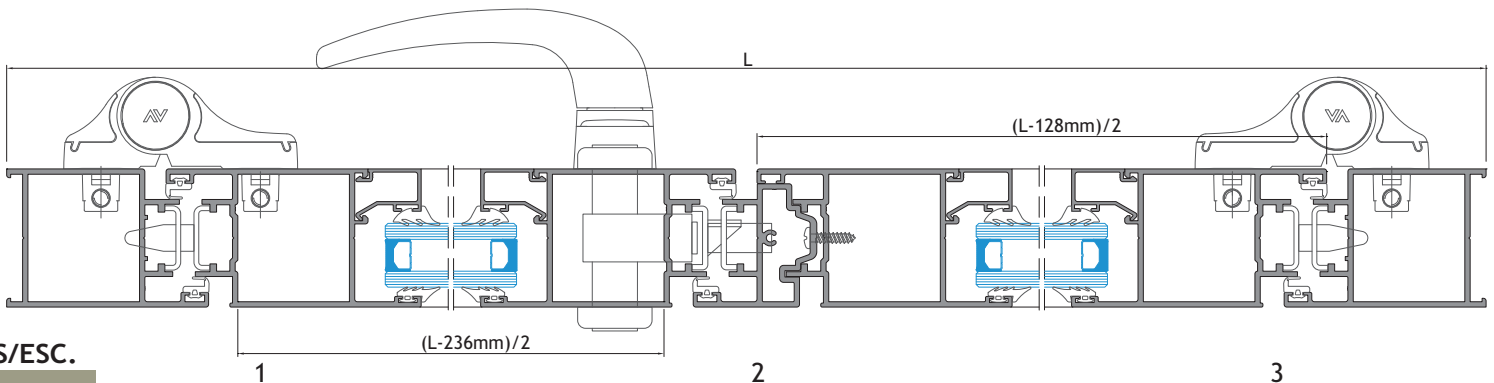
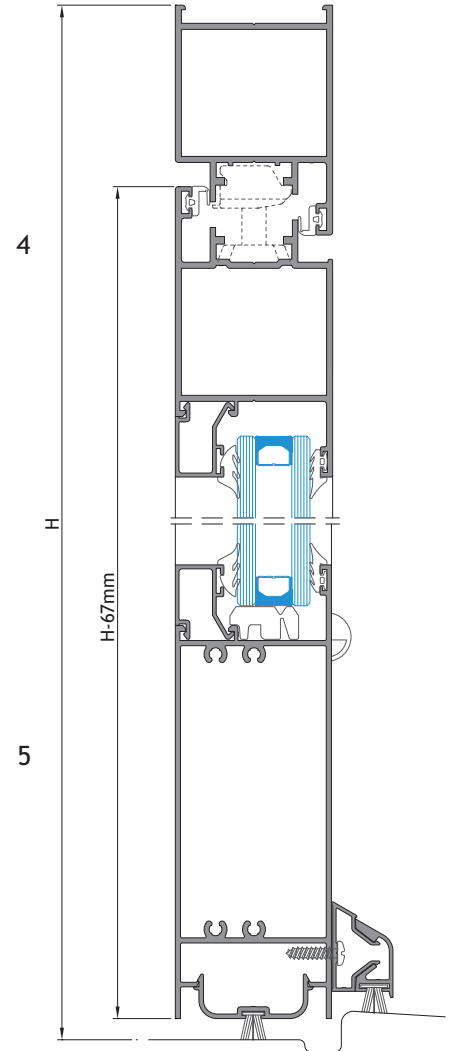

S/ESC.



**PORTA DE 2 FOLHAS - ABERTURA PARA EXTERIOR**

2 LEAVES DOOR - OUTWARD OPENING

PORTE 2 VANTAUX - OUVERTURE VERS L'EXTÉRIEUR

PERFIS PROFILES   PROFILS				
REFERÊNCIA REFERENC RÉFÉRENCE	CORTE HORIZONTAL HORIZONTAL DETAIL DÉTAIL HORIZONTAL	CORTE VERTICAL VERTICAL DETAIL DÉTAIL VERTICALE	QUANTIDADE QUANTITY QUANTITÉ	CORTE CUT COUPÉ
PS 07	L	H	1+2	
PS 12	(L-128)/2	H-67	2+4	
PS 52	(L-414)/2	-	2	
SA 06	-	H-95	1	
SA 25	(L-236)/2	-	2	
Opção Option	-	-	4+4	

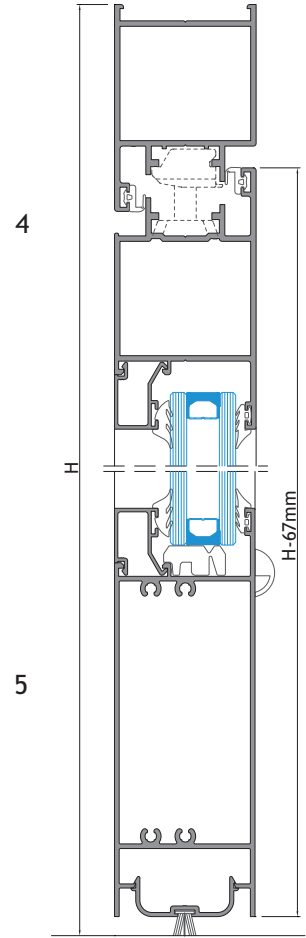
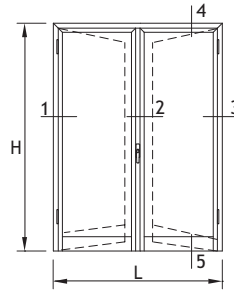

ACESSÓRIOS ACCESSORIES   ACCESSOIRES		
CÓDIGO CODE	DESIGNAÇÃO DESIGNATION   DÉSIGNATION	QUANTIDADE QUANTITY   QUANTITÉ
204801	ESQUADRO PS E. G.   BLOCKING BRACKET   ÉQUERRE	6
202010	DOB. MECHANICA 1145/60   HINGE   PAUMELLE	4
223100	KIT DOB. MECHANICA 1145/705   HINGE KIT   KIT P/PAUMELLE	4
201611	FECHO ANTI-ARROMB. 1459.3   ANTI-BREAK-IN LOCKER   SERRURE ANTI-EFFRACTION	4
207400	CILINDRO BSK 35x35   CYLINDER LOCK   CYLINDRE DE SERRURE	1
220190	ESPELHO 874.801   CYLINDER BACK PLATE   COUVERCLE DE CYLINDRE	2
201010	FECH. 3 PONTOS U 7799x35   3 POINTS LOCKER   SERRURE DE 3 POINTS	1
280004	TESTA FECHADURA PS Nº.1   STRICKING PLATE   GÂCHE	1
280005	TESTA FECHADURA PS Nº.2   STRICKING PLATE   GÂCHE	2
200747	PUXADOR DUPLO 874.31   DOUBLE HANDLE   POIGNÉE DOUBLE	1
202403	CONTRA FECHO DUPLO 1414.5   COUNTER-LOCK   CONTRE-FERMETURE	1
202407	CONTRA FECHO INFERIOR 1408.1   COUNTER-LOCK   CONTRE-FERMETURE	1
225001	PASSADOR PEQUENO 1541.10   LEAF LOCKER   FERMETURE POUR VANTAIL	2
207008-Esq 207007-Dir	TAMPA INVERSOR PS (Esq ou Dir)   END-CAP (Lef or Right)   EMBOUTE (Gauche ou Droite)	1
210154	GOTEIRA 1875   DRIP   GOUTIÈRE	2
218194	CALÇOS P/VIDRO EURO 2000   GLAZING SHIM   CALE P/VITRAGE	Opção   Option   Option

VEDANTES SEALANTS   JOINTS		
CÓDIGO CODE	DESIGNAÇÃO DESIGNATION   DÉSIGNATION	QUANTIDADE QUANTITY   QUANTITÉ
208114	VD 2008	2L+6H
208350	VD 2003	2L+4H
VARIÁVEL VARIABLE	JUNTA INTERIOR   GLAZING WEDGE GASKET   JOINT INTÉRIEUR	2L+4H
208593	PELÚCIA 7x12 STOP-FIN   PLUSH   JOINT BROSSE (SA 25)	L

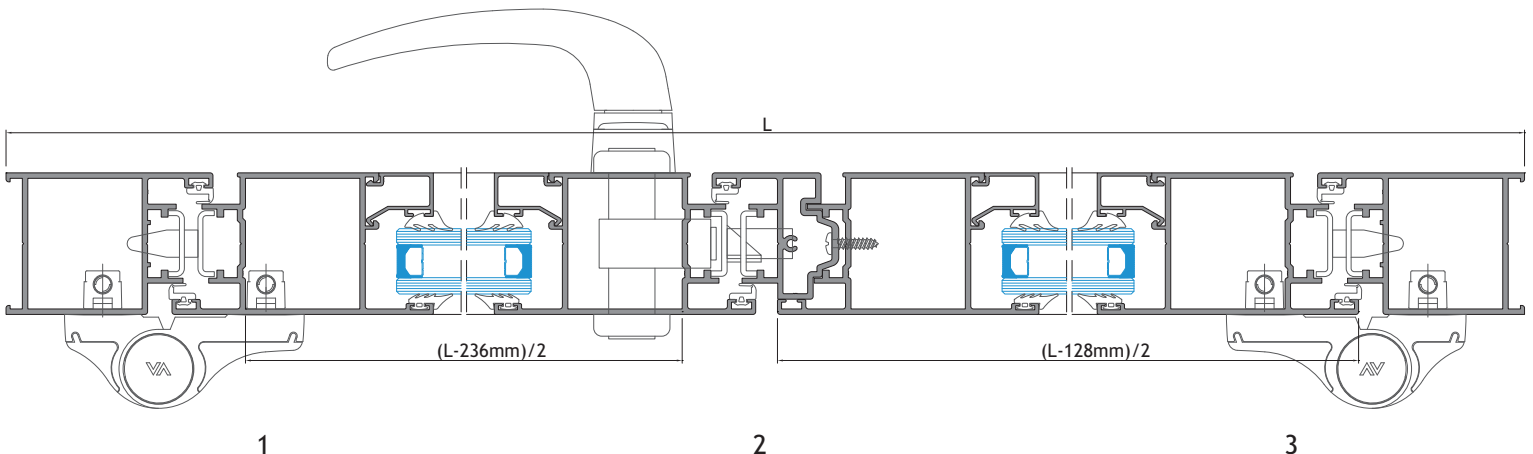

S/ESC.



## PORTA DE VAI-DEM DE 2 FOLHAS

2 LEAVES SWING DOOR

PORTE VA-ET-VIEN 2 VANTAUX

PERFIS PROFILES   PROFILS				
REFERÊNCIA REFERENCE RÉFÉRENCE	CORTE HORIZONTAL HORIZONTAL DETAIL DÉTAIL HORIZONTAL	CORTE VERTICAL VERTICAL DETAIL DÉTAIL VERTICALE	QUANTIDADE QUANTITY QUANTITÉ	CORTE CUT COUPÉ
PS 25	L	H	1+2	
PS 25	(L-165)/2	H-87	2+4	
PS 52	(L-367)/2	-	2	
SA 25	(L-231)/2	-	2	
KP 40	L	H	1+2	
Opção Option	-	-	4+4	

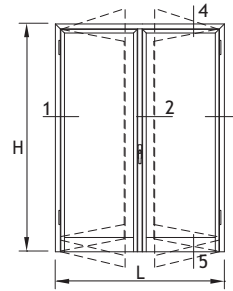

ACESSÓRIOS ACCESSORIES   ACCESSOIRES		
CÓDIGO CODE	DESIGNAÇÃO DESIGNATION   DÉSIGNATION	QUANTIDADE QUANTITY   QUANTITÉ
204002	ESQUADRO PS 25 E. G.   BLOCKING BRACKET   ÉQUERRE	6
228071	MOLA DE CHÃO BTS 75V   FLOOR SPRING   PIVOT À FREIN	1
227111	PIVOT SUPERIOR VAI-DEM 8062   UPPER PIVOT HINGE   PIVOT SUPÉRIEUR	1
210104	BRAÇO INFERIOR VAI-DEM 8021   LOWER PIVOT HINGE   PIVOT INFÉRIEUR	1
207400	CILINDRO BSK 35x35   CYLINDER LOCK   CYLINDRE DE SERRURE	1
220190	ESPELHO 874.801   CYLINDER BACK PLATE   COUVERCLE DE CYLINDRE	2
201612	FECH. 3 PONTOS VAI-DEM U7799x30   3 POINTS LOCKER   SERRURE DE 3 POINTS	1
280004	TESTA FECHADURA PS Nº.1   STRICKING PLATE   GÂCHE	1
280005	TESTA FECHADURA PS Nº.2   STRICKING PLATE   GÂCHE	2
200747	PUXADOR DUPLO 874.31   DOUBLE HANDLE   POIGNÉE DOUBLE	1
202403	CONTRA-FECHO DUPLO SUP. 1414.5   COUNTER-LOCK   CONTRE-FERMETURE	1
202407	CONTRA-FECHO INF. 1408.1   COUNTER-LOCK   CONTRE-FERMETURE	1
225001	PASSADOR PEQUENO 1541.10   LEAF LOCKER   FERMETURE	2
210154	GOTEIRA 1875   DRIP   GOÜTTIÈRE	2
218194	CALÇOS P/VIDRO EURO 2000   GLAZING SHIM   CALE P/VITRAGE	Opção   Option   Option

VEDANTES SEALANTS   JOINTS		
CÓDIGO CODE	DESIGNAÇÃO DESIGNATION   DÉSIGNATION	QUANTIDADE QUANTITY   QUANTITÉ
208350	VD 2003	2L+4H
VARIÁVEL VARIABLE	JUNTA INTERIOR   GLAZING WEDGE GASKET   JOINT INTÉRIEUR	2L+4H
208460	PELÚCIA 7x7 STOP-FIN   PLUSH   JOINT BROUSSE (PS 25)	4L+12H
208593	PELÚCIA 7x12 STOP-FIN   PLUSH   JOINT BROUSSE (SA 25)	L

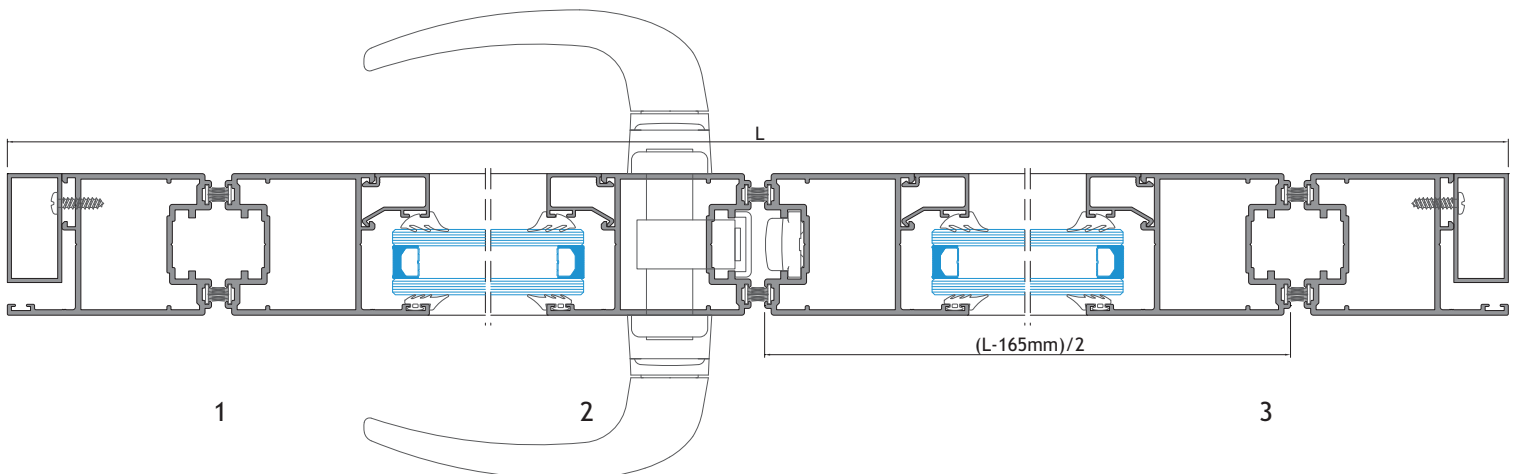
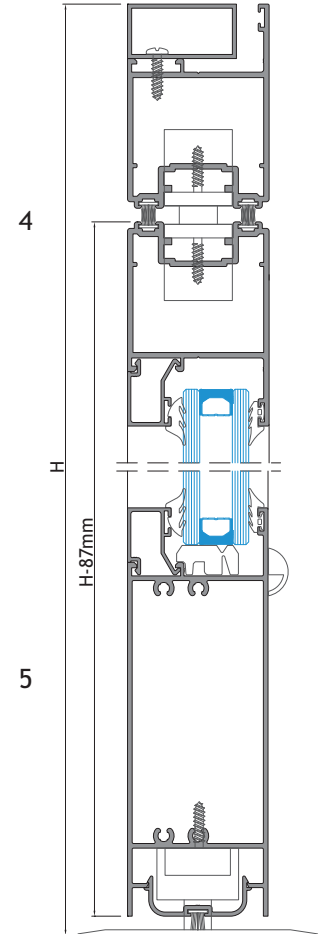

S/ESC.

**PORTA DE 1 FOLHA - ABERTURA PARA EXTERIOR COM BARRA ANTI-PÂNICO**

LEAF DOOR OUTWARD OPENING WITH ANTI-PANIC BAR

PORTE 1 VANTAIL - OUVERTURE VERS L'EXTÉRIEUR AVEC BARRE ANTI-PANIQUE

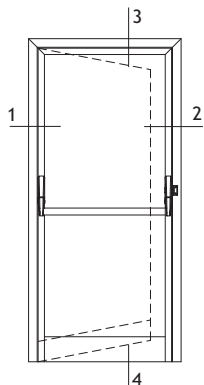

ALTERNATIVA - COM ANTI-ENTALAMENTO  
 ALTERNATIVE - WITH ANTI-FINGER TRAP SYSTEM  
 ALTERNATIVE - AVEC SYSTÈME ANTI-PINCE DOIGTS

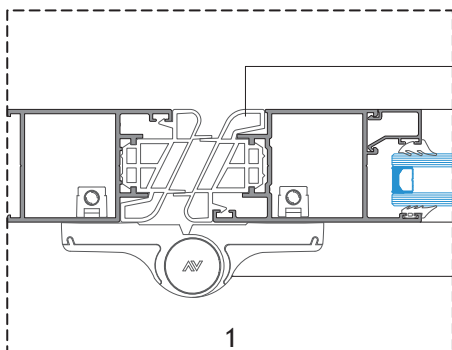

VD 2053

DOBRADIÇA MECHANICA 1145/93SM  
 HINGE MECHANICA 1145/93SM  
 PAUMELLE MECHANICA 1145/93SM

1

PS 07

VD 2008

PS 12

3

JUNTA DE CUNHA  
 GLAZING WEDGE GASKET  
 JOINT INTÉRIEUR

BARRA ANTI-PÂNICO  
 ANTI-PANIC BAR  
 BARRE ANTI-PANIQUE

JUNTA 2003  
 GLAZING GASKET 2003  
 JOINT EXTERIEUR 2003

4

BITE  
 GLAZING BEAD  
 PARCLOSE  
 CALÇO  
 SHIM  
 CALE  
 GOTEIRA  
 DRIP  
 GOUTTIÈRE

PS 52

DOBRADIÇA 1147  
 HINGE 1147  
 PAUMELLE 1147

SA 25

PELÚCIA 7x12 S-F  
 PLUSH  
 JOINT BRASSE

MOLA DE CHÃO BTS 75V  
 FLOOR SPRING  
 PIVOT À FREIN BTS 75V

BARRA ANTI-PÂNICO  
 ANTI-PANIC BAR  
 BARRE ANTI-PANIQUE

PS 07

PS 12

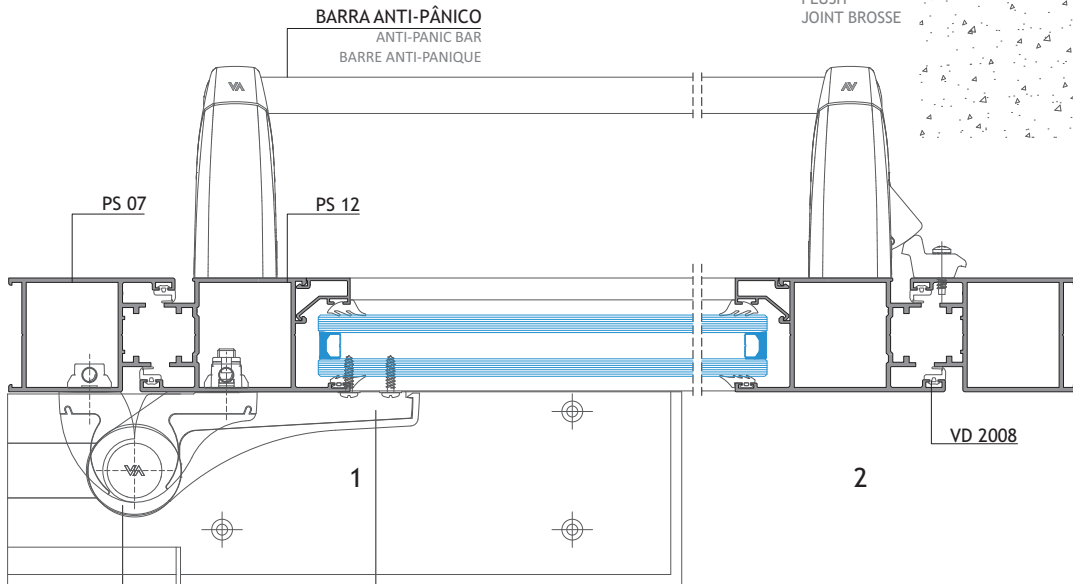

VD 2008

1

2

DOBRADIÇA 1146.1/62.5  
 HINGE 1146.1/62.5  
 PAUMELLE 1146.1/62.5

DOBRADIÇA 1147  
 HINGE 1147  
 PAUMELLE 1147

MOLA DE CHÃO BTS 75V  
 FLOOR SPRING  
 PIVOT À FREIN BTS 75V



S/ESC.

**PORTA DE 2 FOLHAS COM FIXOS E JANELA BASULANTE - ABERTURA PARA INTERIOR**

3 LEAVES DOOR WITH FIXED PANELS AND 1 HOPPER WINDOW - INWARD OPENING

PORTE 3 VANTAUX AVEC PANNEAUX FIXES ET 1 FENÊTRE À SOUFFLET- OUVERTURE VERS L'INTÉRIEUR

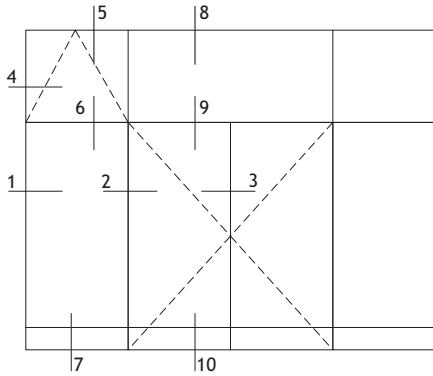

ABERTURA PARA EXTERIOR  
OUTWARD OPENING  
OUVERTURE VERS L'EXTÉRIEUR

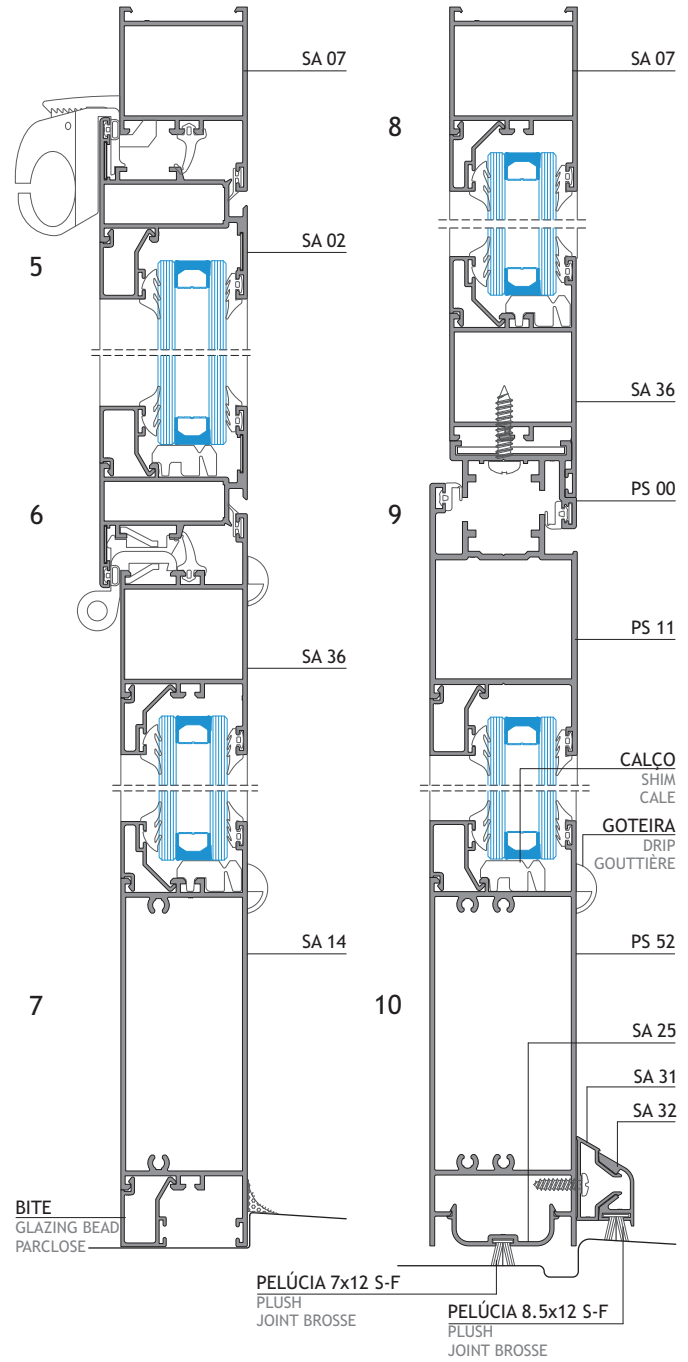
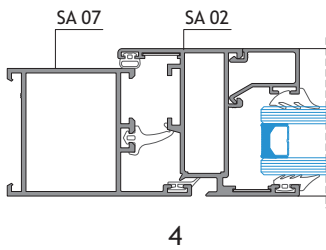
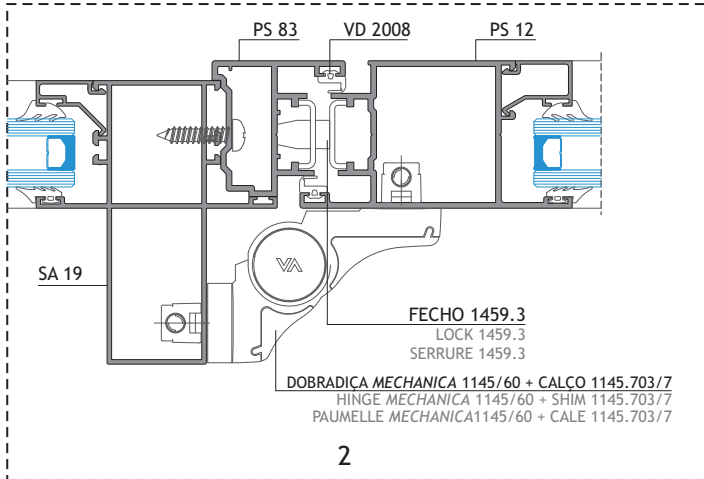

DOBRADIÇA MECHANICA 1145/79 + CALÇO 1145.703/7  
HINGE MECHANICA 1145/79 + SHIM 1145.703/7  
PAUMELLE MECHANICA 1145/79 + CALE 1145.703/7

PUXADOR 874.31  
HANDLE 874.31  
POIGNÉE 874.31

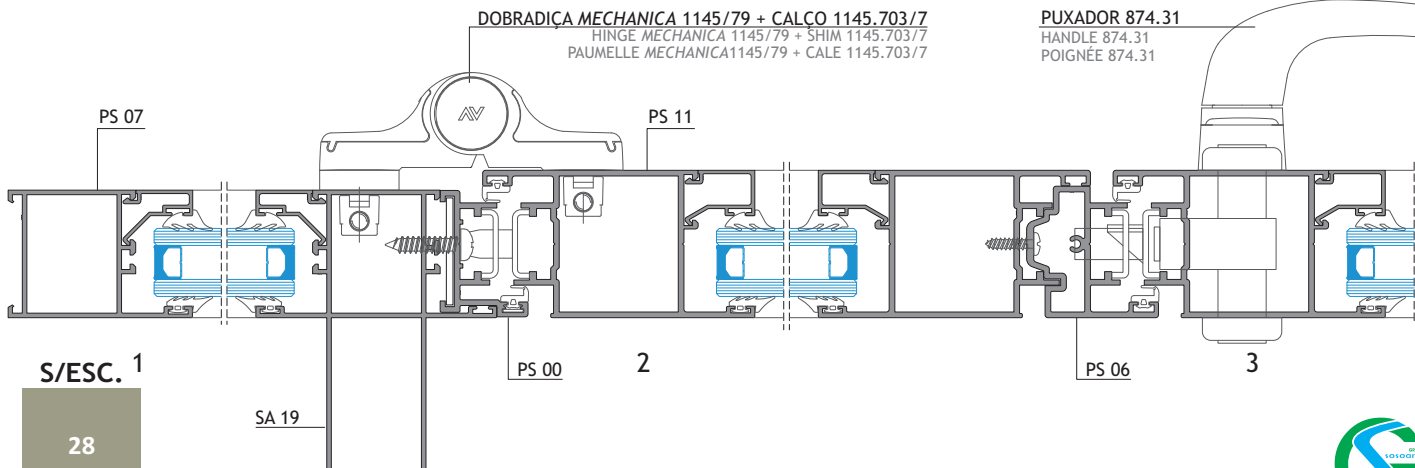





**SISTEMAS**  
**EURO 2000**®  
PERFIS DE ALUMÍNIO E VIDROS PARA ARQUITECTURA

### **ALFA SUL**

EN Lisboa-Sintra Km 14  
2725-397 Mem Martins  
T +351 219 265 090 | F +351 219 265 098  
E [alfa.sul@sosoares.pt](mailto:alfa.sul@sosoares.pt)

### **ALULIDER**

Pavilhão Industrial H - Plataforma 13D  
Zona Franca Industrial  
9200-047 Caniçal - Madeira  
T +351 291 960 494 | F +351 291 960 497  
E [alulider@sosoares.pt](mailto:alulider@sosoares.pt)

### **METALFER**

Travessa do Bolegão, 146  
Apartado 1  
3754-904 Fermentelos  
T +351 234 729 740 | F +351 234 729 741  
E [metalfer@sosoares.pt](mailto:metalfer@sosoares.pt)

### **PERFIS OEIRAS**

Rua da Colónia - Quinta da Cardosa  
Apartado 214 - Abrunheira  
2711-952 Sintra  
T +351 219 156 660 | F +351 219 156 661  
E [perfis.oeiras@sosoares.pt](mailto:perfis.oeiras@sosoares.pt)

### **PORTALEX**

Estrada de S. Marcos, 23  
2735-521 Cacém  
T +351 210 412 500 | F +351 210 412 507  
E [comercial@portalex.eu](mailto:comercial@portalex.eu)

### **SOSOARES**

Rua do Campo Alegre, 474  
4150-170 Porto  
T +351 226 096 709 | F +351 226 005 642  
E [comercial@sosoares.pt](mailto:comercial@sosoares.pt)



[www.sosoares.pt](http://www.sosoares.pt)



[www.portalex.eu](http://www.portalex.eu)