



sistema de portões de batente e de correr

swing and sliding gates system

système de portails à battante et coulissantes



SISTEMAS
EURO 2000[®]
PERFIS DE ALUMÍNIO E VIDROS PARA ARQUITECTURA

3

Listagem de perfis

Profiles list
Liste des profilés

13

Acessórios

Accessories
Accessoires

27

Pormenores de montagem

Assembly details
Détails d'assemblage



Características do Sistema

System features

Caractéristiques du système



A série PA+ surge como um aperfeiçoamento dos sistemas tradicionais de portões de correr e de batente. Resulta da necessidade de aligeirar o processo de fabricação, no sentido de otimizar os tempos de execução, de modo a oferecer uma melhor e mais célere resposta às novas exigências e modelos de construção.

The PA + series comes as an improvement of the traditional systems of sliding and jamb gates. It results from the need to lighten the manufacturing process, towards execution times optimization, in order to offer a better and faster response to new requirements and construction models.

La série PA + vient comme une amélioration des systèmes traditionnels de portail coulissants et de battante. De la nécessité de rationaliser le processus de fabrication afin d'optimiser les temps d'exécution afin d'offrir une réponse mieux et plus rapide aux nouvelles exigences et modèles de construction.

Batente Jamb Ouvrant		Correr Sliding Coulissant
Dimensões:	Aro Fixo:	52mm
Dimensions	Fixed frame:	
Dimension	Cadre dormant:	
	Aro Móvel:	40mm
	Mobile frame:	
	Cadre ouvrant:	
Cortes:	45° 90°	
Cuts		
Coupes		
Unições:	Aparafusadas	
Unions	Screwed	
Unions	Vissée	
Enchimento:	Lâminas Vidro	
Filling	Louvres Glass	
Remplissage	Lames Verre	
Dimensões máximas:	Portão de 1 folha: 2.00m	Portão de 1 folha: 4.00x2.00m (LxA)
Maximum dimensions:	1 leaf gate: 2.00m	1 leaf gate: 4.00x2.00m (LxH)
Dimensions maximales:	Portail 1 vantail: 2.00m	Portail 1 vantail: 4.00x2.00m (LxH)
	Portão de 2 folhas: 4.00m	
	2 leaves gate portail 2 vantaux	
Aberturas:	Manual Motorizada	
Openings	Manual Motorized	
Ouvertures	Manuelle Motorisé	
Acabamentos:	Lacados Anodizados	
Finishes	Powder coating Anodizing	
Finitions	Laqué Anodisé	



Licença nº. 1406 - Metalferr
Licença nº. 1411 - Alfa Sul



Licença nº. 809 - Sosoares
Licença nº. 817 - Portalex

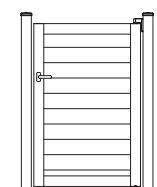

Portão 1 folha
Gate 1 leaf
Portail 1 vantail

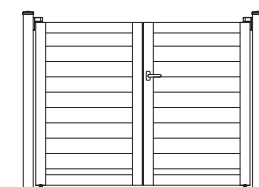

Portão 2 folhas
Gate 2 leaves
Portail 2 vantaux

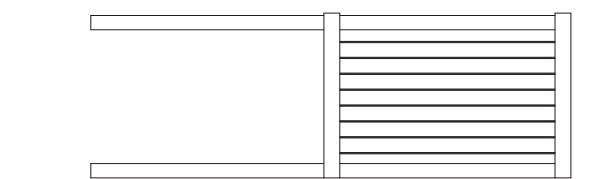

Portão correr 1 folha
Sliding gate 1 leaf
Portail coulissante 1 vantail



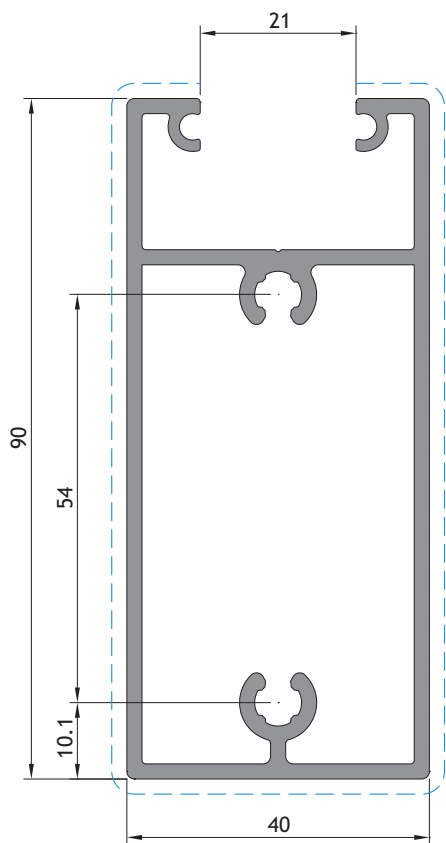

PA 34

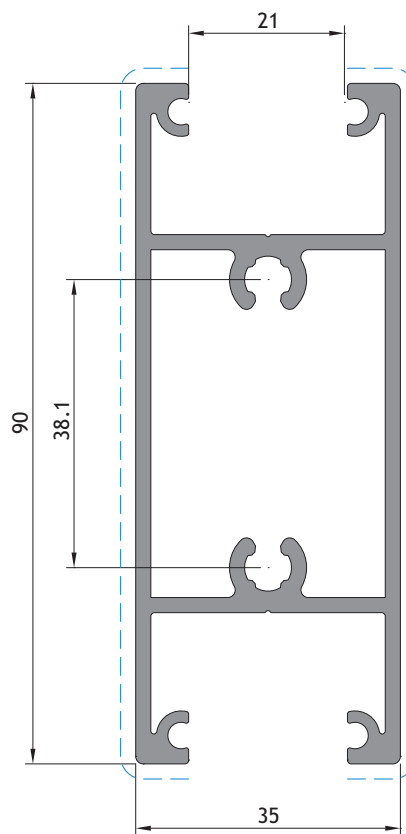

PA 36

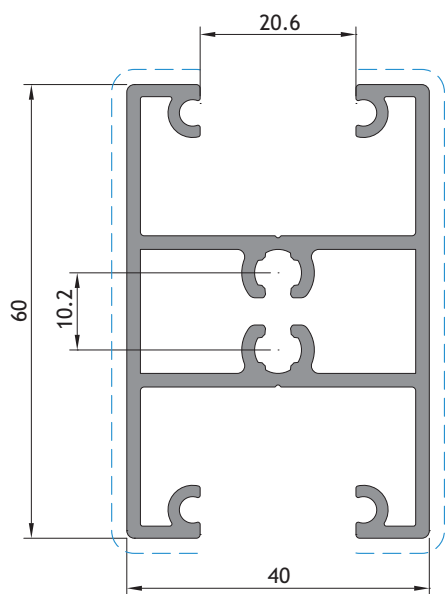

PA 35

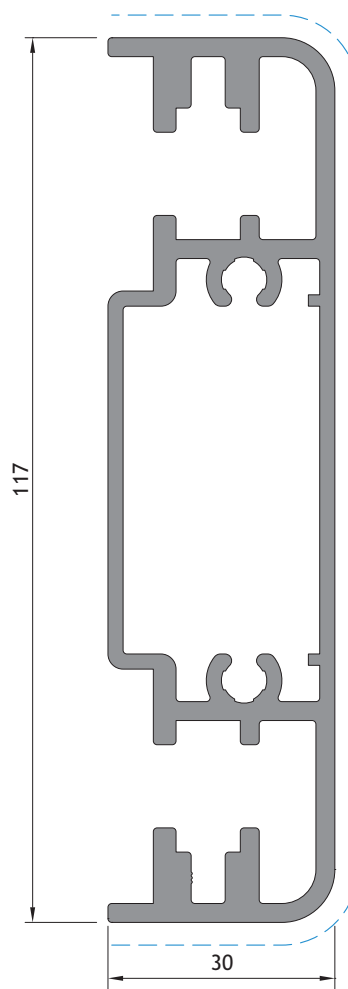

PA 26

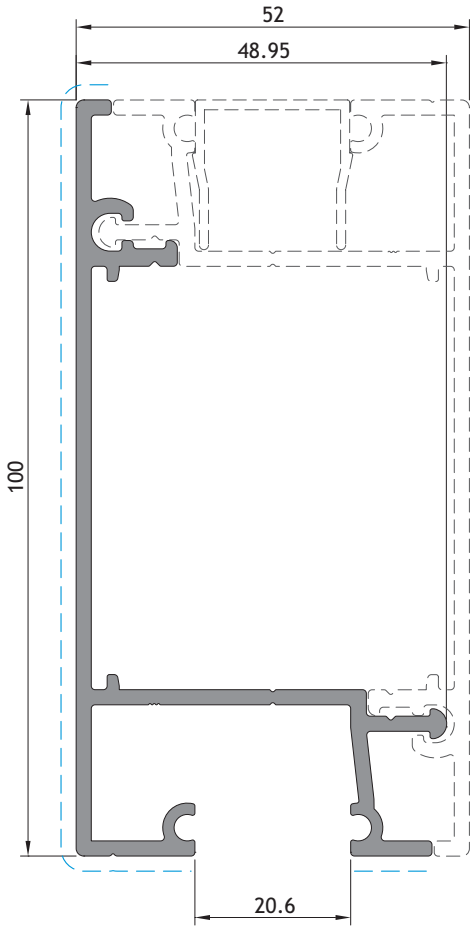

PA 61

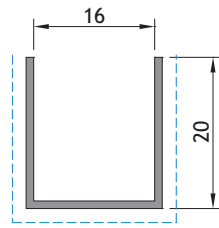

KU 19

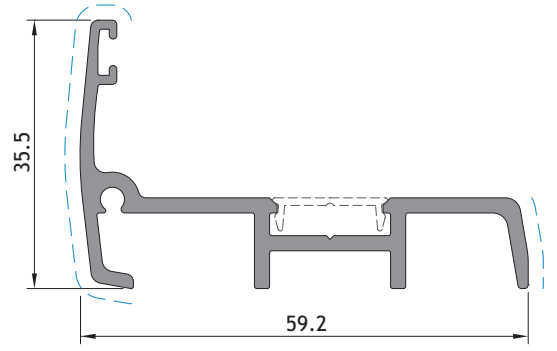

PA 30

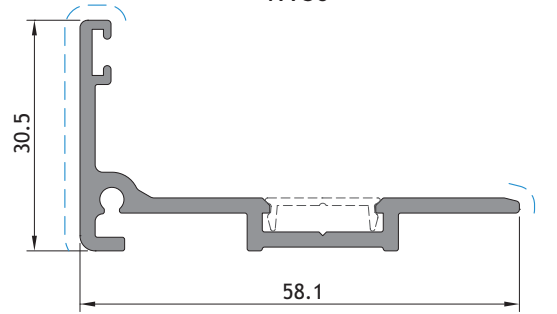

PA 37

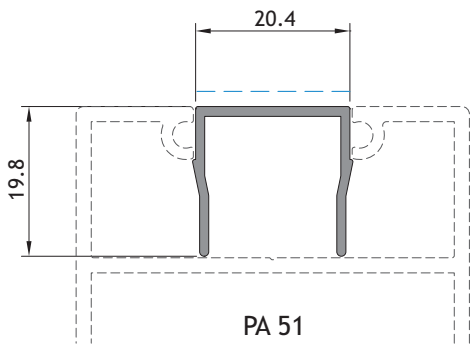

PA 51

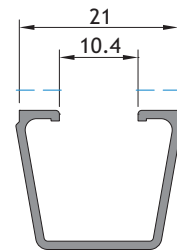

SP 24

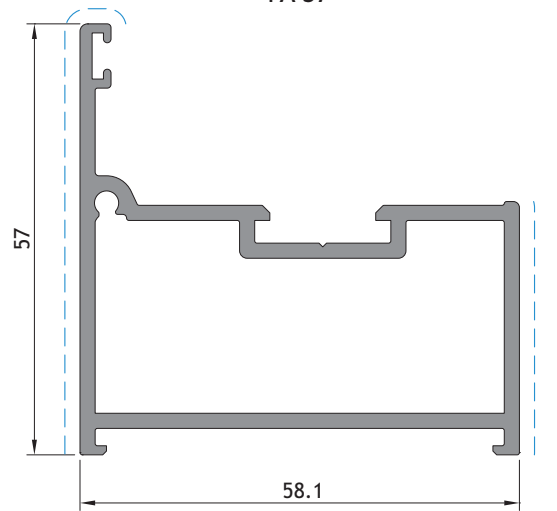

PA 38

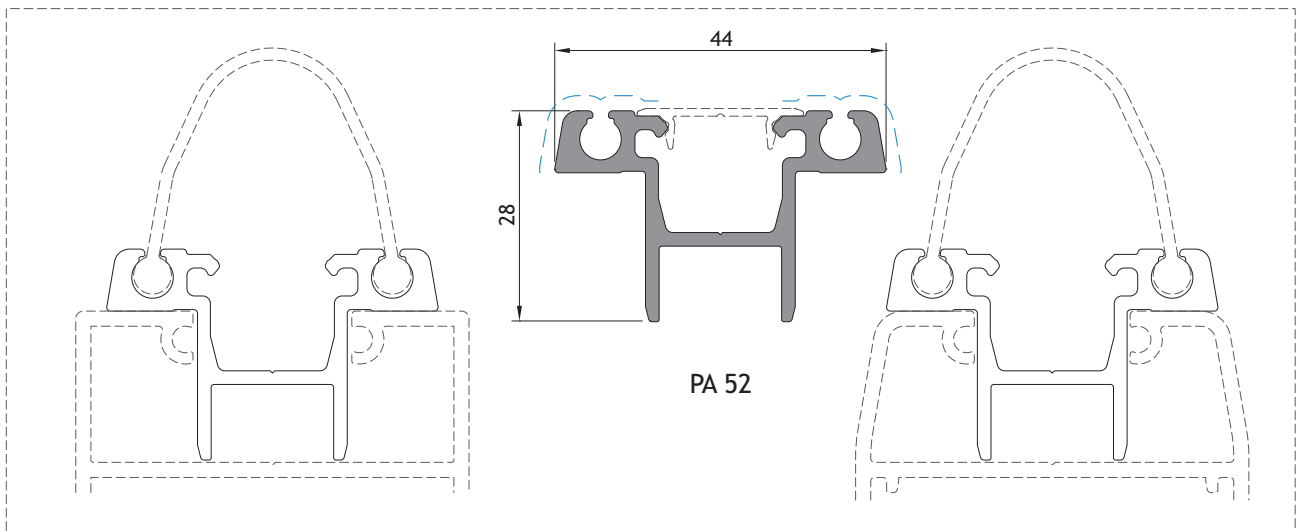

PA 52

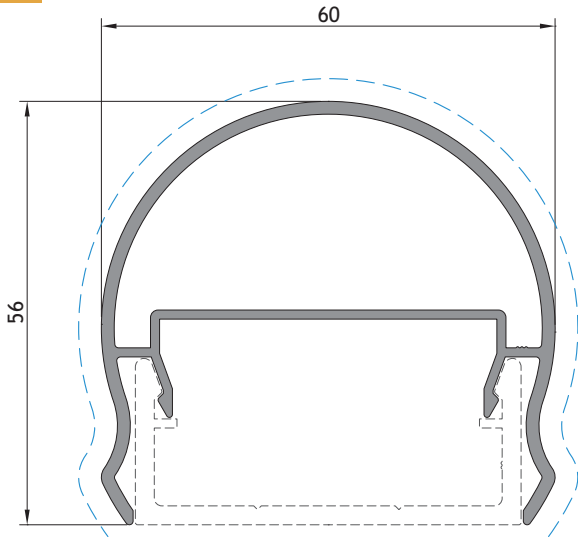

PA 14

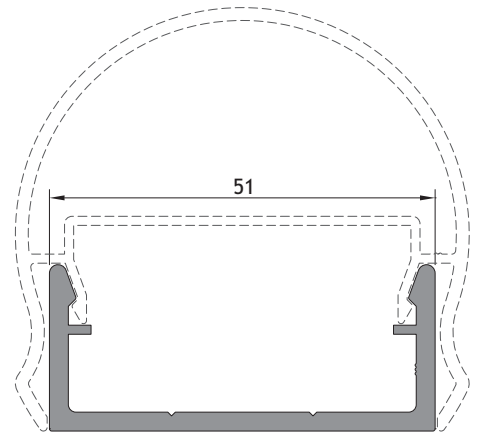

PA 13

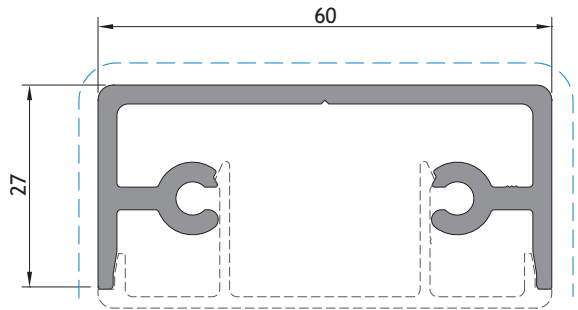

PA 29

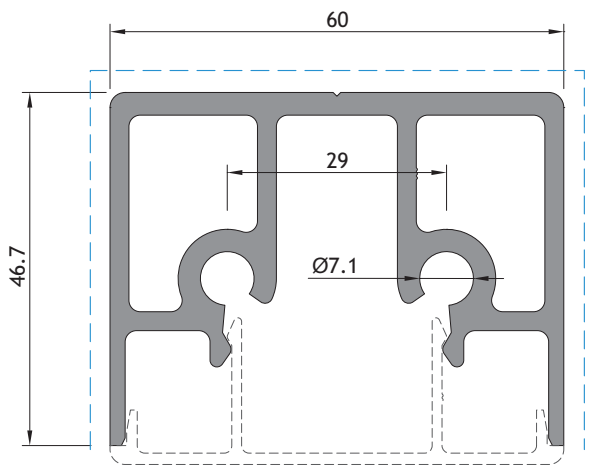

PA 08

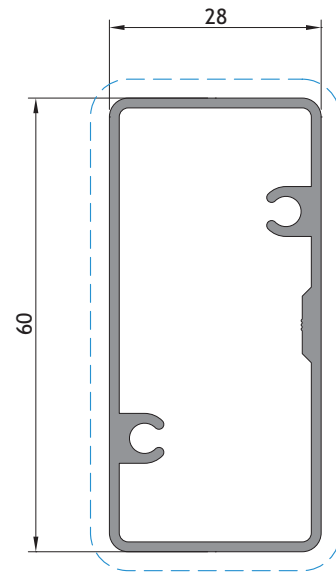

PA 18

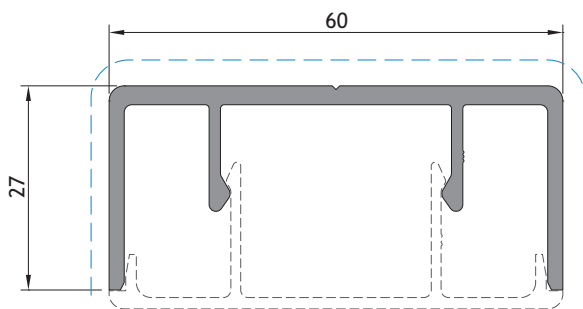

PA 09

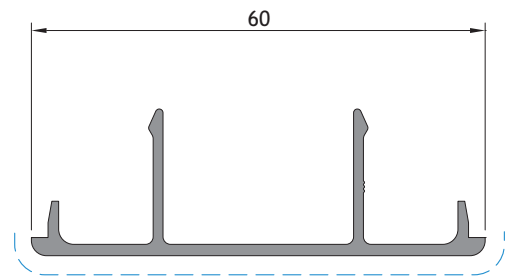

PA 10

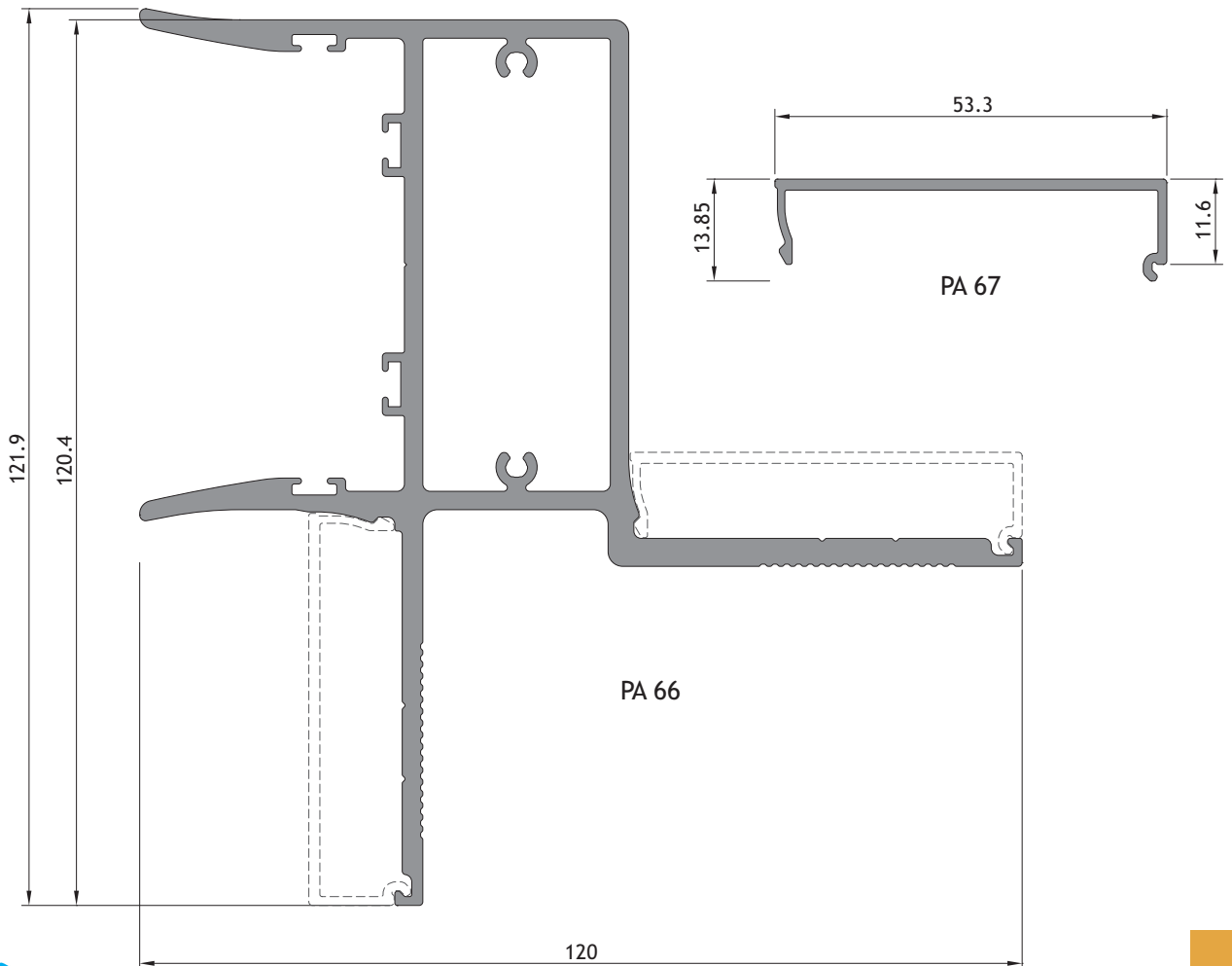
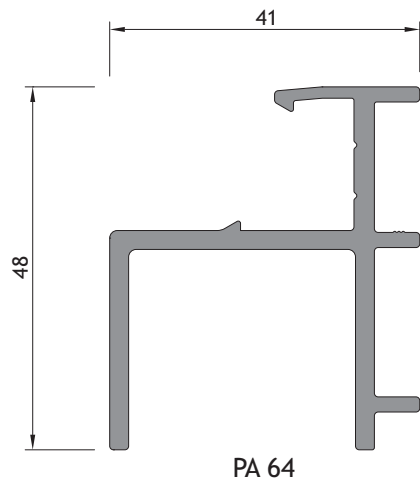
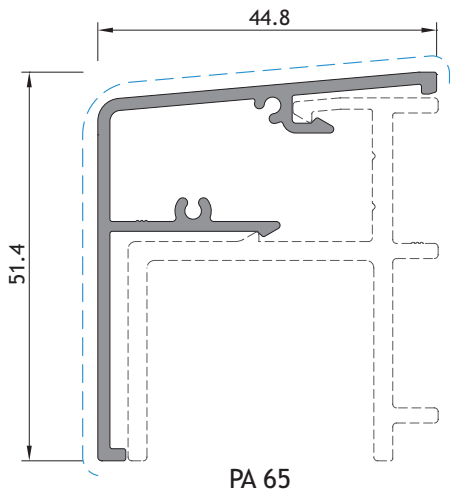
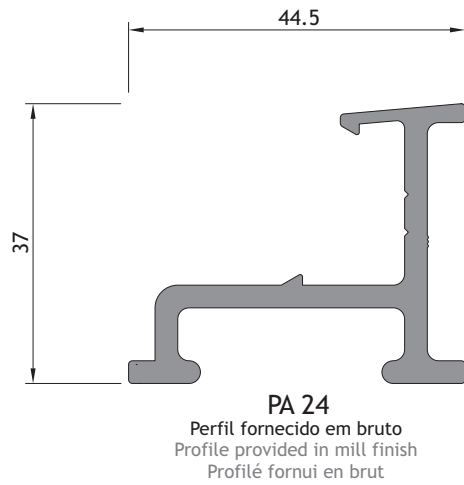
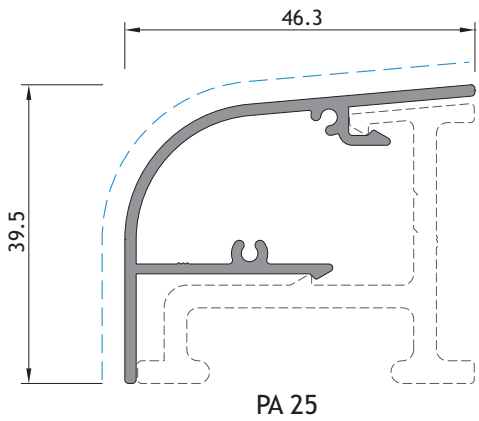

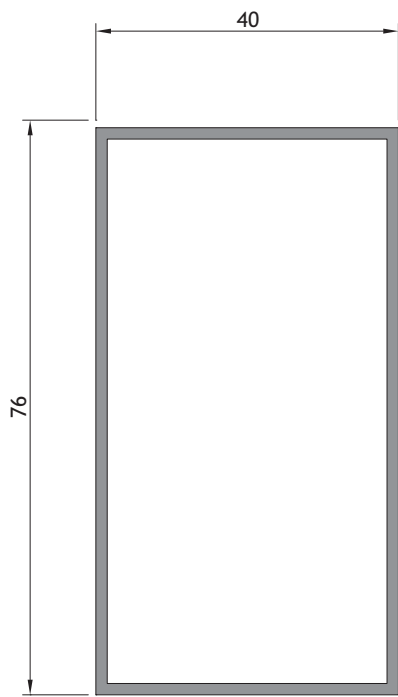

KP 75

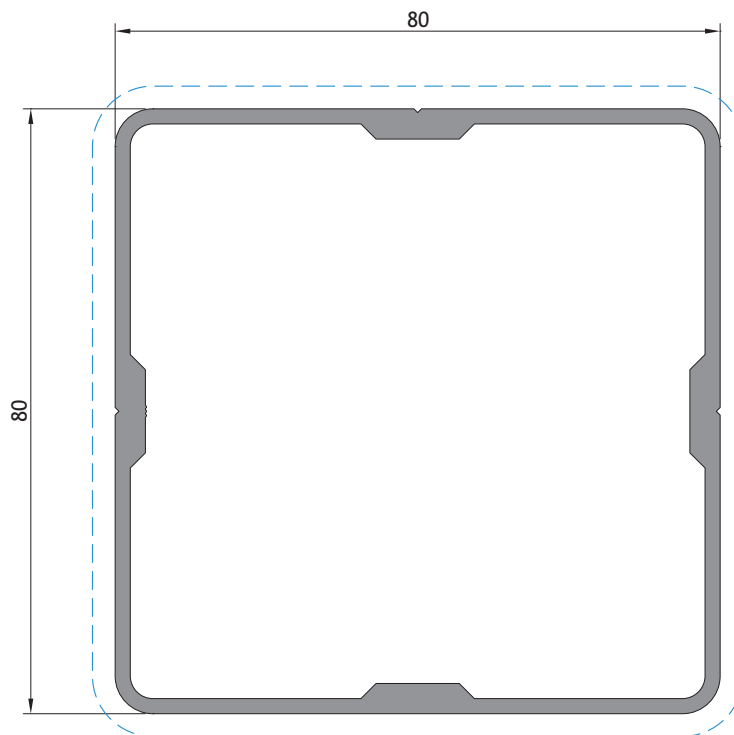

PA 03

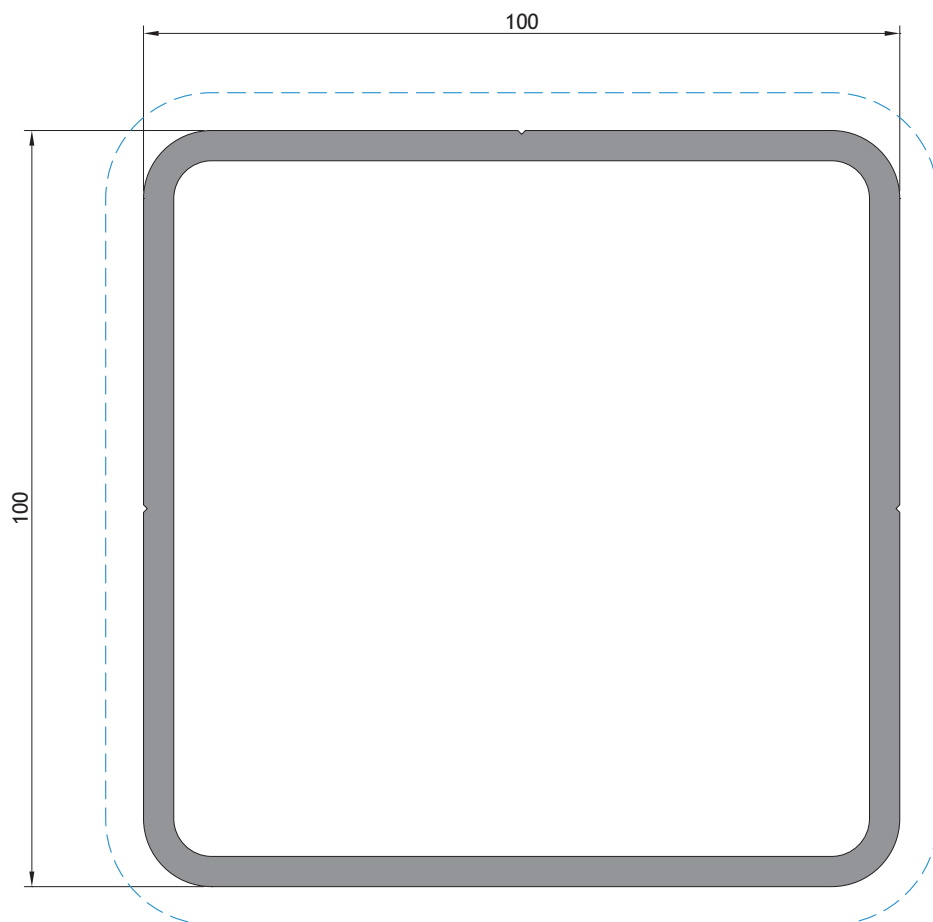

PA 11

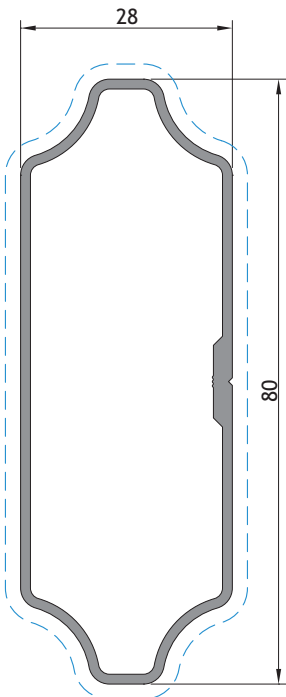

PA 02

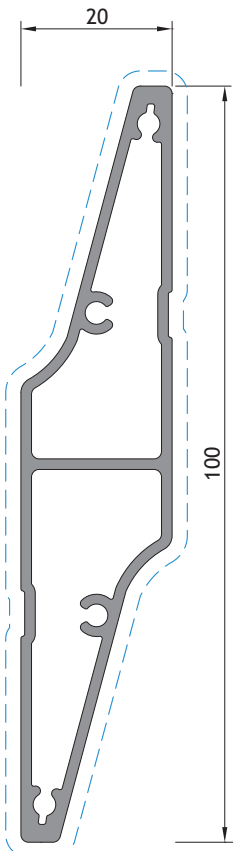

PA 50

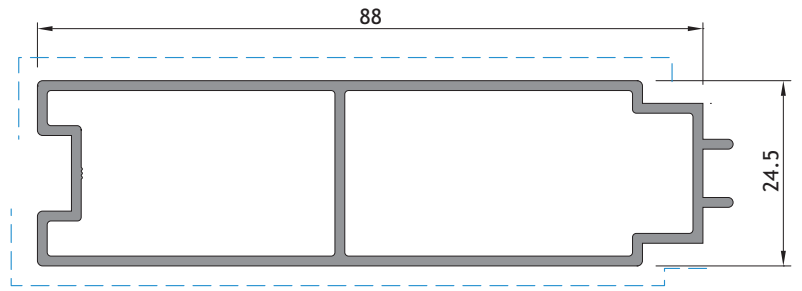

PB 09

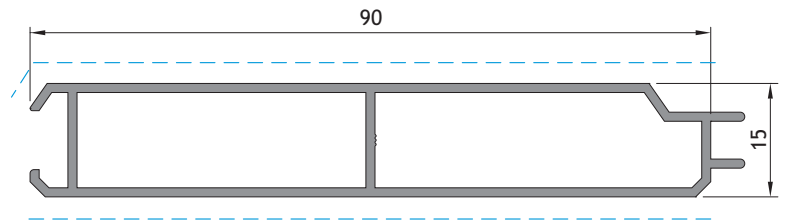

PA 16

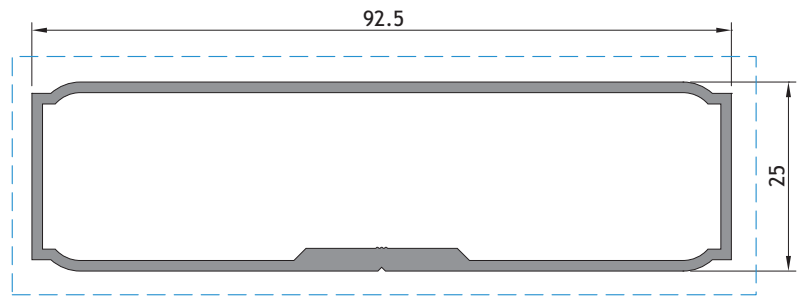

PA 05

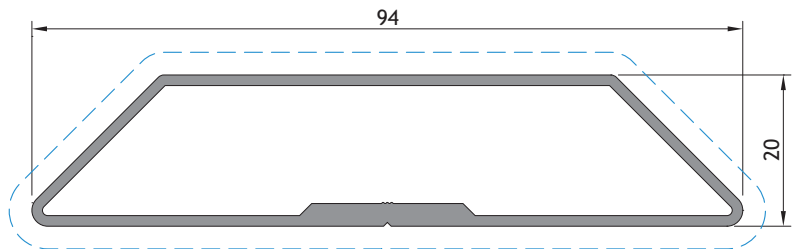

PA 06

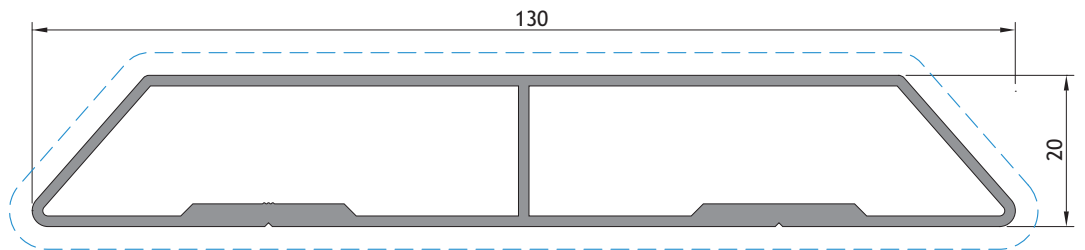

PA 12

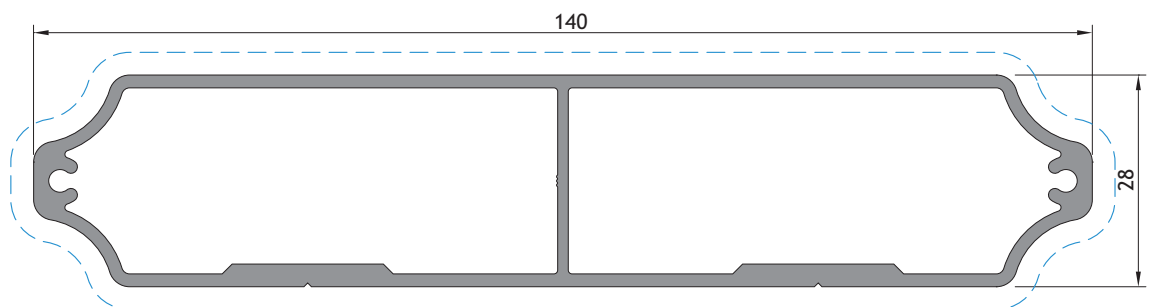

PA 17

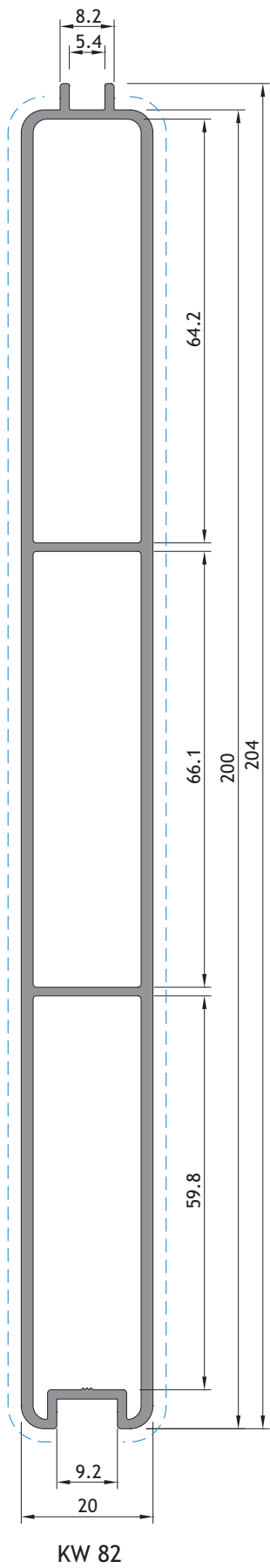

KW 82

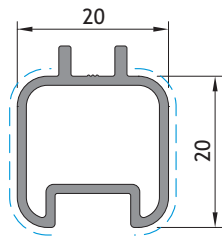

KW 03

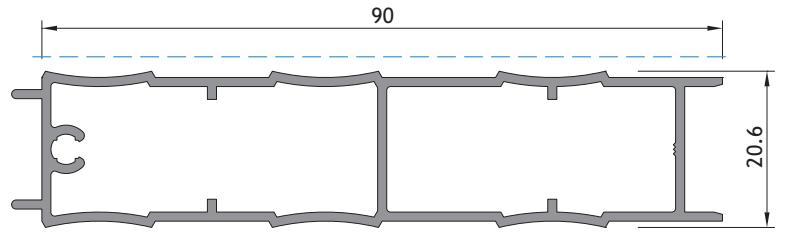

KW 12

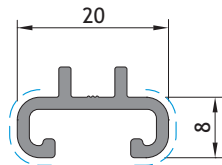

KW 23

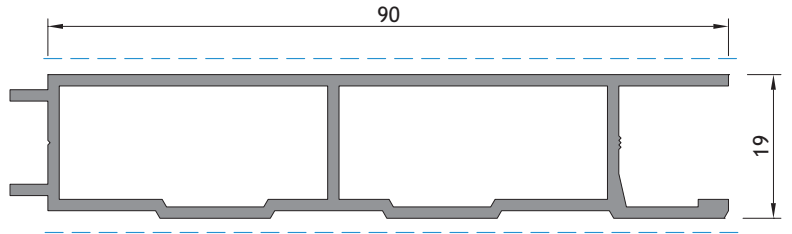

KW 52

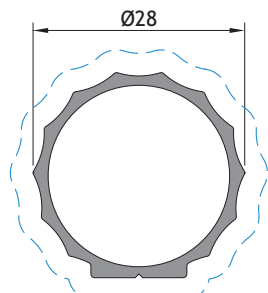

PA 04

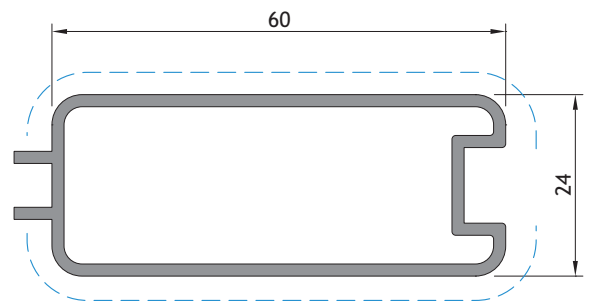

KW 04

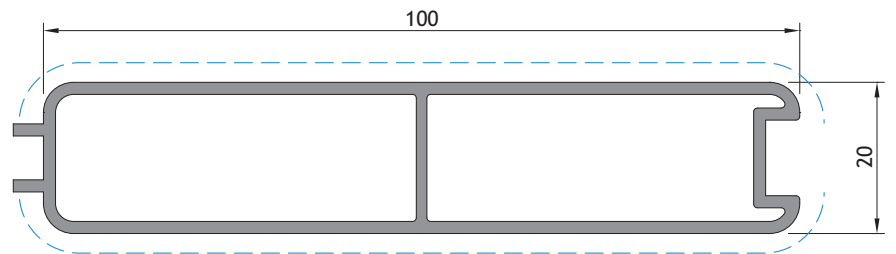

KW 92

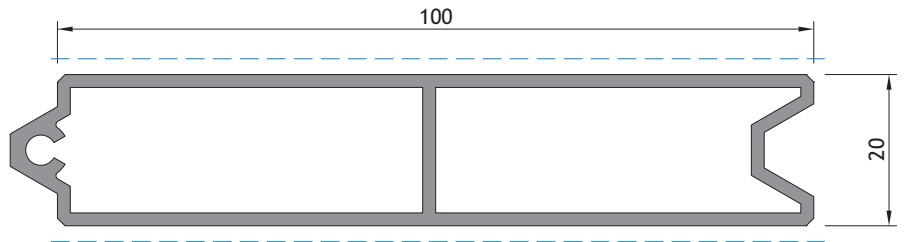

KW 42

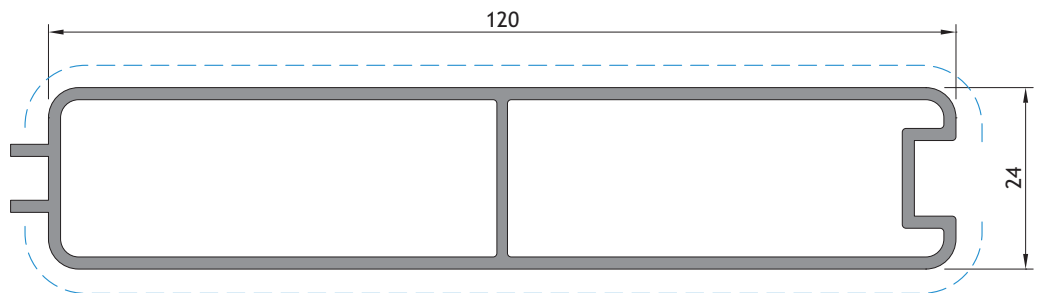

KW 24

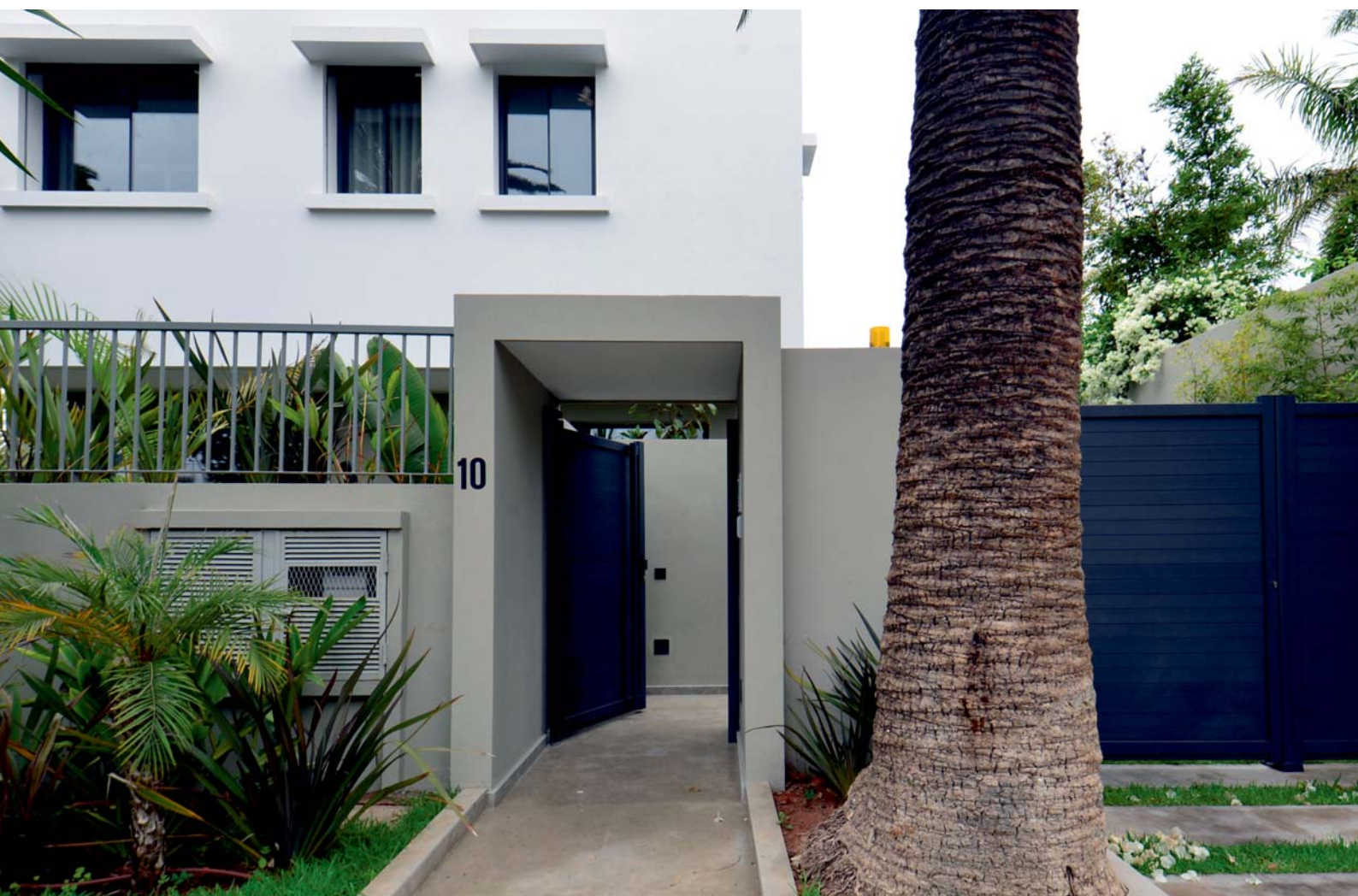

Acessórios

Accessories

Accessoires





2051

Material: EPDM 2 durezas
(Zona de batente: EPDM esponjoso)
Base: EPDM de 70° SHORE
Rolo: 300m(150m+150m)

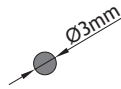

1033

Material: EPDM esponjoso
(Rolo: 200m)

208008
208221

JUNTA DE ESTANQUIDADE 2051
JUNTA VD 1033

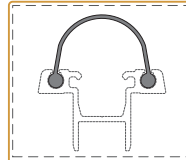

208222

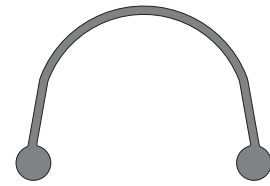

Material: EPDM
(Rolo: 100m)

VEDANTE 2120

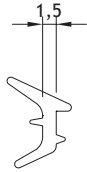

1031
(Rolo: 100m)

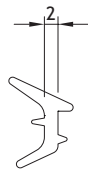

2042

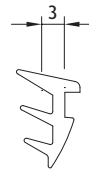

2073



2034



2035



2036



2037

Material: EPDM
Rolo: 200m

208223 JUNTA DE CUNHA 1031
208191 JUNTA DE CUNHA 2042
208195 JUNTA DE CUNHA 2034
208196 JUNTA DE CUNHA 2035

208215 JUNTA DE CUNHA 2036
208904 JUNTA DE CUNHA 2037
208199 JUNTA DE CUNHA 2073

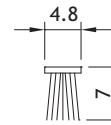

(Rolo: 325m)

208564

VEDANTE PELÚCIA 4.8x7 Cinza

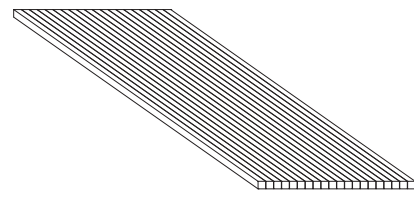

Variável

218132 CALÇO P/VIDRO 99x33x1
218113 CALÇO P/VIDRO 79x40x2
218109 CALÇO P/VIDRO 79x40x3
218111 CALÇO P/VIDRO 79x40x4
218112 CALÇO P/VIDRO 79x49x5

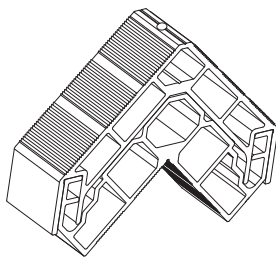

Aplicar com perfil PA 31

204162

ESQUADRO ESPECIAL PA

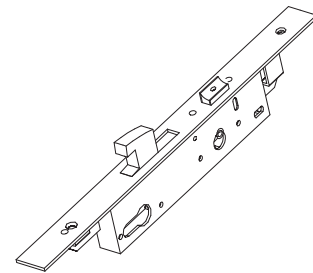

201050

FECHADURA PRUMO 7716x35

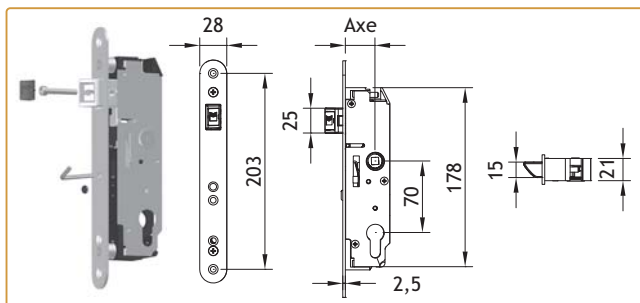

201134

FECHADURA PRUMO PA T40

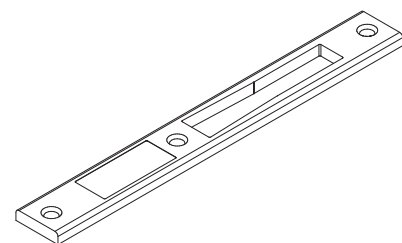

280220

TESTA FECHADURA PRUMO 2000

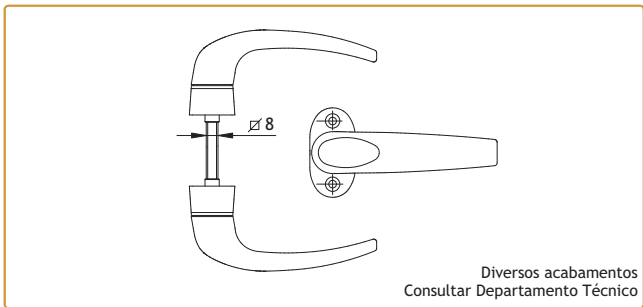

Diversos acabamentos
Consultar Departamento Técnico

200028 PUXADOR DUPLO 874.31

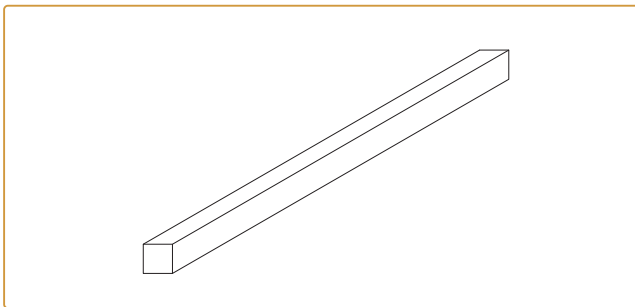

227301 QUADRA AÇO 8mm PARA PUXADOR 874

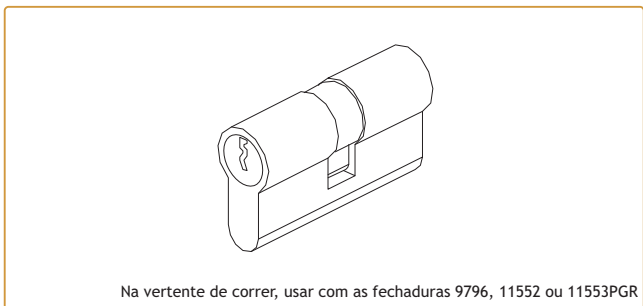

Na vertente de correr, usar com as fechaduras 9796, 11552 ou 11553PGR

230017 SEGREDO 30/30 COM 3 CHAVES



2 Dobradiças = 160Kg
3 Dobradiças = 180Kg

202611 DOBRADIÇA 2 ABAS 1146.1/62.5

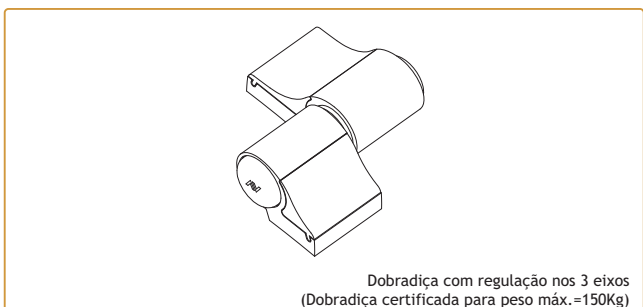

Dobradiça com regulação nos 3 eixos
(Dobradiça certificada para peso máx.=150Kg)

202010 DOBRADIÇA MECANICA 2 ABAS 1145/60
202012 DOBRADIÇA MECANICA 2 ABAS 1145/79
202020 DOBRADIÇA MECANICA 2 ABAS 1145/93SM

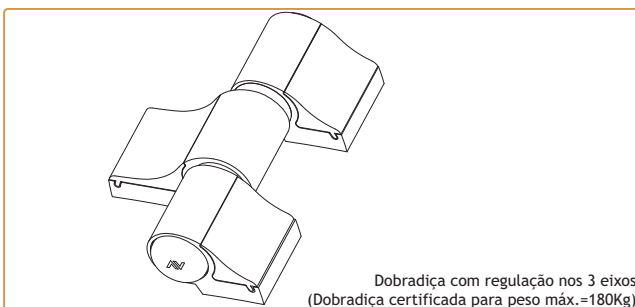

Dobradiça com regulação nos 3 eixos
(Dobradiça certificada para peso máx.=180Kg)

202610 DOBRADIÇA MECANICA 3 ABAS 1145.3/60

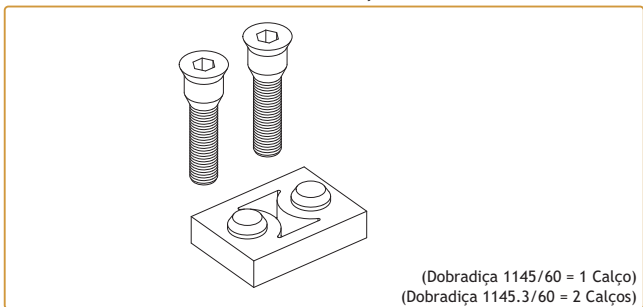

(Dobradiça 1145/60 = 1 Calço)
(Dobradiça 1145.3/60 = 2 Calços)

218170 CALÇO PARA DOBRADIÇA MECANICA 1145.703/7

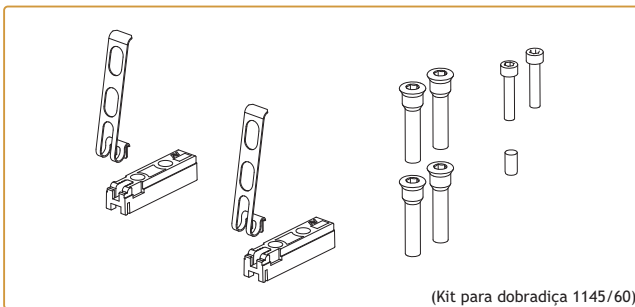

(Kit para dobradiça 1145/60)

223100 KIT DE FIXAÇÃO PARA MECANICA 1145.705

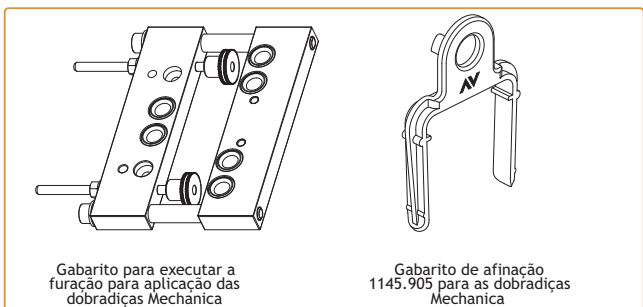

Gabarito para executar a
furação para aplicação das
dobradiças Mecanica

Gabarito de afinación
1145.905 para as dobradiças
Mecanica

211101 GABARITO PARA FURAÇÃO 1145.908

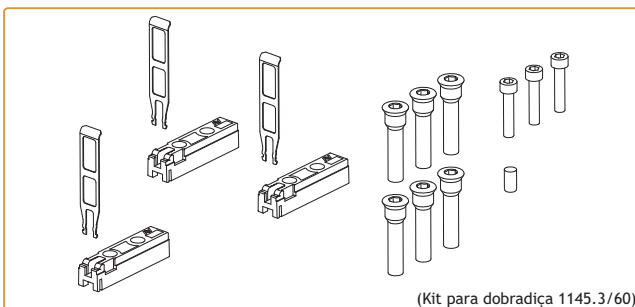

(Kit para dobradiça 1145.3/60)

223020 KIT DE FIXAÇÃO PARA MECANICA 1145.715



202352 DOBRADIÇA PA INOX 100Kg

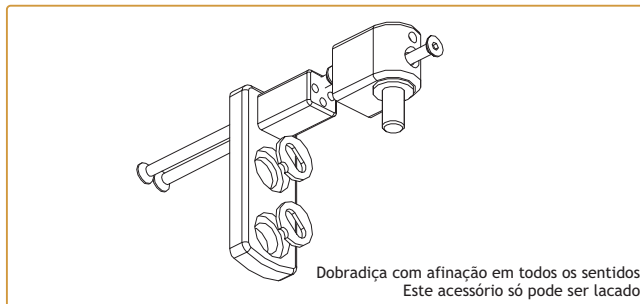

202164 DOBRADIÇA C/REGULAÇÃO PA 24000

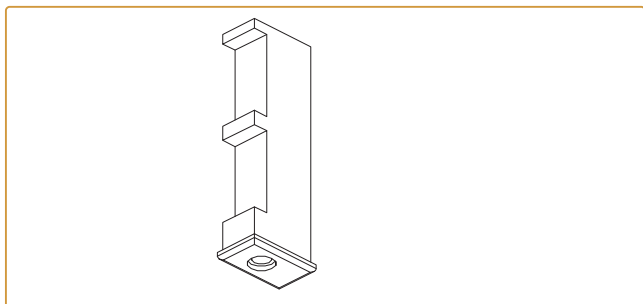

215143 PEÇA PARA DOBRADIÇA PA 17131 (Br./Pr.)

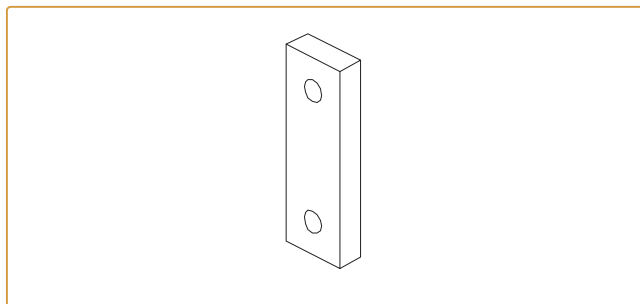

215175 PLACA DE REFORÇO P/DOB. 24000



227124 PIVOT SUPERIOR INOX

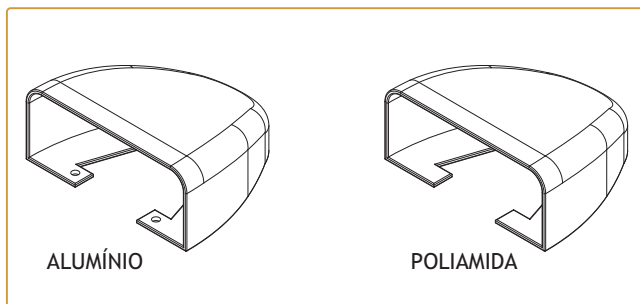

207332 TAMPA EM ALUMÍNIO PARA PIVOT SUPERIOR INOX
207333 TAMPA EM POLIAMIDA PARA PIVOT SUPERIOR INOX



227127 PIVOT SUPERIOR Nº.2 INOX C/CAPA EM POLIAMIDA

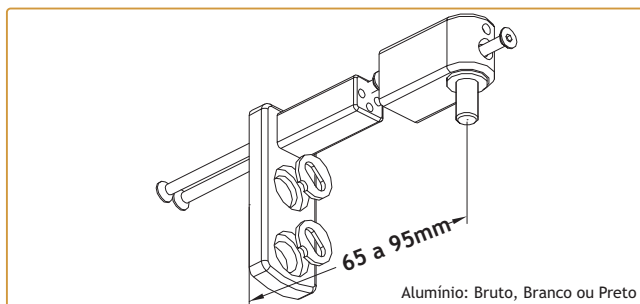

227123 PIVOT SUPERIOR Nº.3 65/95mm ALUMÍNIO
Alumínio: Bruto, Branco ou Preto



210180 ANEL PIVOT Nº.2 INOX (LATÃO)



210181 ANEL PIVOT Nº.3 INOX (POLIAMIDA)

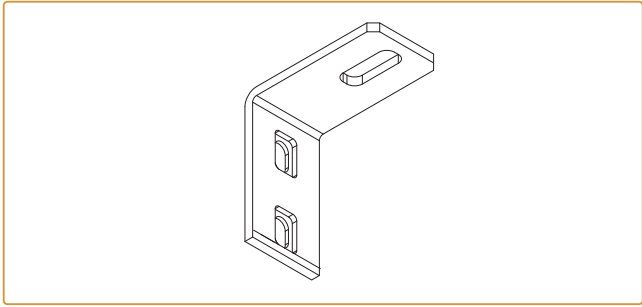

227119
227120

PIVOT SUP./INF. Nº.1 INOX
PIVOT SUP./INF. Nº.1 GALVANIZADO

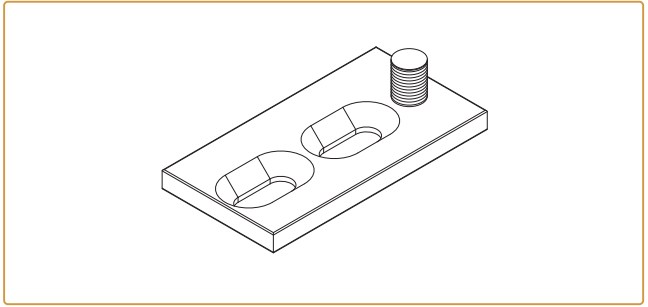

227121
227122

PIVOT INFERIOR Nº.1 INOX
PIVOT INFERIOR Nº.1 GALVANIZADO



227125

PIVOT INFERIOR Nº.2 INOX



227126

PIVOT INFERIOR Nº.3 INOX

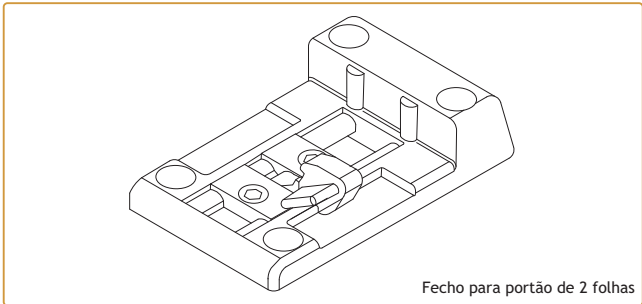

Fecho para portão de 2 folhas

201570

FECHO INFERIOR PVC PARA 2 FOLHAS PA 16201Pr.

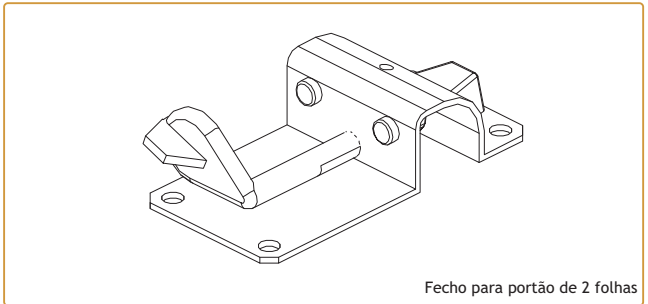

Fecho para portão de 2 folhas

201025

FECHO INFERIOR inox PARA 2 FOLHAS PA 16011

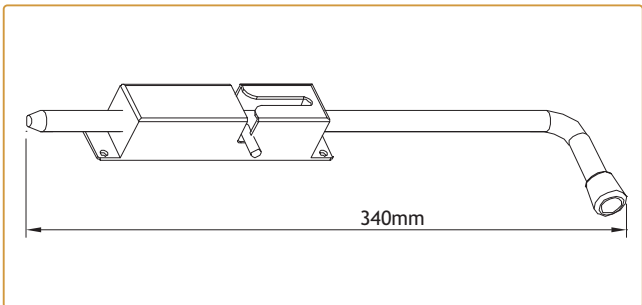

340mm

201424

FECHO CULATRA 16064 INOX



União para ligação dos montantes com inclinação variável

212915

CONJUNTO UNIÃO P/MONTANTE RA 857

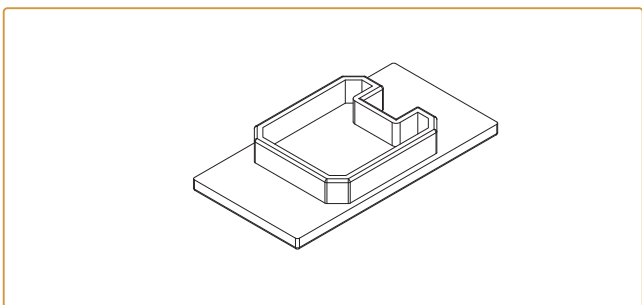

210039

TOPO SIMPLES PARA PA 31

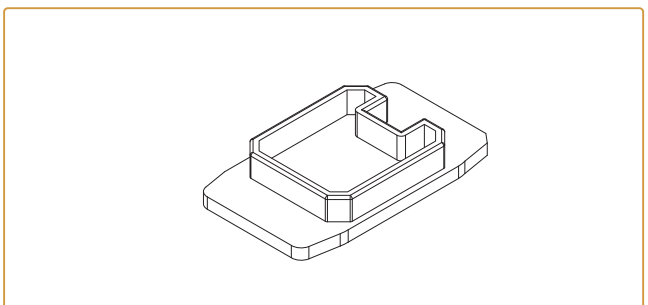

210040

TOPO SIMPLES PARA PA 41

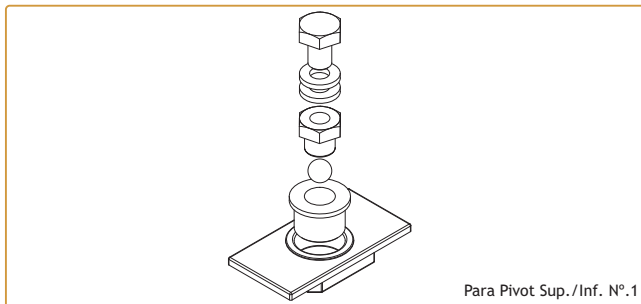

Para Pivot Sup./Inf. Nº.1

210042

TOPO PIVOT SUPERIOR Nº.2 PARA PA 31

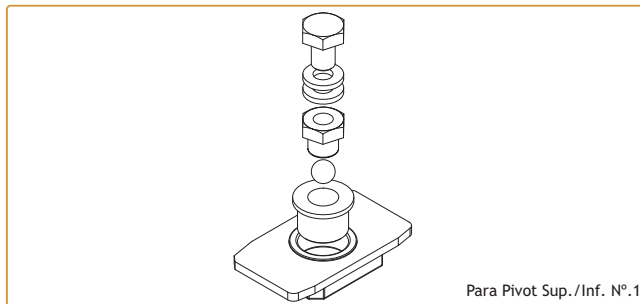

Para Pivot Sup./Inf. Nº.1

210045

TOPO PIVOT SUPERIOR Nº.5 PARA PA 41

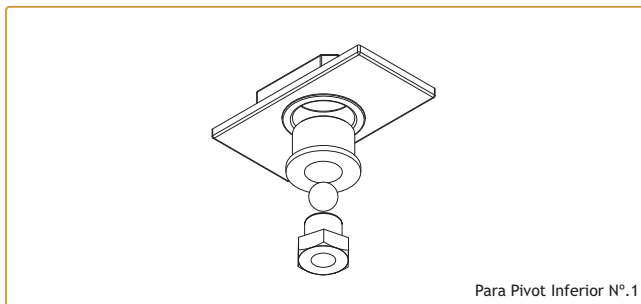

Para Pivot Inferior Nº.1

210041

TOPO PIVOT INFERIOR Nº.1 PARA PA 31

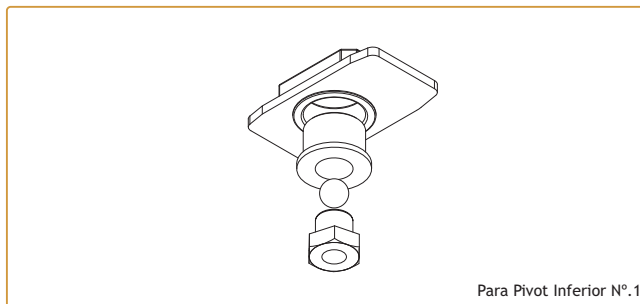

Para Pivot Inferior Nº.1

210044

TOPO PIVOT INFERIOR Nº.4 PARA PA 41

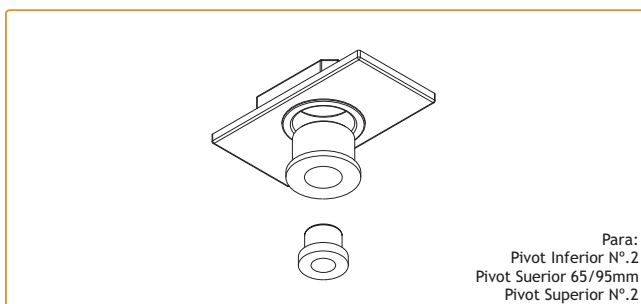

Para:
Pivot Inferior Nº.2
Pivot Superior 65/95mm
Pivot Superior Nº.2

210043

TOPO PIVOT Nº.3 PARA PA 31

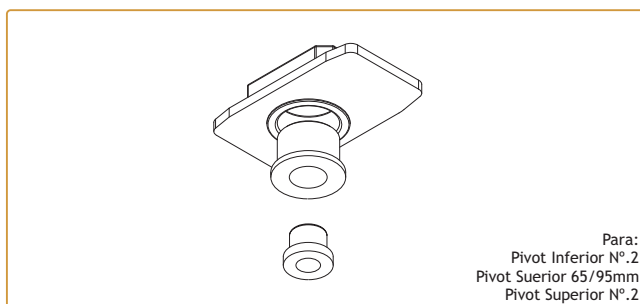

Para:
Pivot Inferior Nº.2
Pivot Superior 65/95mm
Pivot Superior Nº.2

210046

TOPO PIVOT Nº.6 PARA PA 41

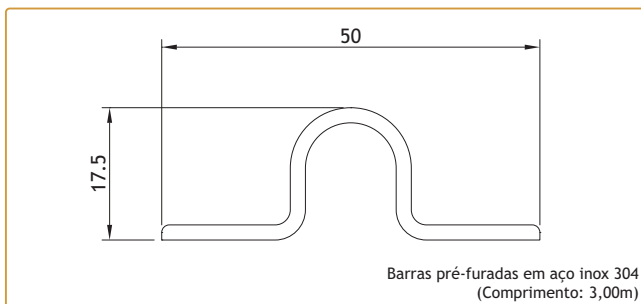

Barras pré-furadas em aço inox 304
(Comprimento: 3,00m)

207136

GUIA INOX PA 20049 (3m)

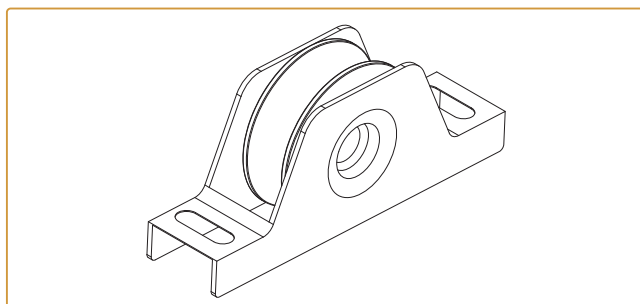

207280
207281

ROLAMENTO PA Nº. 3 INOX
ROLAMENTO PA Nº. 4 AÇO GALVANIZADO

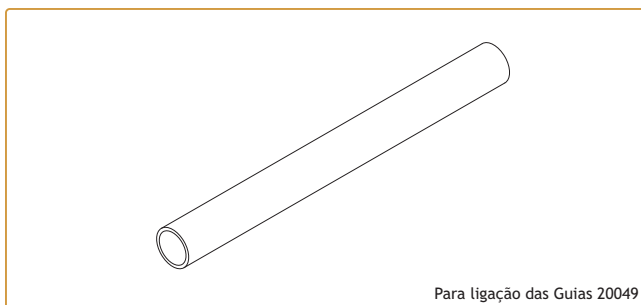

Para ligação das Guias 20049

232009

UNIÃO PARA GUIA INOX 20052

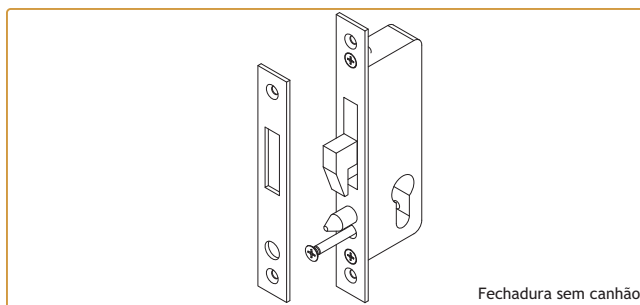

Fechadura sem canhão

201038

FECHADURA DE GANCHO SEM CILINDRO 9796

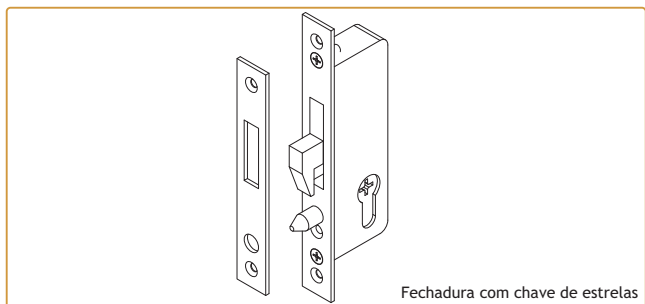

FECHADURA COM CHAVE DE ESTRELAS

201039 FECHADURA DE GANCHO 9796/S

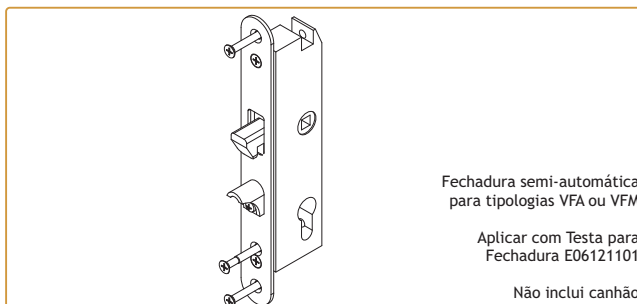

FECHADURA SEMI-AUTOMÁTICA PARA TIPOLOGIAS VFA OU VFM

Aplicar com Testa para Fechadura E06121101

Não inclui canhão

201614 FECHADURA PRUMO 11552

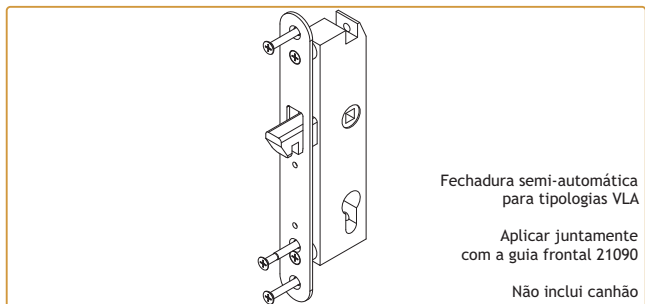

FECHADURA SEMI-AUTOMÁTICA PARA TIPOLOGIAS VLA

Aplicar juntamente com a guia frontal 21090

Não inclui canhão

201613 FECHADURA PRUMO 11553 PGR

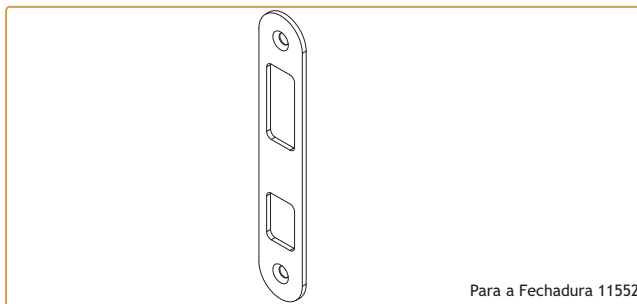

PARA A FECHADURA 11552

280243 TESTA PARA FECHADURA E06121101

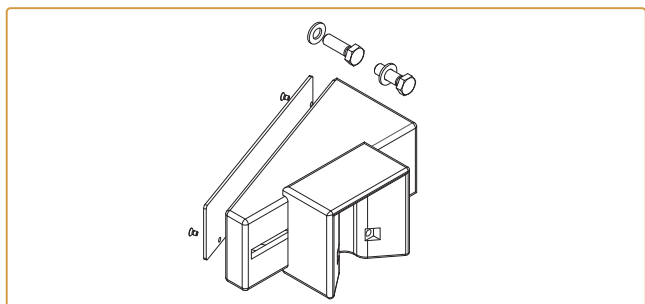

FECHO LATERAL REG. 21060

201813

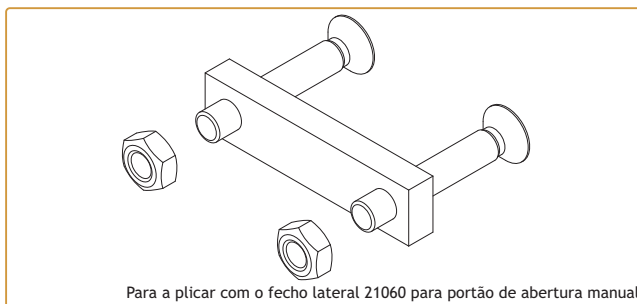

PARA APLICAR COM O FECHO LATERAL 21060 PARA PORTÃO DE ABERTURA MANUAL

202100 CONTRA-FECHO INOX 21080

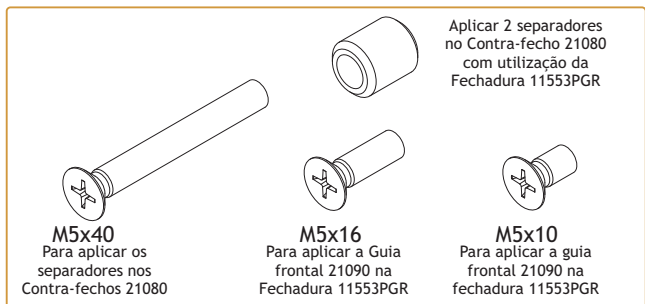

APLICAR 2 SEPARADORES NO CONTRA-FECHO 21080 COM UTILIZAÇÃO DA FECHADURA 11553PGR

M5x40
Para aplicar os separadores nos
Contra-fechos 21080

M5x16
Para aplicar a Guia
frontal 21090 na
Fechadura 11553PGR

M5x10
Para aplicar a guia
frontal 21090 na
fechadura 11553PGR

210012 SEPARADOR 714

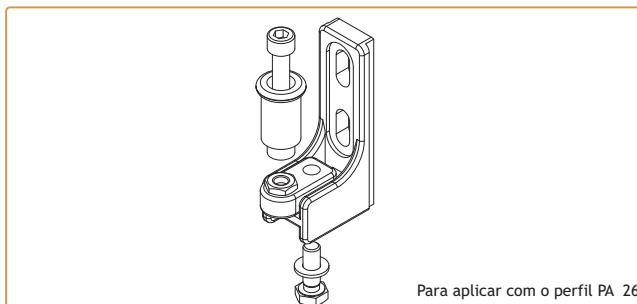

PARA APLICAR COM O PERFIL PA 26

207508 GUIA REGULÁVEL 21010

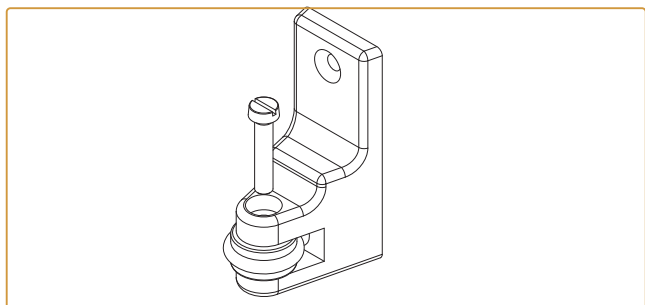

GUIA FRONTAL 21090

207138

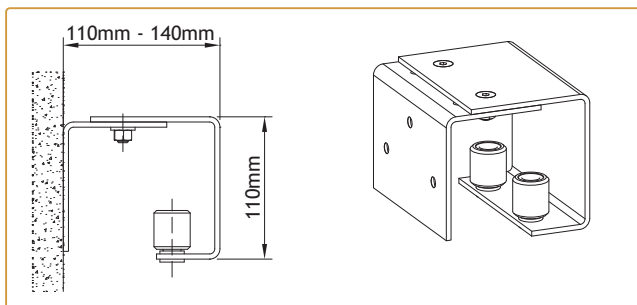

223053
223054

KIT GUIAS DE CORRER INOX
KIT GUIAS DE CORRER ALUMÍNIO

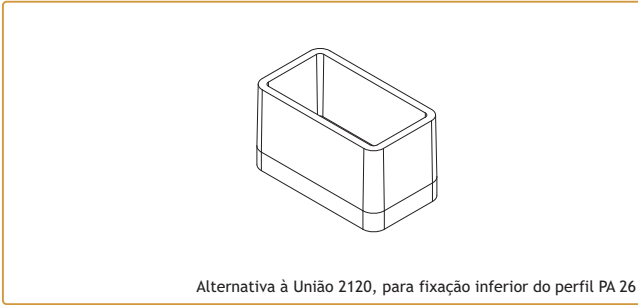

Alternativa à União 2120, para fixação inferior do perfil PA 26

232012

UNIÃO PA 18153

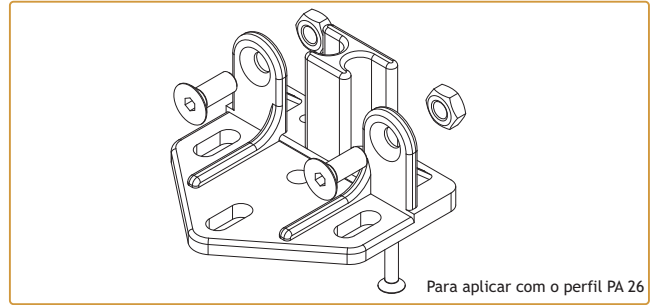

Para aplicar com o perfil PA 26

232011

UNIÃO 21020

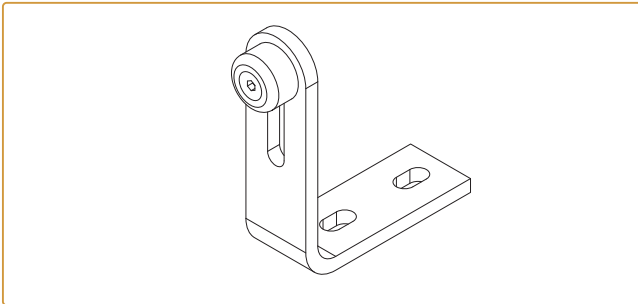

214029
214028

BATENTE PA Nº.1 INOX
BATENTE PA Nº.2 GALVANIZADO

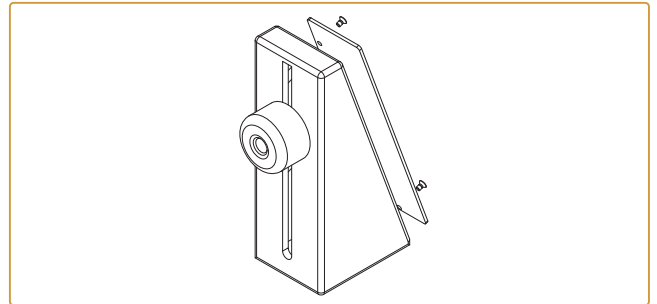

214021

BATENTE CORRER 21110

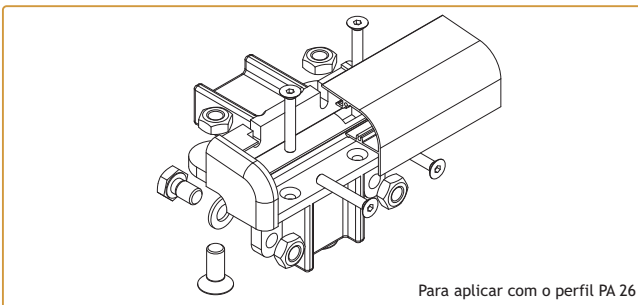

Para aplicar com o perfil PA 26

213012

CANTO 21030

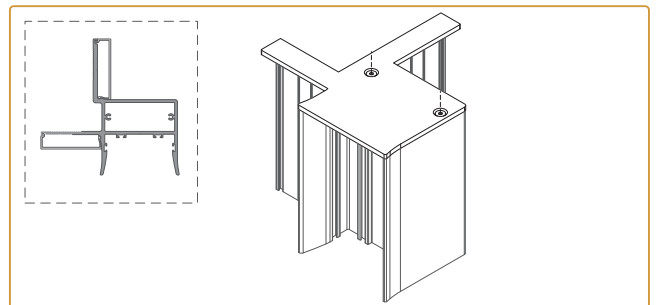

210038

TOPO PARA PA 66

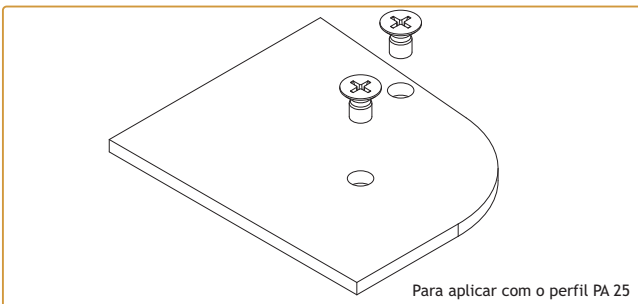

Para aplicar com o perfil PA 25

210033

TOPO GUIA 21042

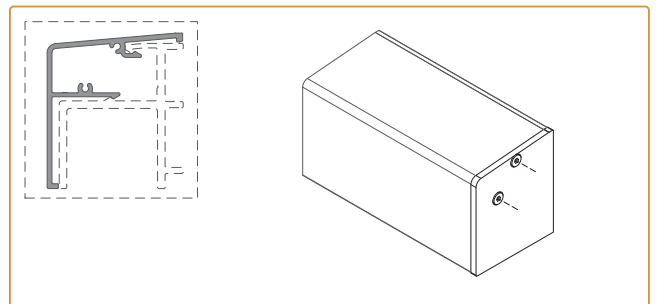

210037

TOPO PARA PA 65

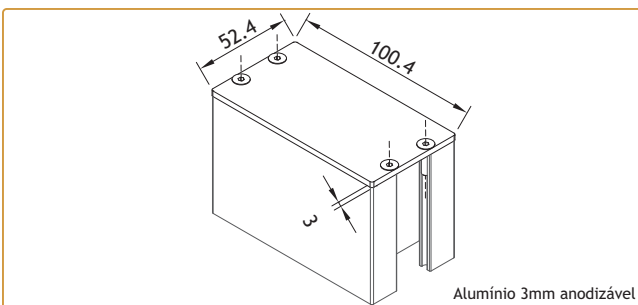

210008

TOPO PARA PA 31

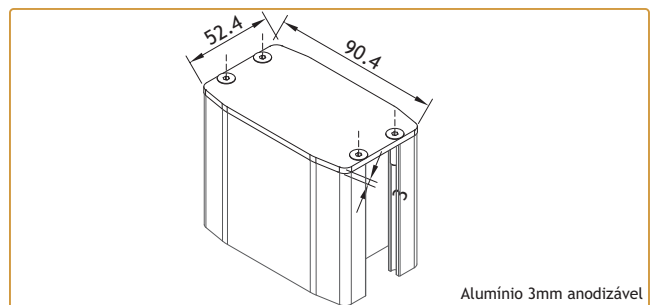

210036

TOPO PARA PA 41

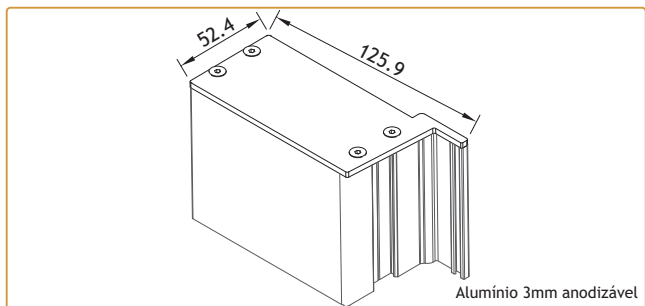

Alumínio 3mm anodizável

210034

TOPO PARA PA 37

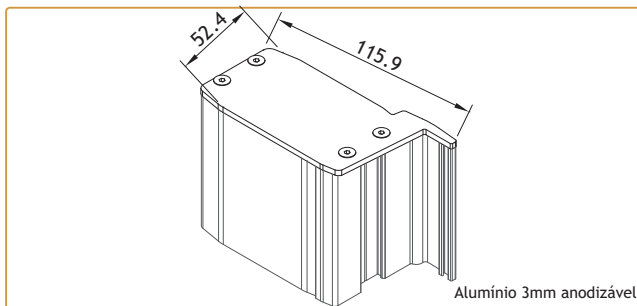

Alumínio 3mm anodizável

210007

TOPO PARA PA 30

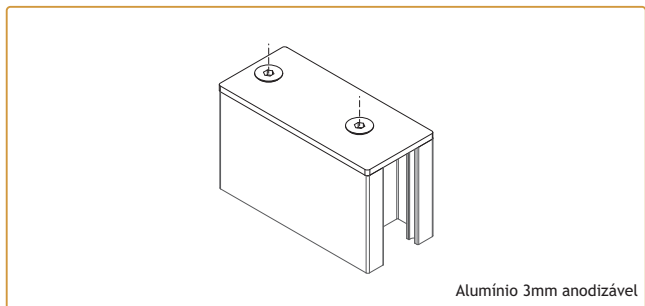

Alumínio 3mm anodizável

210009

TOPO PARA PA 34

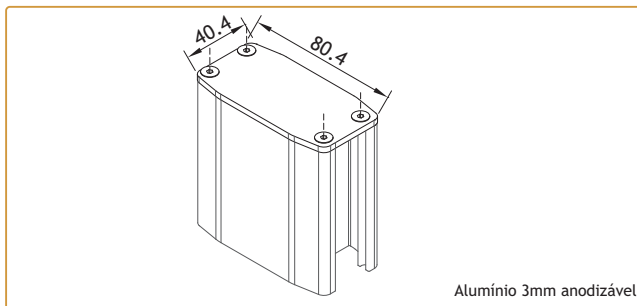

Alumínio 3mm anodizável

210052

TOPO PARA PA 42

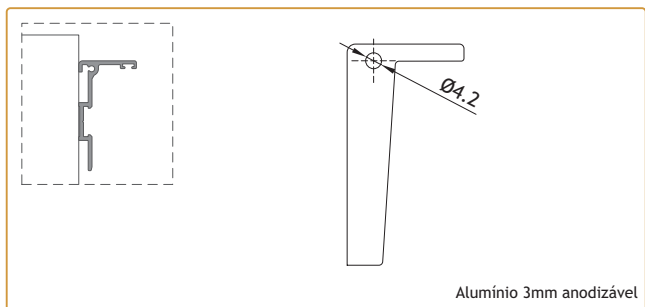

Alumínio 3mm anodizável

210049

TOPO PA 37B

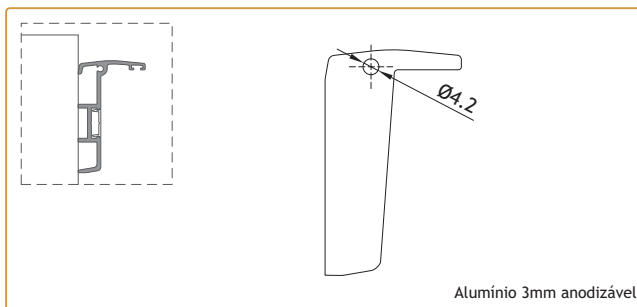

Alumínio 3mm anodizável

210048

TOPO PA 30B

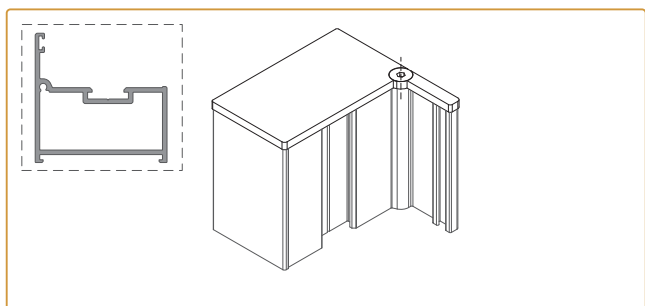

210035

TOPO PARA PA 38

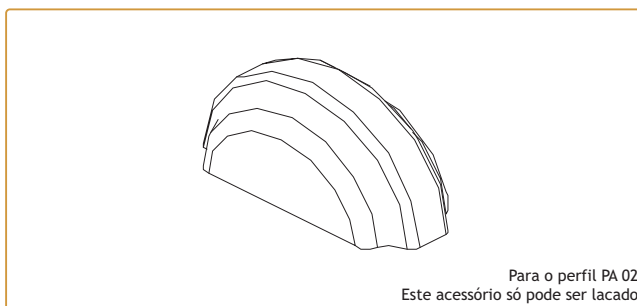

Para o perfil PA 02
Este acessório só pode ser lacado

210284

TOPO GERÇ-001

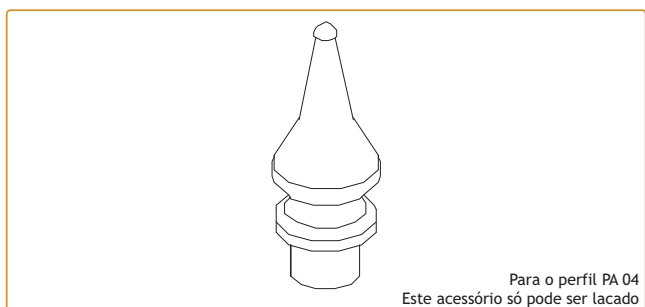

Para o perfil PA 04
Este acessório só pode ser lacado

210021

TOPO DECORATIVO GERÇ-002

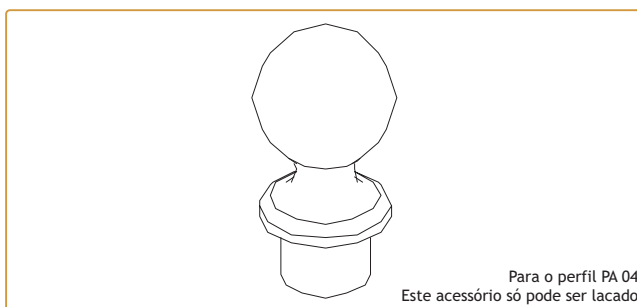

Para o perfil PA 04
Este acessório só pode ser lacado

210022

TOPO DECORATIVO GERÇ-003

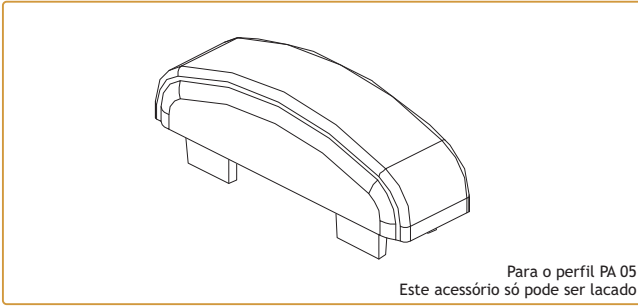

210003

TOPO PARA PA 05

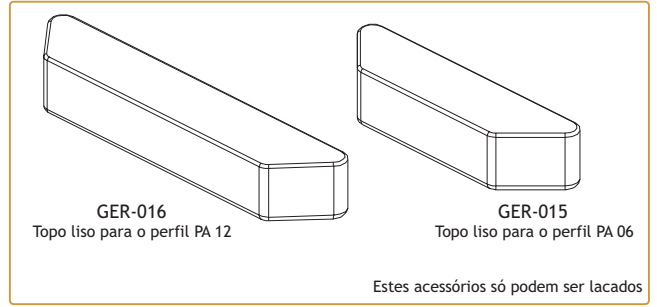

210249
210253

TOPO PA 06 GER-015
TOPO PA 12 GER-016

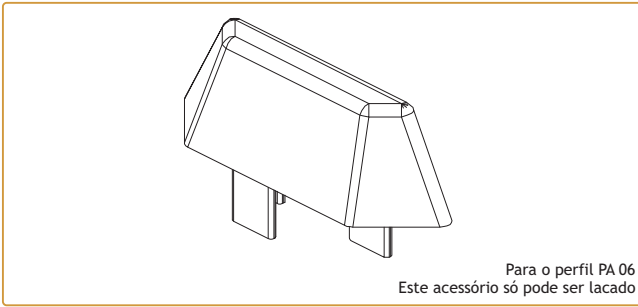

210004

TOPO PARA O PA 06

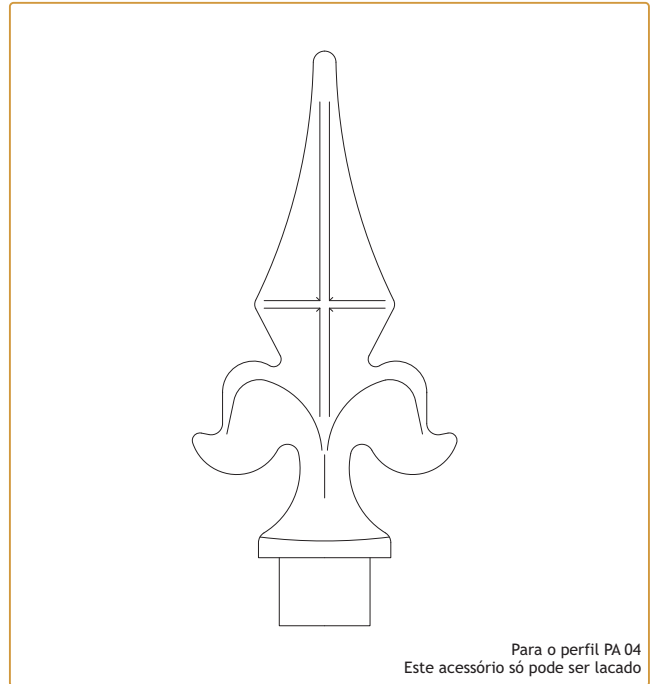

210023

TOPO DECORATIVO GER-006

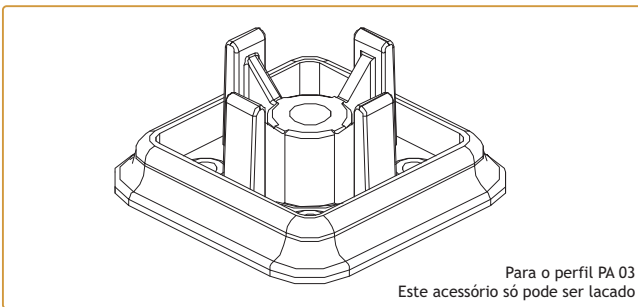

206150

PATER VERTICAL GER-004

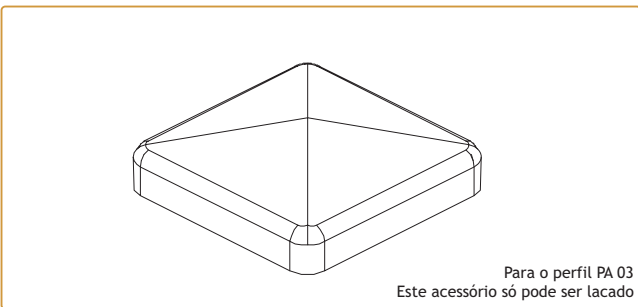

207005

TAMPA GER-005

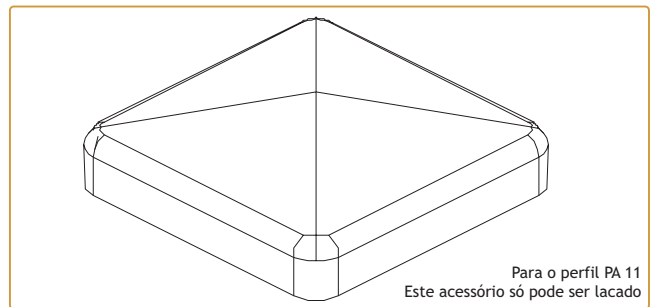

207006

TAMPA GER-008

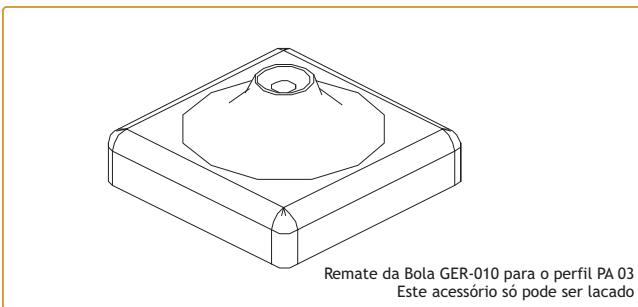

207205

REMATE PARA BOLA GER-009

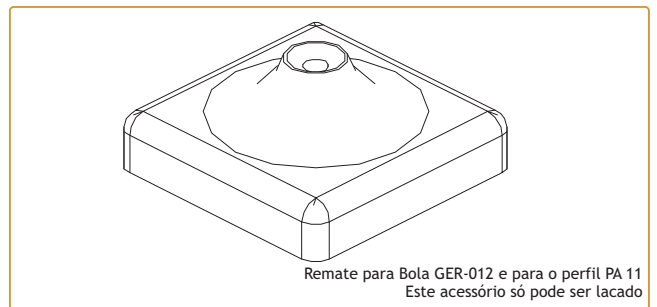

207206

REMATE PARA BOLA GER-011

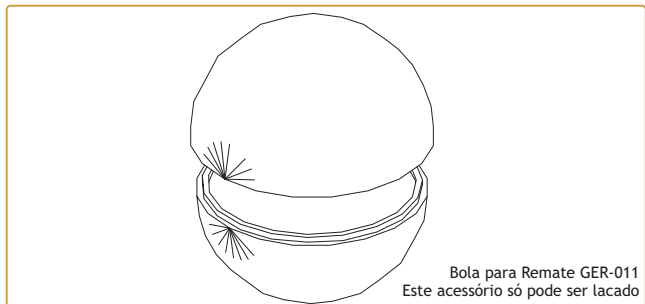

Bola para Remate GER-011
Este acessório só pode ser lacado

207082

BOLA 100 GER-012

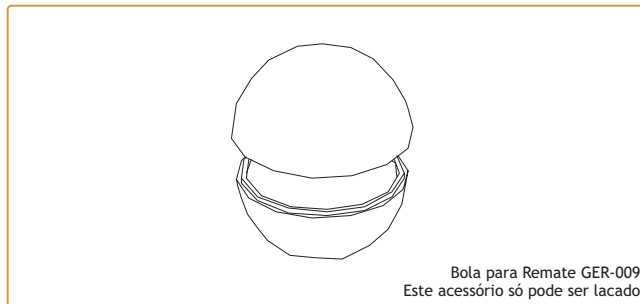

Bola para Remate GER-009
Este acessório só pode ser lacado

207080

BOLA 80 GER-010

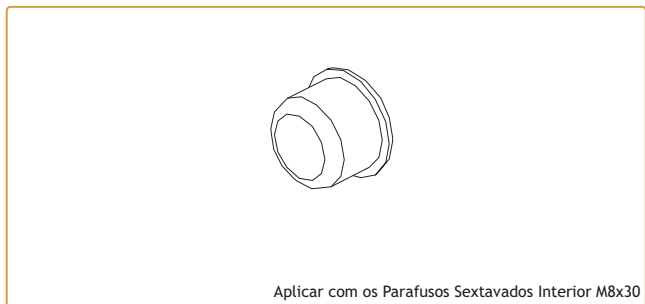

Aplicar com os Parafusos Sextavados Interior M8x30

210169
210015
210013

TAPA-FUROS 13mm (Br./Pr.)
TAPA-FUROS 10mm PRETO
TAPA-FUROS 10mm BRANCO

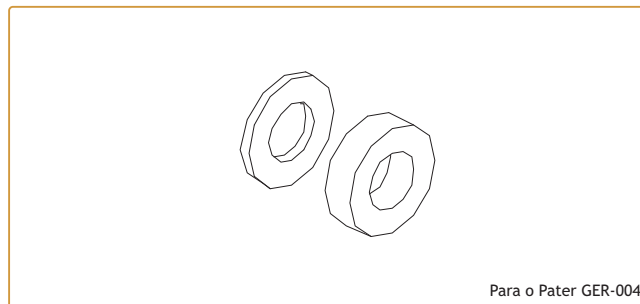

Para o Pater GER-004

217104

ANILHA COLADA AN001 INOX

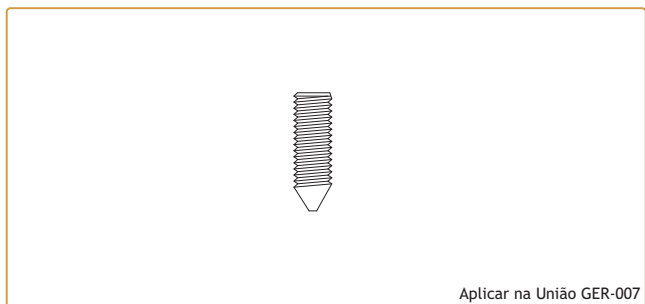

Aplicar na União GER-007

290480

PARAFUSO UMBRAKO M5x16 INOX



Aplicar com os parafusos sextavados M6x80 e M6x100

217114

ANILHA PLANA M6 INOX

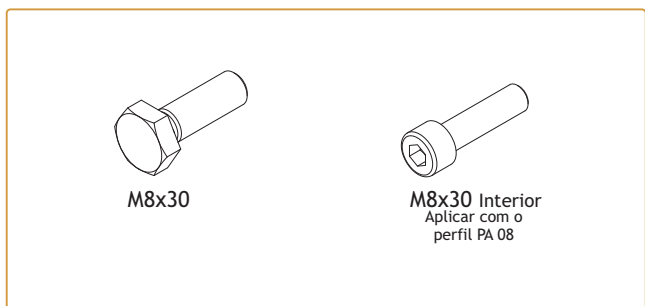

M8x30

M8x30 Interior
Aplicar com o perfil PA 08

290454
290456

PARAFUSO SEXTAVADO M8x30 INOX
PARAFUSO SEXTAVADO INTERIOR M8x30 INOX

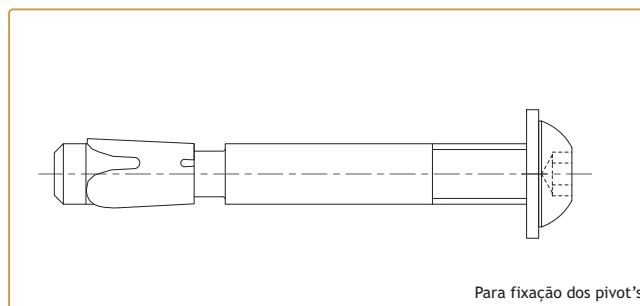

Para fixação dos pivot's

290267
290268

PARAF. M8x60 INOX A2 C/ANILHA M8 e BUCHA METÁLICA
PARAF. M10x70 INOX A2 C/ANILHA M8 e BUCHA METÁLICA

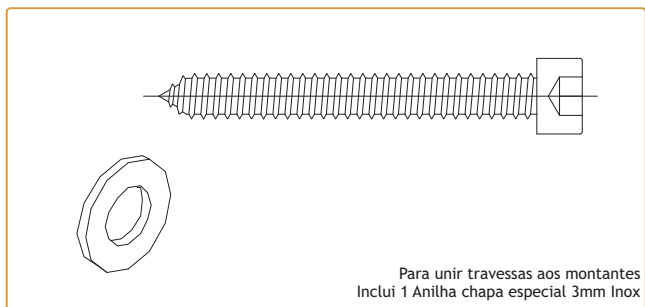

Para unir travessas aos montantes
Inclui 1 Anilha chapa especial 3mm INOX

290270

PARAFUSO 6,3x50 + ANILHA CHP ESP. 6,4x17x3 INOX A2

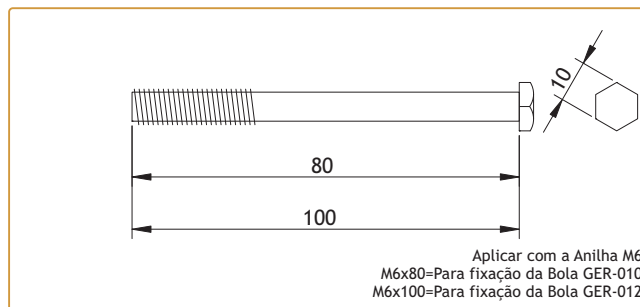

Aplicar com a Anilha M6
M6x80=Para fixação da Bola GER-010
M6x100=Para fixação da Bola GER-012

290450
290452

PARAFUSO SEXTAVADO M6x80 INOX
PARAFUSO SEXTAVADO M6x100 INOX

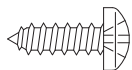

Para fixação das Lâminas PA 50

290111

PARAFUSO CQ 4,2x13 INOX A2

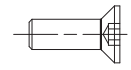

Para fixação das Tampas 3mm

210045

PARAFUSO M4x12 INOX A2

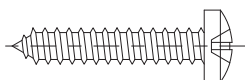

Para fixação dos Rolamentos PA

290171

PARAFUSO CQ 1x10

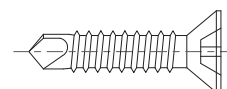

Para fixação dos Rolamentos PA

290113

PARAFUSO CX 6,3x32 INOX

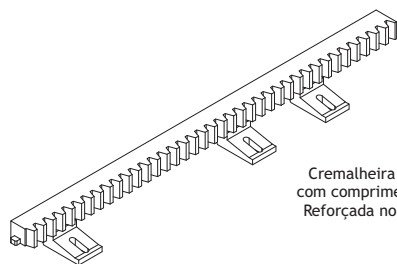

Cremalheira para automatismo, com comprimento de 1,00m cada
Reforçada no interior com perno 10x10mm, em aço

SOB ENCOMENDA

000000

CREMALHEIRA EM POLÍMERO PRETA

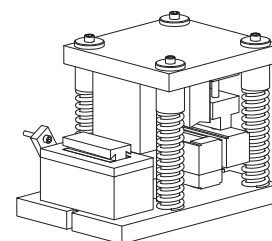

Apenas para Linha Reta

408055

CORTANTE PA+



Para aplicação nos seguintes produtos:

- Topo GER-001
- Topo GER-002
- Topo GER-003
- Topo GER-005
- Topo GER-006
- Topo GER-008
- Topo GER-009
- Topo GER-011
- Topo GER-015
- Topo GER-016
- Topo PA 05
- Topo PA 06

208001

MASTIQUE-COLA REMAFLEX 521



Junta de vedação elástica, resistente aos UV
Impede a corrosão de penetrar pelas zonas cortadas

208019

SELA JUNTAS 150gr. (Cinza)



Limpeza de alumínio lacado ou anodizado
Para preparação das zonas a serem unidas e limpeza final

208704

PRODUTO DE LIMPEZA DE ALUMÍNIO (1L) Transparente



Pormenores de montagem

Assembly details
Détails d'assemblage





EXEMPLOS DE POSSÍVEIS TIPOLOGIAS EM PORTÕES DE BATENTE

EXAMPLES OF POSSIBLE TYPOLOGIES IN SWING GATES

EXEMPLES DE POSSIBLE TYPOLOGIES EN PORTAILS DE BATTANTE

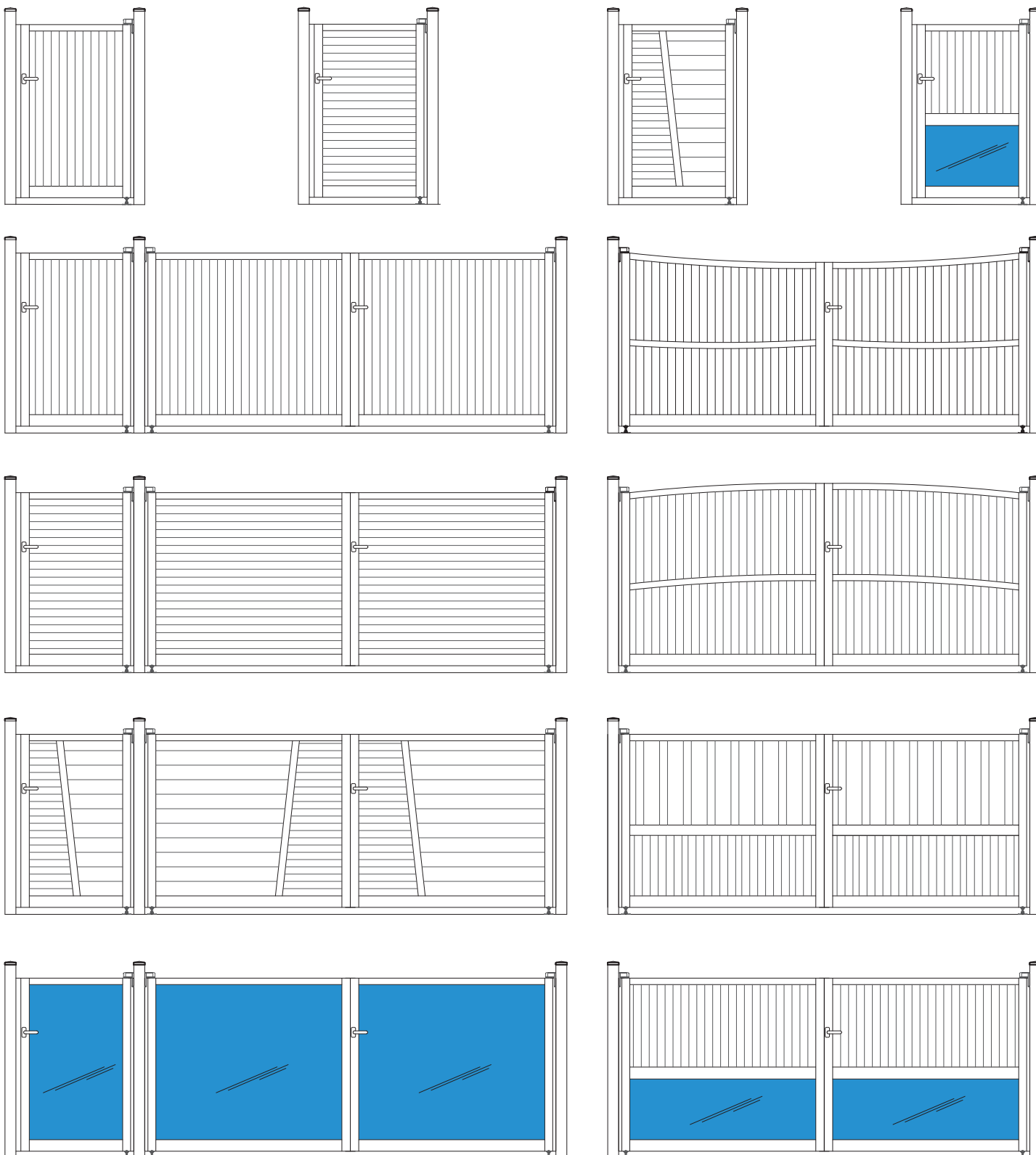

MUITO MAIS TIPOLOGIAS SÃO POSSÍVEIS...

MANY MORE TYPOLOGIES ARE POSSIBLE...
PLUSIEURS DES TYPOLOGIES SONT POSSIBLE...

S/ESC.

PORTÃO DE BATENTE 1 FOLHA COM DOBRADIÇA - LINHA RETA

1 LEAF OPENING GATE WITH HINGE - STRAIGHT LINE

PORTAIL À BATTANTE 1VANTAIL AVEC PAUMELLE - LIGNE DROIT

PERFIS PROFILES PROFILS				
REFERÊNCIA REFERENCE REFERENCIE	CORTE HORIZONTAL HORIZONTAL DETAIL DÉTAIL HORIZONTAL	CORTE VERTICAL VERTICAL DETAIL DÉTAIL VERTICALE	QUANTIDADE QUANTITY QUANTITÉ	CORTE CUT COUPÉ
PA-31	-	H	2	
PA-38	-	H+x	2	
PA-51	-	H	3	
PA-37	-	H	1	
PA-34	L-136	-	2	
PA-50	L-292	-	Variável Variable Variable	
PA-33	L-136	-	1	
KB-49*	L-136	-	1	
AT-30	-	H+x	1	
PA-03	-	Opção Option Option	2	

* Opcional | Optional | Optionnel

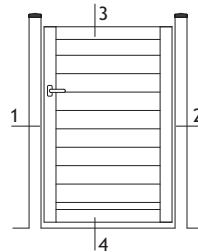

ACESSÓRIOS ACCESSORIES ACCESSOIRES		
CÓDIGO CODE	DESIGNAÇÃO DESIGNATION DÉSIGNATION	QUANTIDADE QUANTITY QUANTITÉ
200028	PUXADOR DUPLO 874.31 DOUBLE HANDLE POIGNÉE DOUBLE	1
227301	QUADRA AÇO 8mm SQUARE SPINDLE 8mm CARRÉ 8mm	1
201134	FECHADURA PRUMO PA T40 LOCKER SERRURE	1
280220	TESTA PARA FECHADURA PRUMO 2000 STRICKING PLATE GÂCHE	1
230017	SEGREDO 30/30 CYLINDER LOCK CILINDRE DE SERRURE	1
202611	DOBRADIÇA 2 ABAS 1146.1/62.5 2-WING HINGE 1146.1/62.5 PAUMELLE 2 LAMES 1146.1/62.5	2*
223100	KIT FIXAÇÃO PARA MECANICA 1145.705 FASTENING KIT FOR MECHANICA 1145.705 KIT DE FIXATION POUR MECANICA 1145.705	2*
214029	BATENTE PA N°1 INOX JAMB PA N°1 STAINLESS STEEL BATTANTE N°1 ACIER INOX	1*
210008	TOPO PARA PA 31 END CAP FOR PA31 EMBOUT POUR PA31	2
210035	TOPO PARA PA 38 END CAP FOR PA38 EMBOUT POUR PA38	4
210034	TOPO PARA PA37 END CAP FOR PA37 EMBOUT POUR PA37	2
206150	PATER VERTICAL GER-004 COLUMN SUPPORT GER-004 SABOT SUR DALE GER-004	2*
207005	TAMPA GER-005 END CAP GER-005 EMBOUT GER-005	2*
290270	PAR. 6, 3x50 Inox AZ+ANILHA SCREW 6,3x50 Stainless steel AZ-Plated washer VIS 6,3x50 Acier inox+Rondelle	12
290111	PAR. CQ 4, 2x13 Inox (Para PA 50) SCREW CQ4, 2x13 Stainless steel (for PA50) VIS CQ4, 2x13 Acier inox (pour PA50)	Diversos Diverses Divers
291112	PAR M4x12 Inox (Para Tampas PA) SCREW M4x12 Stainless steel (for end caps PA) VIS M4x12 Acier inox (pour embouts PA)	Diversos Diverses Divers

* Opcional | Optional | Optionnel

VEDANTES SEALANTS JOINTS		
CÓDIGO CODE	DESIGNAÇÃO DESIGNATION DÉSIGNATION	QUANTIDADE QUANTITY QUANTITÉ
208008	VD 2051	3H
208221	VD 1033	8H

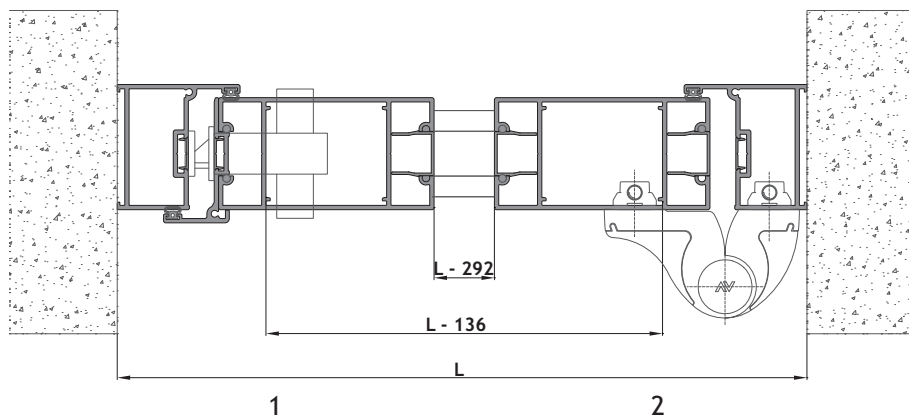
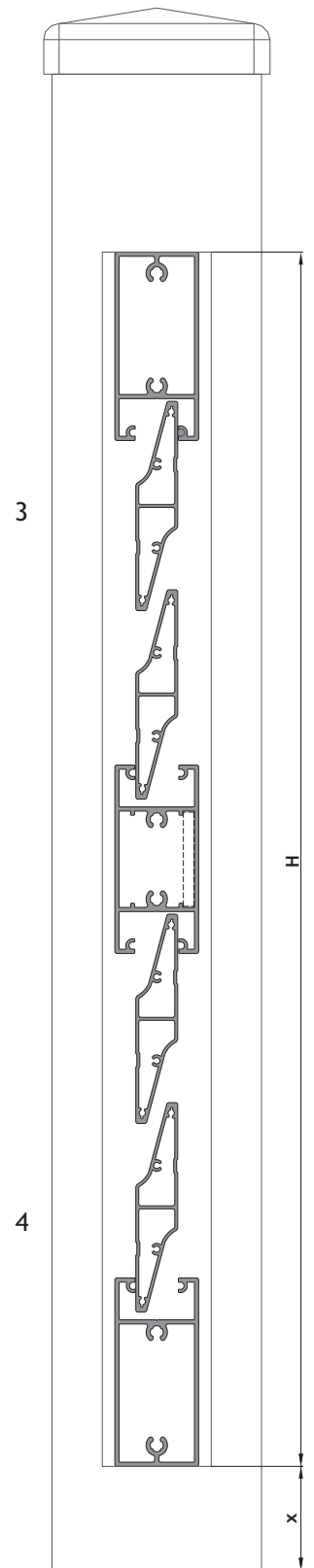

PORTÃO DE BATENTE 2 FOLHAS COM PIVOT - LINHA DECORATIVA

2 LEAVES OPENING GATE WITH PIVOT - DECORATIVE LINE

PORTAIL À BATTANTE 2 VANTAUX AVEC PIVOT - LIGNE DÉCORATIVE

PERFIS PROFILES PROFILS				
REFERÊNCIA REFERENCE REFERENCANCE	CORTE HORIZONTAL HORIZONTAL DETAIL DÉTAIL HORIZONTAL	CORTE VERTICAL VERTICAL DETAIL DÉTAIL VERTICALE	QUANTIDADE QUANTITY QUANTITÉ	CORTE CUT COUPÉ
PA-41	-	H	4	
PA-30	-	H+35	1	
PA-51	(L/2)-82	H	4+4	
PA-52	-	H	2	
PA-42	(L/2)-82	-	6	
PA-50	(L/2)-218	-	Variável Variable Variable	
KB-34*	(L/2)-82	-	2	
AT-30	-	H+35	1	
PA-03	-	Opção Option Option	2	

* Opcional | Optional | Optionnel

ACESSÓRIOS ACCESSORIES ACCESSOIRES		
CÓDIGO CODE	DESIGNAÇÃO DESIGNATION DÉSIGNATION	QUANTIDADE QUANTITY QUANTITÉ
200028	PUXADOR DUPLO 874.31 DOUBLE HANDLE POIGNÉE DOUBLE	1
227301	QUADRA AÇO 8mm SQUARE SPINDLE 8mm CARRÉ 8mm	1
201134	FECHADURA PRUMO PA T40 LOCKER SERRURE	1
280220	TESTA PARA FECHADURA PRUMO 2000 STRICKING PLATE GÂCHE	1
230017	SEGREDO 30/30 CYLINDER LOCK CILINDRE DE SERRURE	1
201025	FECHO INF. INOX P/2 FOLHAS PA16011 2 LEAVES LOWER STAINLESS STEEL LOCKER FOR 2 LEAVES PA16011 SERRURE INF. ACIER INOX POUR 2 VANTAUX PA16011	1
227119	PIVOT SUP./INF. Nº1 INOX PIVOT UPPER/LOWER Nº1 STAINLESS STEEL PIVOT SUP./INF. Nº1 ACIER INOX	2*
227121	PIVOT INFERIOR Nº1 INOX LOWER PIVOT Nº1 STAINLESS STEEL PIVOT INF. Nº1 ACIER INOX	2*
210045	TOPO PIVOT SUPERIOR Nº5 PARA PA41 UPPER PIVOT END CAP Nº5 FOR PA41 EMBOUT PIVOT SUP. Nº5 POUR PA41	2
210044	TOPO PIVOT INF Nº4 PARA PA41 LOWER PIVOT END CAP Nº4 FOR PA41 EMBOUT PIVOT INF. Nº4 POUR PA41	2*
210007	TOPO PARA PA30 END CAP FOR PA30 EMBOUT POUR PA30	4
214029	BATENTE PA Nº1 INOX STAINLESS STEEL PA JAMB Nº1 BATANTE PA Nº1 ACIER INOX	1*
206150	PATER VERTICAL GER-004 COLUMN SUPPORT GER-004 SABOT SUR DALE GER-004	2*
207005	TAMPA GER-005 END CAP GER-005 EMBOUT GER-005	2*
290270	PAR. 6, 3x50 Inox A2+ANILHA (Para travessas) SCREW 6, 3x50 Stainless steel A2+Plated washer (for transoms) VIS 6, 3x50 Acier inox+Rondelle (pour traverses)	24
290267	PAR. M8x60 Inox C/ANILHA+BUCHA (Para pivots) SCREW M8x60 Stainless steel washer/bushing (for pivots) VIS M8x60 Acier inox+Rondelle+douille (pour pivots)	8
290111	PAR. CQ 4, 2x13 Inox (Para PA 50) SCREW CQ4, 2x13 Stainless steel (for PA50) VIS CQ4, 2x13 Acier inox (pour PA50)	Diversos Diverses Divers
291112	PAR M4x12 Inox (Para Tampus PA) SCREW M4x12 Stainless steel (for end caps PA) VIS M4x12 Acier inox (pour embouts PA)	Diversos Diverses Divers

* Opcional | Optional | Optionnel

VEDANTES SEALANTS JOINTS		
CÓDIGO CODE	DESIGNAÇÃO DESIGNATION DÉSIGNATION	QUANTIDADE QUANTITY QUANTITÉ
208008	VD 2051	2H
208222	VD 2120	2H
208221	VD 1033	4L+16H

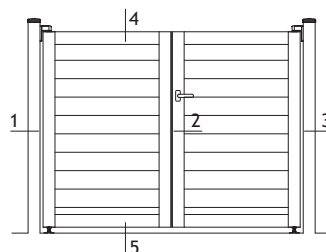

4

5

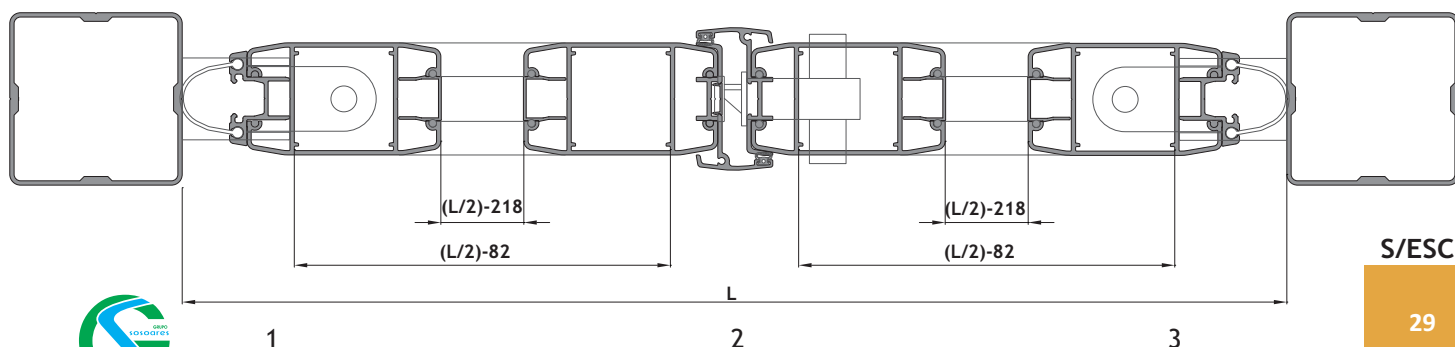
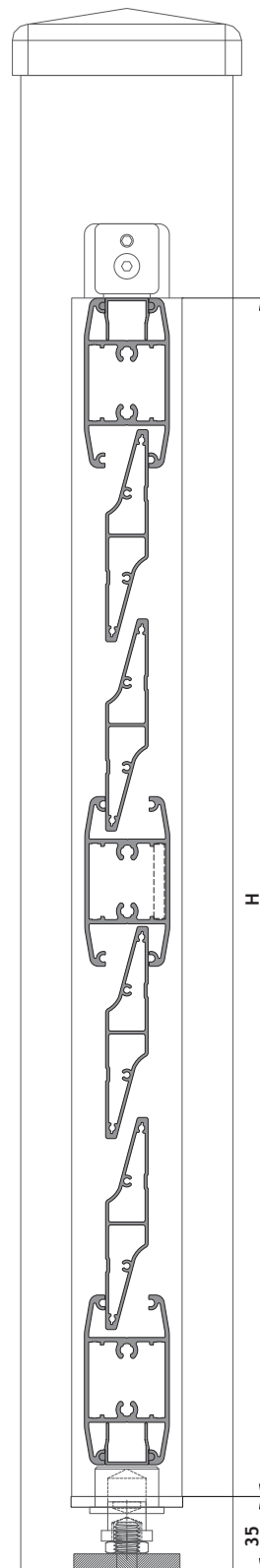

S/ESC.



**PORTÃO DE BATENTE 2 FOLHAS COM DOBRADIÇA 100Kg-180°
LINHA RETA - COM LÂMINA KW 82**

2 LEAVES OPENING GATE WITH 100Kg-180° HINGE - STRAIGHT LINE - WITH BLADE KW 82

PORTAIL À BATTANTE 2 VANTAUX AVEC PAUMELLE 100Kg-180° - LIGNE DROITE - AVEC LAME KW82

PERFIS PROFILES PROFILS				
REFERÊNCIA REFERENCE REFERANCE	CORTE HORIZONTAL HORIZONTAL DETAIL DÉTAIL HORIZONTAL	CORTE VERTICAL VERTICAL DETAIL DÉTAIL VERTICALE	QUANTIDADE QUANTITY QUANTITÉ	CORTE CUT COUPÉ
PA-31	-	H	4	■
PA-37	-	H+x	2	■
PA-37	-	H	2	■
PA-51	-	H	2	■
PA-34	(L/2)-70	-	4	■
PA-34 KW-82	(L/2)-187	-	Variável Variable Variable	■
AT-30	-	H	1	■
PA-03	-	Opcão Option Option	2	■

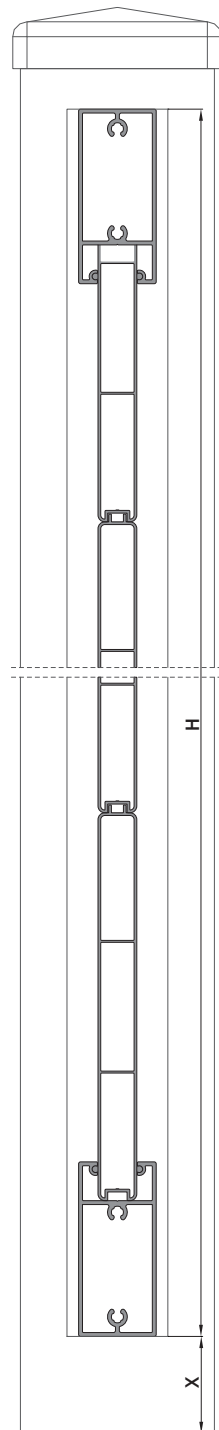
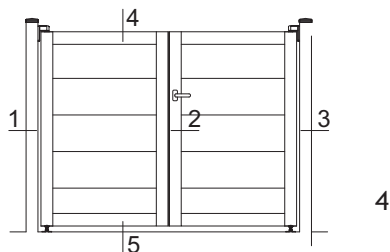

ACESSÓRIOS ACCESSORIES ACCESSOIRES		
CÓDIGO CODE	DESIGNAÇÃO DESIGNATION DÉSIGNATION	QUANTIDADE QUANTITY QUANTITÉ
200028	PUXADOR DUPLO 874.31 DOUBLE HANDLE POIGNÉE DOUBLE	1
227301	QUADRA AÇO 8mm SQUARE SPINDLE 8mm CARRÉ 8mm	1
201134	FECHADURA PRUMO PA T40 LOCKER SERRURE	1
280220	TESTA PARA FECHADURA PRUMO 2000 STRICKING PLATE GÂCHE	1
230017	SEGREDO 30/30 CYLINDER LOCK CILINDRE DE SERRURE	1
202352	DOBRADIÇA PA NOX 100Kg 100kg STAINLESS STEEL HINGE PAUMELLE ACIER INOX 100kg	4*
201025	FECHO INF. INOX P/2 FOLHAS PA16011 2 LEAVES LOWER STAINLESS STEEL LOCKER FOR 2 LEAVES PA16011 SERRURE INF. ACIER INOX POUR 2 VANTAUX PA16011	1
214029	BATENTE PA Nº. 1 INOX JAMB PA Nº. 1 STAINLESS STEEL BATTANTE Nº. 1 ACIER INOX	1*
210008	TOPO PARA PA31 END CAP FOR PA31 EMBOUT POUR PA3	4
210034	TOPO PARA PA37 END CAP FOR PA37 EMBOUT POUR PA37	4
210049	TOPO PARA PA37B END CAP FOR PA37B EMBOUT POUR PA37B	2
206150	PATER VERTICAL GER-004 COLUMN SUPPORT GER-004 SABOT SUR DALE GER-004	2*
207005	TAMPA GER-005 END CAP GER-005 EMBOUT GER-005	2*
290270	PAR. 6, 3x50 Inox A2+ANILHA (Para travessas) SCREW 6, 3x50 Stainless steel A2+Plated washer (for transoms) VIS 6, 3x50 Acier inox+Rondelle (pour traverses)	24
291112	PAR M4x12 Inox (Para Tampas PA) SCREW M4x12 Stainless steel (for end caps PA) VIS M4x12 Acier inox (pour embouts PA)	Diversos Diverses Divers

* Opcional | Option | Option

VEDANTES SEALANTS JOINTS		
CÓDIGO CODE	DESIGNAÇÃO DESIGNATION DÉSIGNATION	QUANTIDADE QUANTITY QUANTITÉ
208008	VD 2051	4H
208221	VD 1033	4L+16H

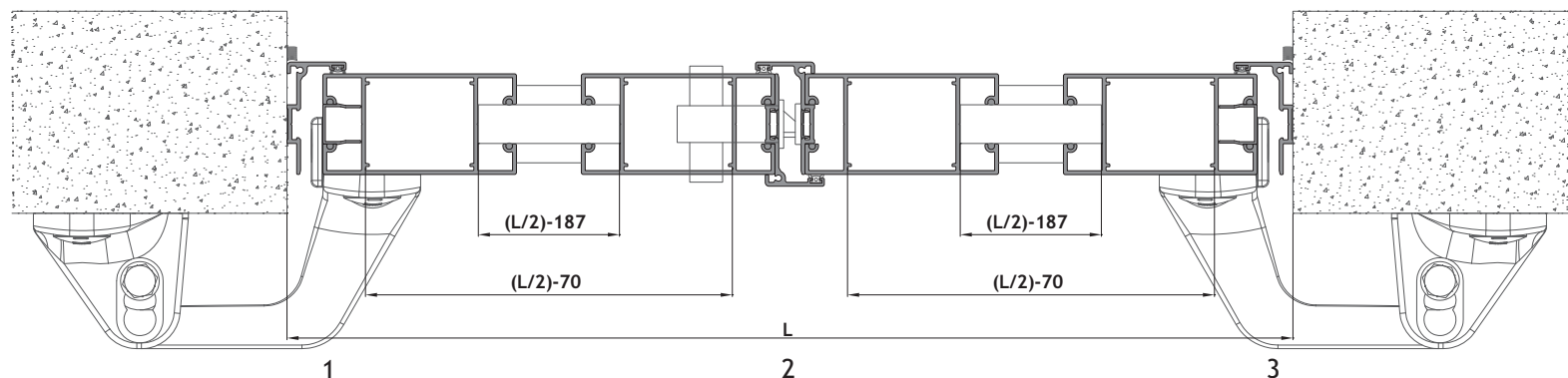

S/ESC.

EXEMPLOS DE POSSÍVEIS TIPOLOGIAS EM PORTÕES DE CORRER

EXAMPLES OF POSSIBLE TYPOLOGIES IN SLIDING GATES

EXEMPLES DE POSSIBLE TYPOLOGIES EN PORTAILS COULISSANTS

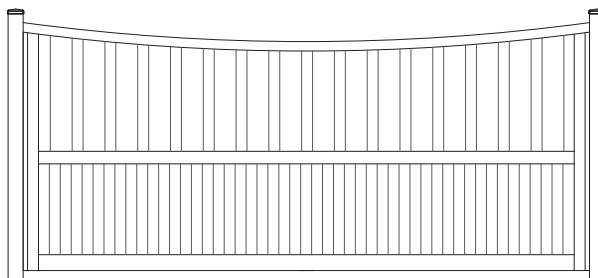
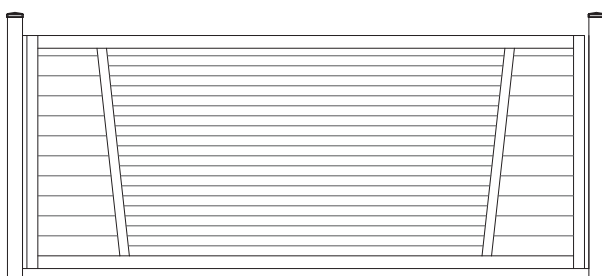
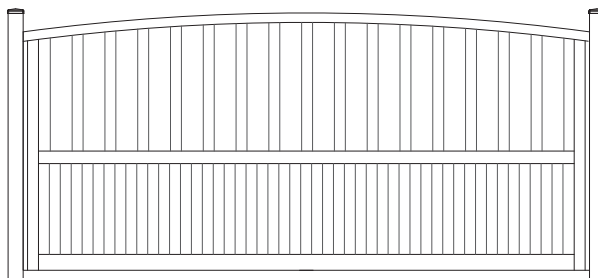
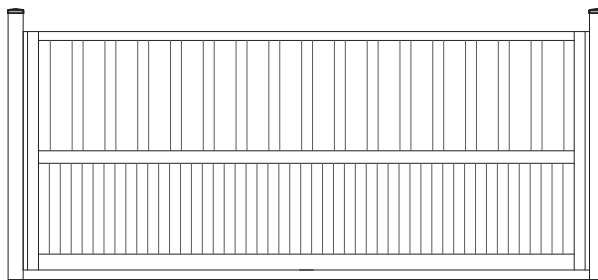
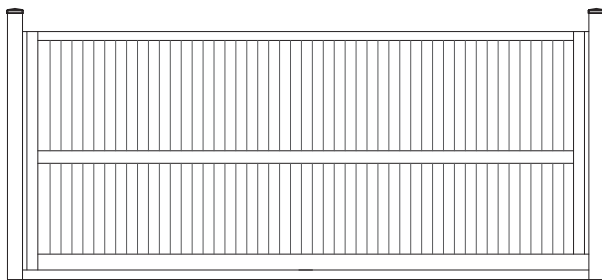

MUITO MAIS TIPOLOGIAS SÃO POSSÍVEIS...

MANY MORE TYPOLOGIES ARE POSSIBLE...

PLUSIEURS DES TYPOLOGIES SONT POSSIBLE...

ABERTURAS | OPENINGS | OUVERTURES

VLM VARIANTE LATERAL COM FECHO MANUAL
LATERAL SOLUTION WITH MANUAL LOCKING
SOLUTION LATÉRAL AVEC FERMETURE MANUEL

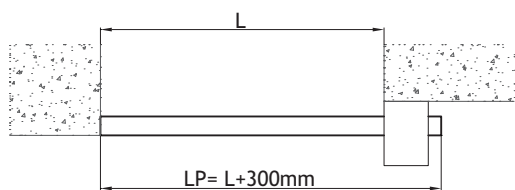

VFA VARIANTE FRONTAL COM AUTOMATISMO
FRONTAL SOLUTION WITH AUTOMATISM
SOLUTION FRONTAIL AVEC AUTOMATISME

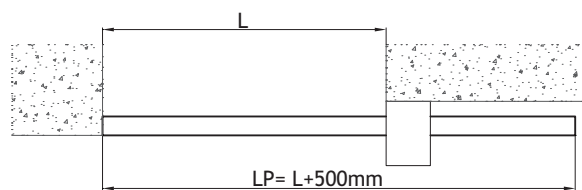

PORTÃO DE CORRER COM GUIA PA 65 - LINHA RETA

SLIDING GATE WITH GUIDE PA 65 - STRAIGHT LINE

PORTAIL À BATTANTE AVEC GUIDE PA 65 - LIGNE DROIT

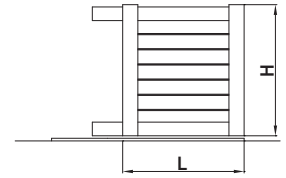

PERFIS PROFILES PROFILS				
REFERÊNCIA REFERENCE RÉFÉRENCE	CORTE HORIZONTAL HORIZONTAL DETAIL DÉTAIL HORIZONTAL	CORTE VERTICAL VERTICAL DETAIL DÉTAIL VERTICALE	QUANTIDADE QUANTITY QUANTITÉ	CORTE CUT COUPE
PA-31	-	H	2	■
PA-66	-	H+28	1	■
PA-67	-	H+28	2	■
PA-51	-	H	Com with avec PA 50 - 4 Com with avec KW 82/92 - 2	■
PA-34	LP+178	-	2	■
PA-50 Ou Or Oü	LP-200	-	Variável Variable Variable	■
KW-82 Ou Or Oü	LP-160	-	Variável Variable Variable	■
KW-92	LP-160	-	Variável Variable Variable	■
PA-33*	LP-44	-	Com with avec PA 50 - 1 Com with avec KW 82/92 - 0	■
PA-65	LP+97	-	1	■
PA-64	LP+97	-	1	■

* Opcional | Optional | Optionnel

ACESSÓRIOS ACCESSORIES ACCESSOIRES		
CÓDIGO CODE	DESIGNAÇÃO DESIGNATION DÉSIGNATION	QUANTIDADE QUANTITY QUANTITÉ
200028	PUXADOR DUPLO 874.31 DOUBLE HANDLE POIGNÉE DOUBLE	1
227301	QUADRA AÇO 8mm SQUARE SPINDLE 8mm CARRÉ 8mm	1
201614	FECHADURA PRUMO 11552 LOCKER SERRURE	1*
280243	TESTA PARA FECHADURA E06121101 STRICKING PLATE GÂCHE	1
230017	SEGREDO 30/30 CHAV NIQUELADO CYLINDER LOCK CILINDRE DE SERRURE	1
207136	GUIA INOX PA 20049 (3m) STAINLESS STEEL GUIDE (3m) GUIDE ACIER INOX(3m)	Lx2
232009	UNIÃO PARA GUIA INOX 20052 STAINLESS STEEL UNION GUIDE 20052	1**
207280	ROLAMENTO PA Nº 3 INOX ROLLING BEARING PA Nº3 STAINLESS STEEL ROULEMENT Nº3 ACIER INOX	2*
223053	KIT GUIAS CORRER INOX STAINLESS STEEL SLIDING GUIDES KIT KIT GUIDES COULISSANTES ACIER INOX	1*
214029	BATENTE PA Nº 1 INOX JAMB PA Nº1 STAINLESS STEEL BATTANTE Nº1 ACIER INOX	1*
210008	TOPO PARA PA31 END CAP FOR PA41 EMBOUT POUR PA41	4
210009	TOPO PARA PA34 END CAP FOR PA34 EMBOUT POUR PA34	2
210038	TOPO PARA PA66 END CAP FOR PA66 EMBOUT POUR PA66	1
210037	TOPO PARA PA65 END CAP FOR PA65 EMBOUT POUR PA65	2
290270	PAR. 6, 3x50 Inox A2+ANILHA (Para travessas) SCREW 6, 3x50 Stainless steel A2+Plated washer (for transoms) VIS 6, 3x50 Acier inox+Rondelle (pour traverses)	Diversos Diverses Divers
290267	PAR. M8x60 Inox C/ANILHA+BUCHA (Para guias) SCREW M8x60 Stainless steel +washer+bushing (for guides) VIS M8x60 Acier inox+Rondelle+douille (pour guides)	3
290111	PAR. CQ 4, 2x13 Inox (Para PA 50) SCREW CQ4, 2x13 Stainless steel (for PA50) VIS CQ4, 2x13 Acier inox (pour PA50)	Diversos Diverses Divers
291112	PAR. M4x12 Inox (Para Tampas PA) SCREW M4x12 Stainless steel (for end caps PA) VIS M4x12 Acier inox (pour embouts PA)	Diversos Diverses Divers
290113	PAR. CX 6, 3x32 Inox SCREW CX 6, 3x32 Stainless steel VIS CX 6, 3x32 Acier inox	4

* Opcional | Optional | Optionnel

** Para Guias > 3,00m | For Guides > 3,00m | Pour Guides > 3,00m

VEDANTES SEALANTS JOINTS		
CÓDIGO CODE	DESIGNAÇÃO DESIGNATION DÉSIGNATION	QUANTIDADE QUANTITY QUANTITÉ
208008	VD 2051	2H
208564	PELÚCIA 4,8x7 PLUSH JOINT BRASSE	2H
208221	VD 1033 PA 50	8H
	KW 82 KW 92	4L+4H

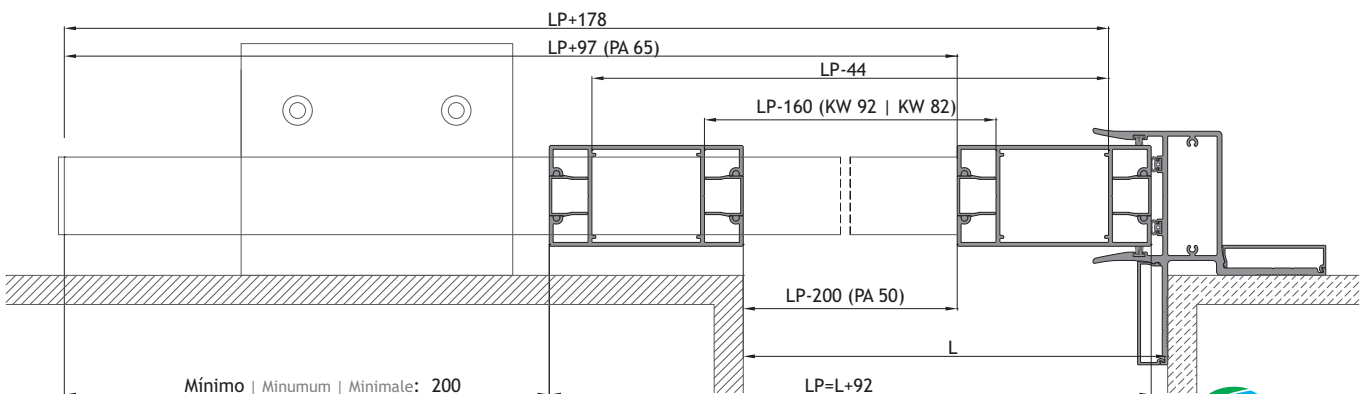
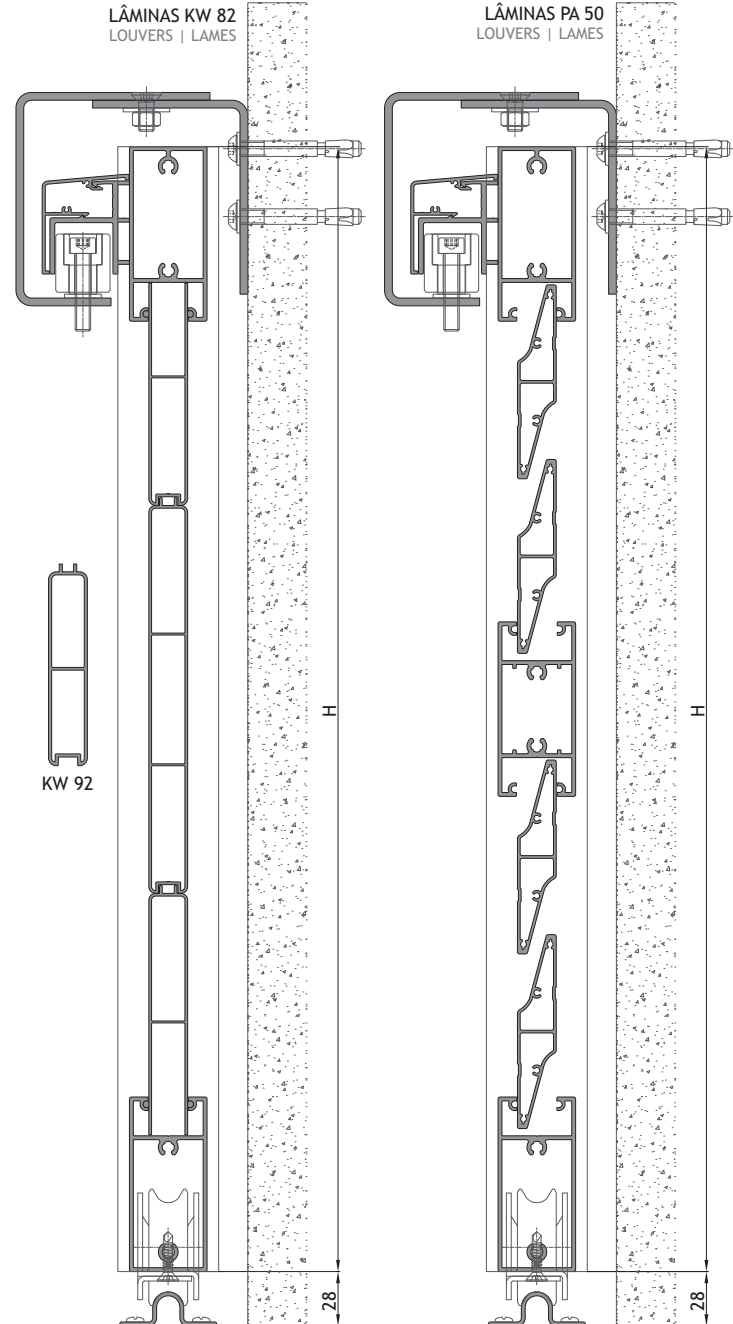

PORTÃO DE CORRER COM GUIA PA 65 - LINHA DECORATIVA

SLIDING GATE WITH GUIDE PA 65 - DECORATIVE LINE

PORTAIL À BATTANTE AVEC GUIDE PA 65 - LIGNE DÉCORATIVE

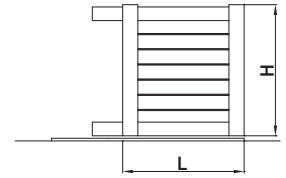

PERFIS PROFILES PROFILS				
REFERÊNCIA REFERENCE RÉFÉRENCE	CORTE HORIZONTAL HORIZONTAL DETAIL DÉTAIL HORIZONTAL	CORTE VERTICAL VERTICAL DETAIL DÉTAIL VERTICALE	QUANTIDADE QUANTITY QUANTITÉ	CORTE CUT COUPÉ
PA-41	-	H	2	■
PA-66	-	H+28	1	■
PA-67	-	H+28	2	■
PA-51	LP+178	H	Com with avec PA 50 - 1+4	■
PA-42	LP+178	-	Com with avec KW 82/92 - 1+2	■
PA-50 Ou Or Ou	LP-180	-	Variável Variable Variable	■
KW-82 Ou Or Ou	LP-140	-	Variável Variable Variable	■
KW-92	LP-140	-	Variável Variable Variable	■
PA-42*	LP-44	-	Com with avec PA 50 - 1 Com with avec KW 82/92 - 0	■
PA-65	LP+107	-	1	■
PA-64	LP+107	-	1	■

* Opcional | Option | Option

ACESSÓRIOS ACCESSORIES ACCESSOIRES		
CÓDIGO CODE	DESIGNAÇÃO DESIGNATION DÉSIGNATION	QUANTIDADE QUANTITY QUANTITÉ
200028	PUXADOR DUPLO 874.31 DOUBLE HANDLE POIGNÉE DOUBLE	1
227301	QUADRA AÇO 8mm SQUARE SPINDLE 8mm CARRÉ 8mm	1
201614	FECHADURA PRUMO 11552 LOCKER SERRURE	1*
280243	TESTA PARA FECHADURA E06121101 STRICKING PLATE GÂCHE	1
230017	SEGREDO 30/30 CHAV NIQUELADO CYLINDER LOCK CILINDRE DE SERRURE	1
207136	GUIA INOX PA 20049 (3m) STAINLESS STEEL GUIDE (3m) GUIDE ACIER INOX(3m)	Lx2
232009	UNIÃO PARA GUIA INOX 20052 STAINLESS STEEL UNION GUIDE 20052	1**
207280	ROLAMENTO PA Nº. 3 INOX ROLLING BEARING PA Nº.3 STAINLESS STEEL ROULEMENT Nº.3 ACIER INOX	2*
223053	KIT GUIAS CORRER INOX STAINLESS STEEL SLIDING GUIDES KIT KIT GUIDES COULISSANTES ACIER INOX	1*
214029	BATENTE PA Nº. 1 INOX JAMB PA Nº.1 STAINLESS STEEL BATTANTE Nº.1 ACIER INOX	1*
210036	TOPO PARA PA41 END CAP FOR PA41 EMBOUT POUR PA41	4
210052	TOPO PARA PA42 END CAP FOR PA34 EMBOUT POUR PA34	2
210038	TOPO PARA PA66 END CAP FOR PA66 EMBOUT POUR PA66	1
210037	TOPO PARA PA65 END CAP FOR PA65 EMBOUT POUR PA65	2
290270	PAR. 6, 3x50 Inox A2+ANILHA (Para travessas) SCREW 6, 3x50 Stainless steel A2+Plated washer (for transoms) VIS 6, 3x50 Acier inox+Rondelle (pour traverses)	Diversos Diverses Divers
290267	PAR. M8x60 Inox C/ANILHA+BUCHA (Para guias) SCREW M8x60 Stainless steel +washer-bushing (for guides) VIS M8x60 Acier inox+Rondelle+douille (pour guides)	3
290111	PAR. CQ 4, 2x13 Inox (Para PA 50) SCREW CQ4, 2x13 Stainless steel (for PA50) VIS CQ4, 2x13 Acier inox (pour PA50)	Diversos Diverses Divers
291112	PAR. M4x12 inox (Para Tampas PA) SCREW M4x12 Stainless steel (for end caps PA) VIS M4x12 Acier inox (pour embouts PA)	Diversos Diverses Divers
290113	PAR. CX 6, 3x32 Inox SCREW CX 6, 3x32 Stainless steel VIS CX 6, 3x32 Acier inox	4

* Opcional | Optional | Optionnel

** Para Guias > 3,00m | For Guides > 3,00m | Pour Guides > 3,00m

VEDANTES SEALANTS JOINTS		
CÓDIGO CODE	DESIGNAÇÃO DESIGNATION DÉSIGNATION	QUANTIDADE QUANTITY QUANTITÉ
208008	VD 2051	2H
208564	PELÚCIA 4,8x7 PLUSH JOINT BROSSE	2H
208221	VD 1033 PA 50	8H
	KW 82 KW 92	4L+4H

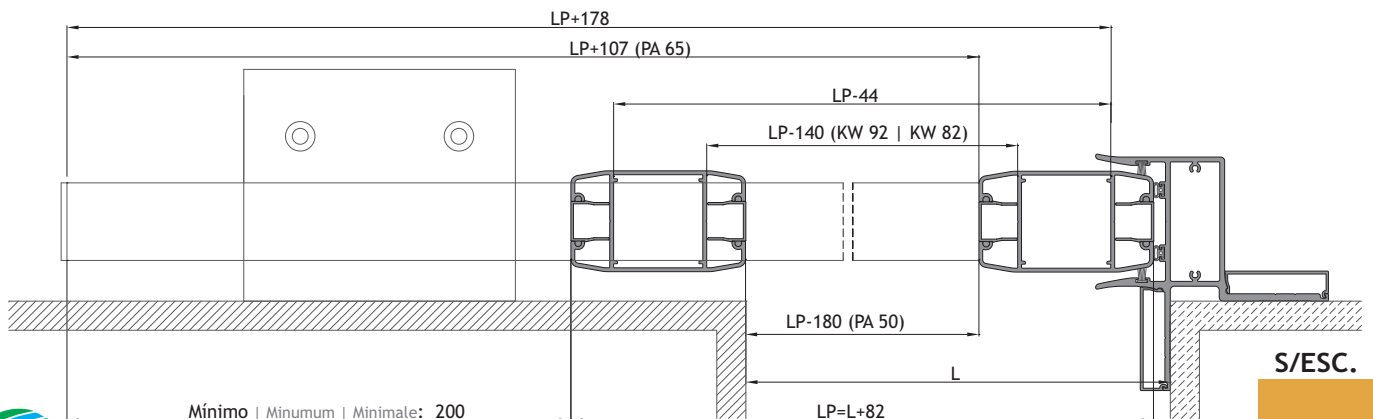
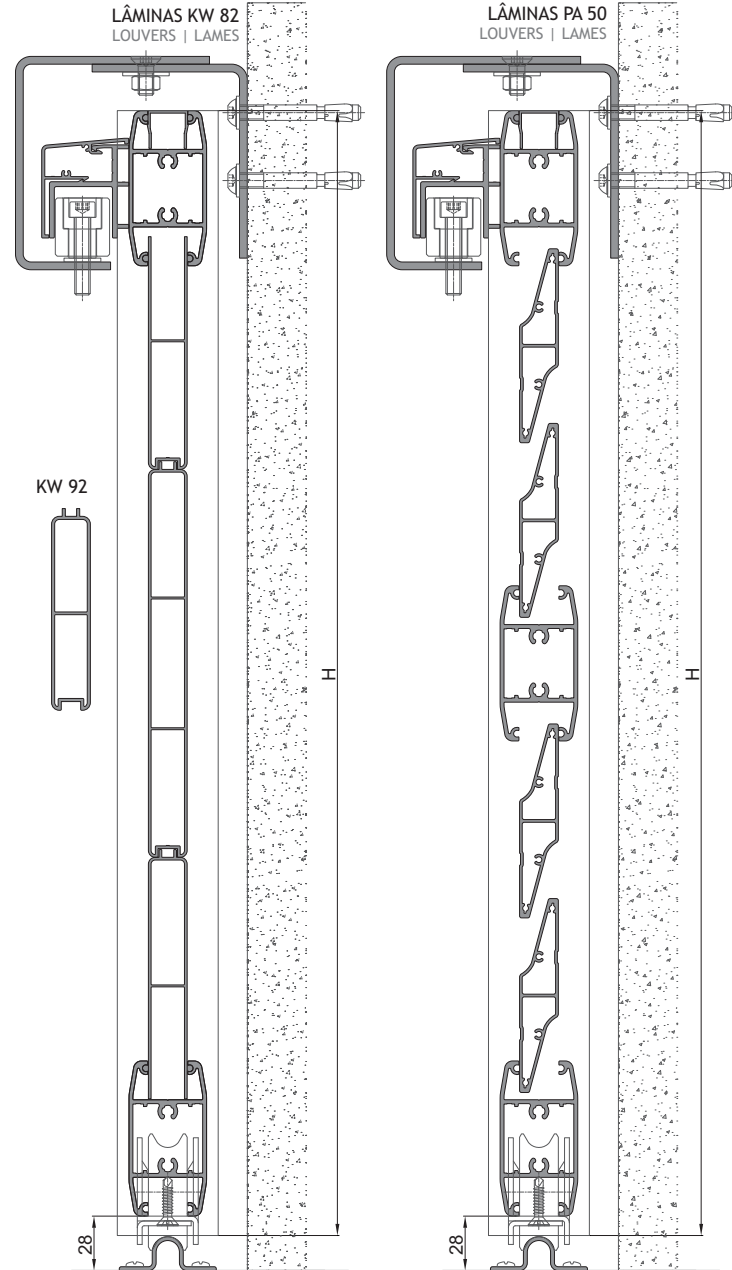

S/ESC.

MECANIZAÇÃO DOS PERFIS - PORTÕES DE BATENTE

PROFILES MECHANIZATION - JAMB GATES

MÉCANISATION DES PROFILS - PORTAILS À BATTANTE

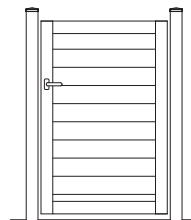

LIGAÇÃO MONTANTE - TRAVESSA
CONNECTION COLUMN-TRANSOM
CONNEXION PILIER - TRAVERSE

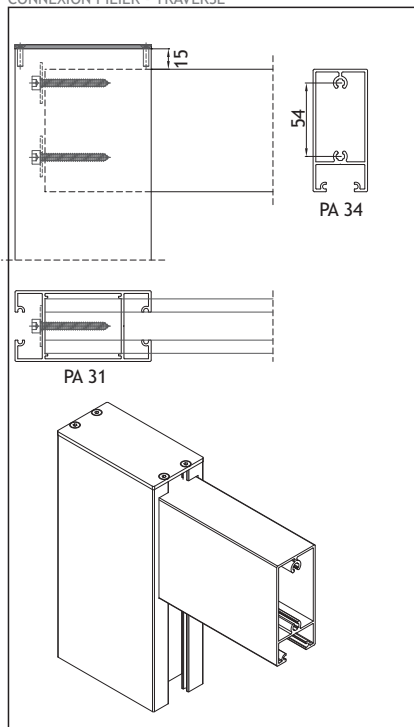

LIGAÇÃO MONTANTE PA 31 À TRAVESSA PA 34
CONNECTION COLUMN PA 31 TO TRANSOM PA 34
CONNEXION PILIER PA 31 AU TRAVERSE PA 34

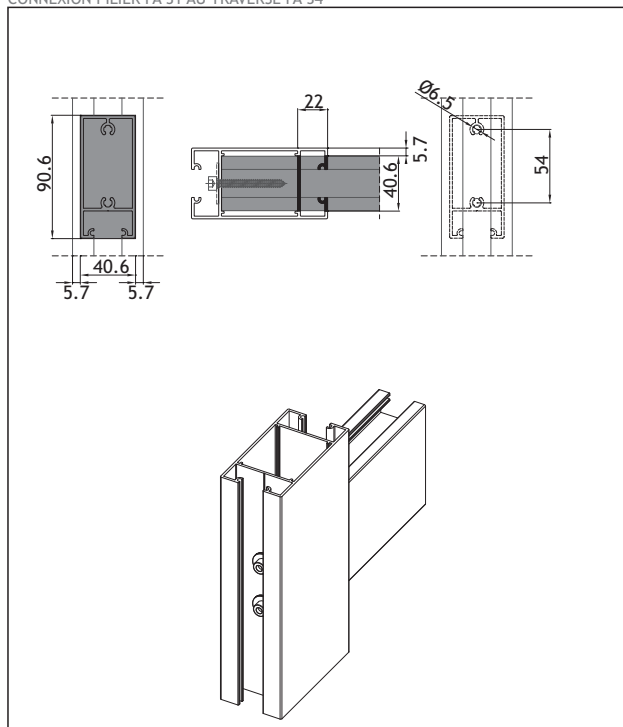

LIGAÇÃO MONTANTE - TRAVESSA INTERMÉDIA
CONNECTION COLUMN-INTERMEDIATE TRANSOM
CONNEXION PILIER - TRAVERSE INTERMÉDIAIRE

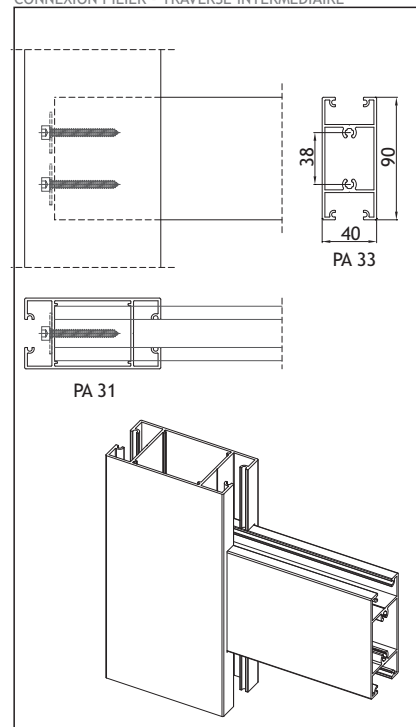

APLICAÇÃO DAS LÂMINAS PA 50
PA 50 BLADES APPLICATION
APPLICATION DES LAMES PA 50

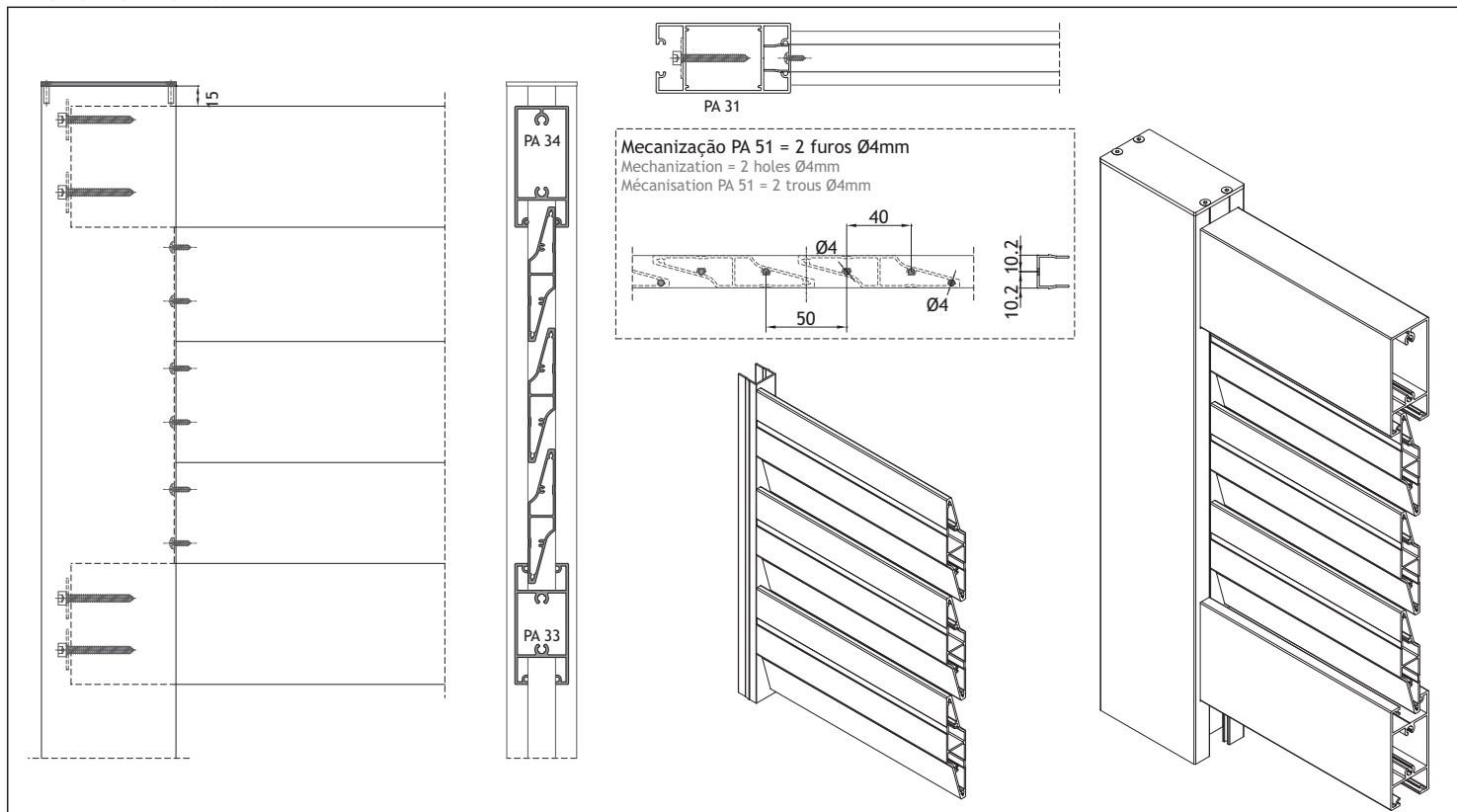

MECANIZAÇÃO DOS PERFIS - PORTÕES DE CORRER

PROFILES MECHANIZATION - SLIDING GATES

MÉCANISATION DES PROFILS - PORTAILS COULISSANTS

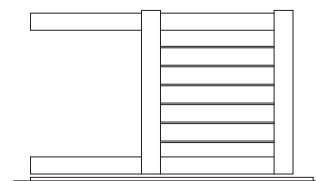

FIXAÇÃO DOS ROLAMENTOS

ROLLING BEARINGS FIXATION

FIXATION DES ROULEMENTS

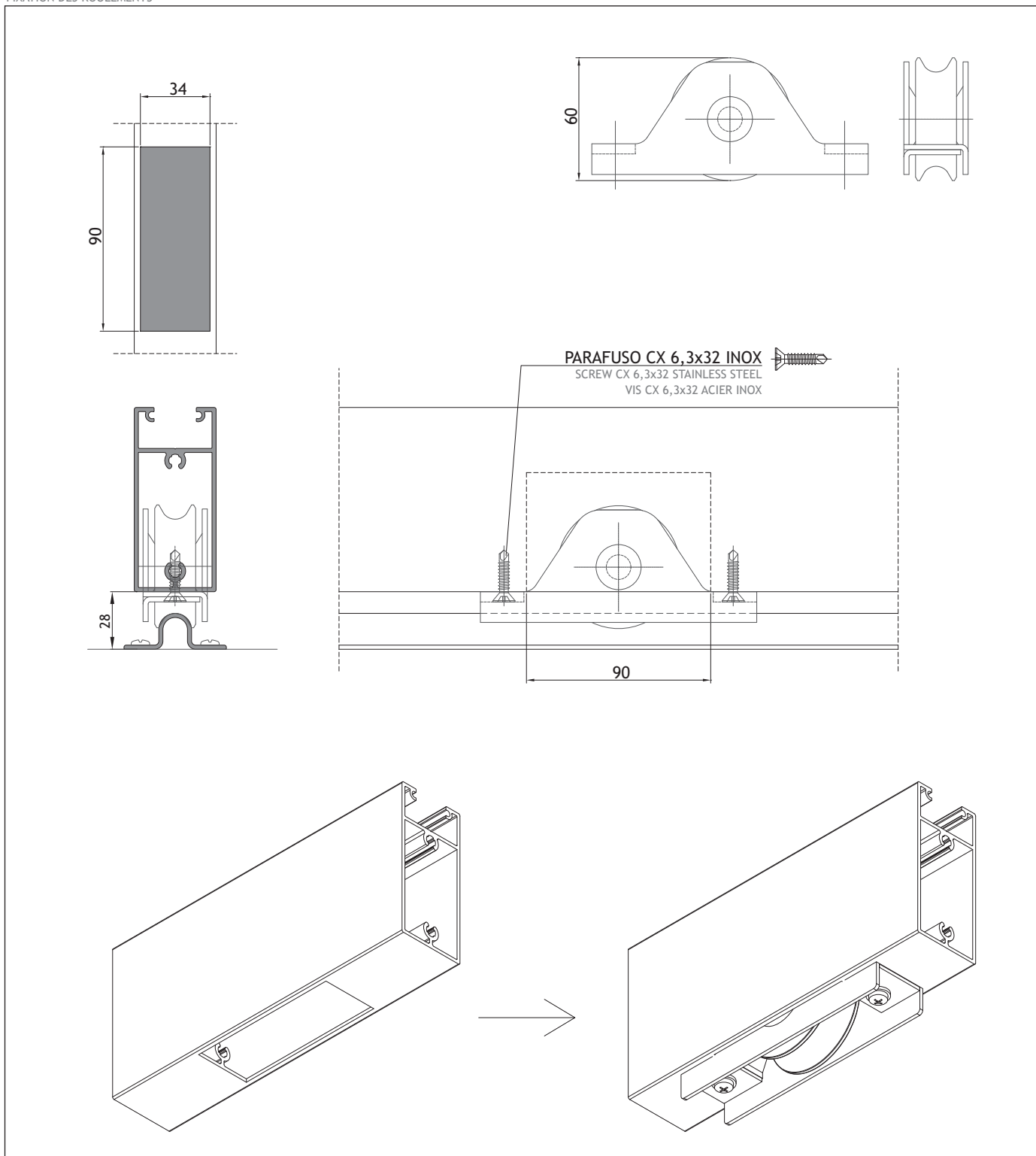

GRADEAMENTOS - LINHA RETA - MONTAGEM MODULAR

FENCES - STRAIGHT LINE - MODULAR ASSEMBLY

CLÔTURES - LIGNE DROITE - ASSEMBLAGE MODULAIRE

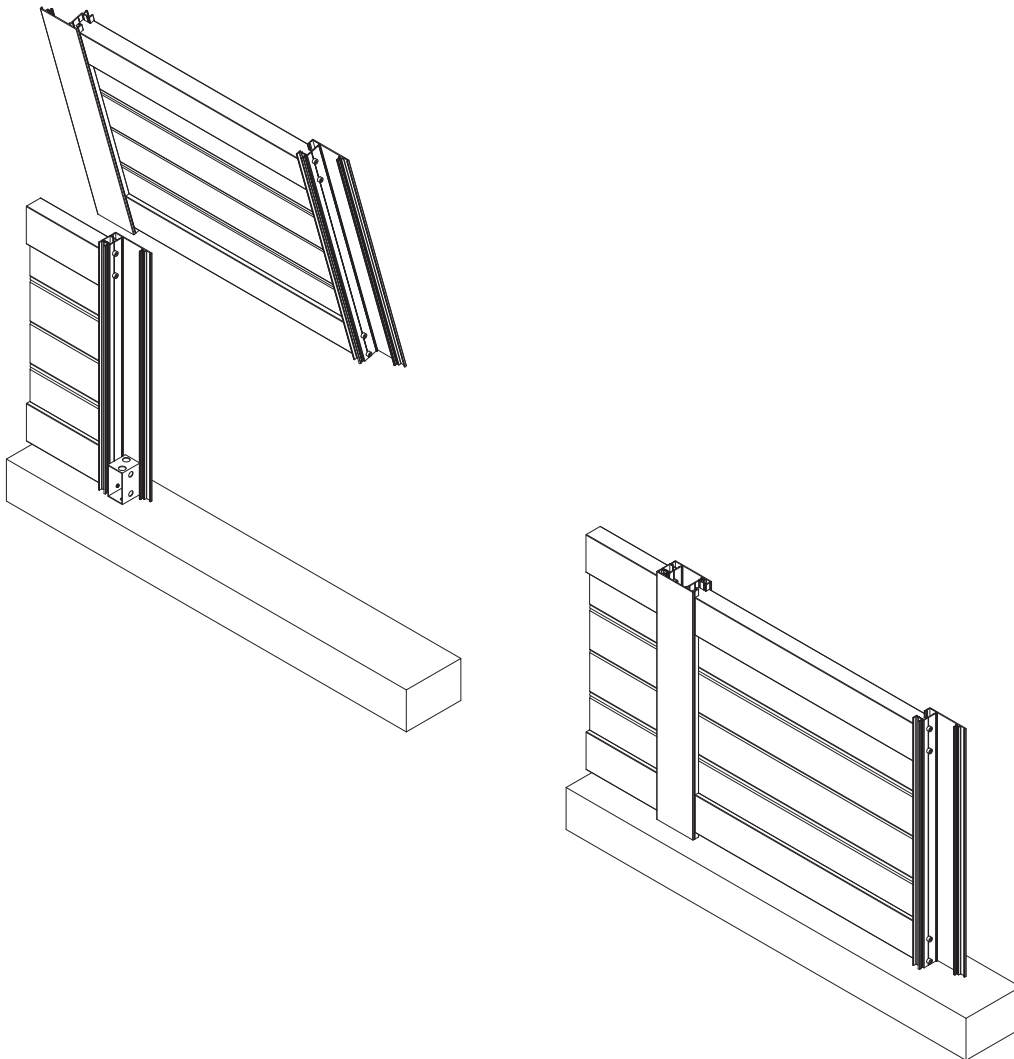

PA 61

PA 34

VD 1033

LÂMINA
BLADE
LAME

KW 23
ou | or | ou
KW 23

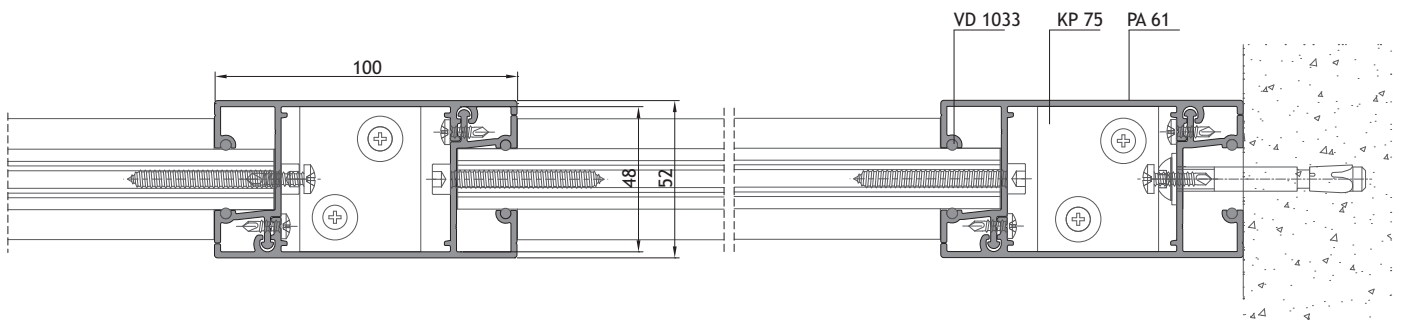
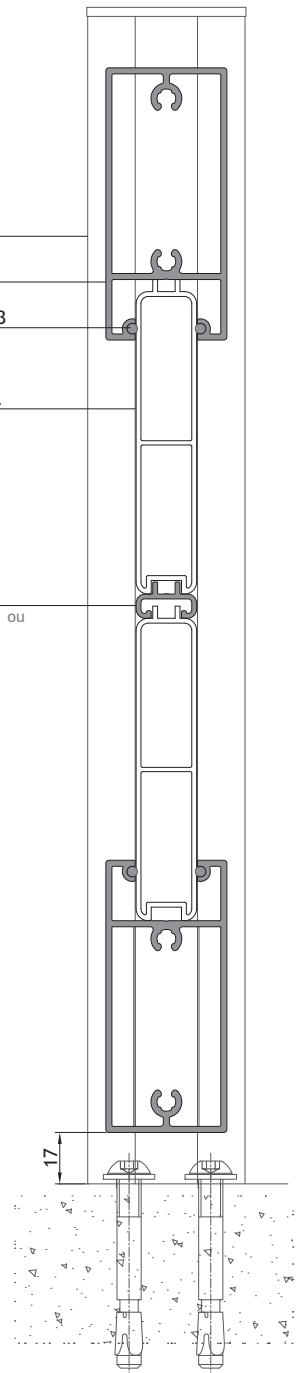

APLICAÇÃO DE VIDROS - ENCHIMENTOS

GLASS APPLICATION - FILLINGS

APPLICATION DE VERRE - REMPLISSAGE

JUNTAS DE CUNHA | GLAZING WEDGE GASKET | JOINT INTÉRIEUR

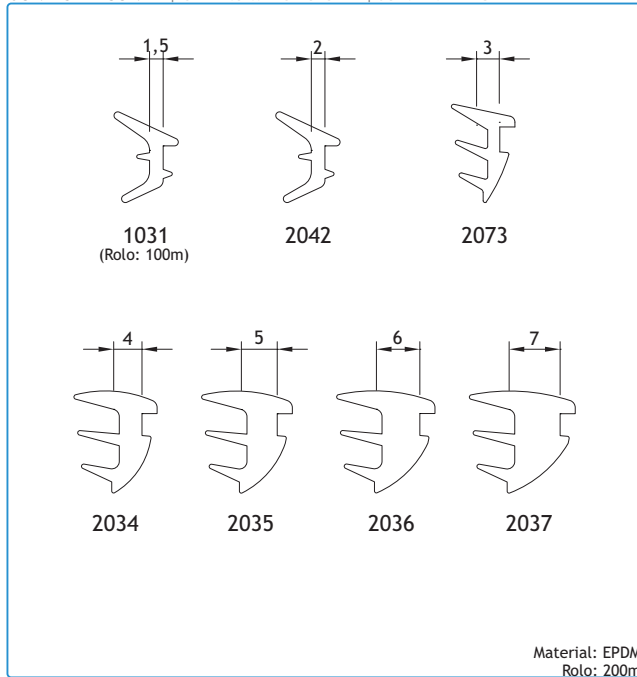

208223	JUNTA DE CUNHA 1031	208215	JUNTA DE CUNHA 2036
208191	JUNTA DE CUNHA 2042	208904	JUNTA DE CUNHA 2037
208195	JUNTA DE CUNHA 2034	208199	JUNTA DE CUNHA 2073
208196	JUNTA DE CUNHA 2035		

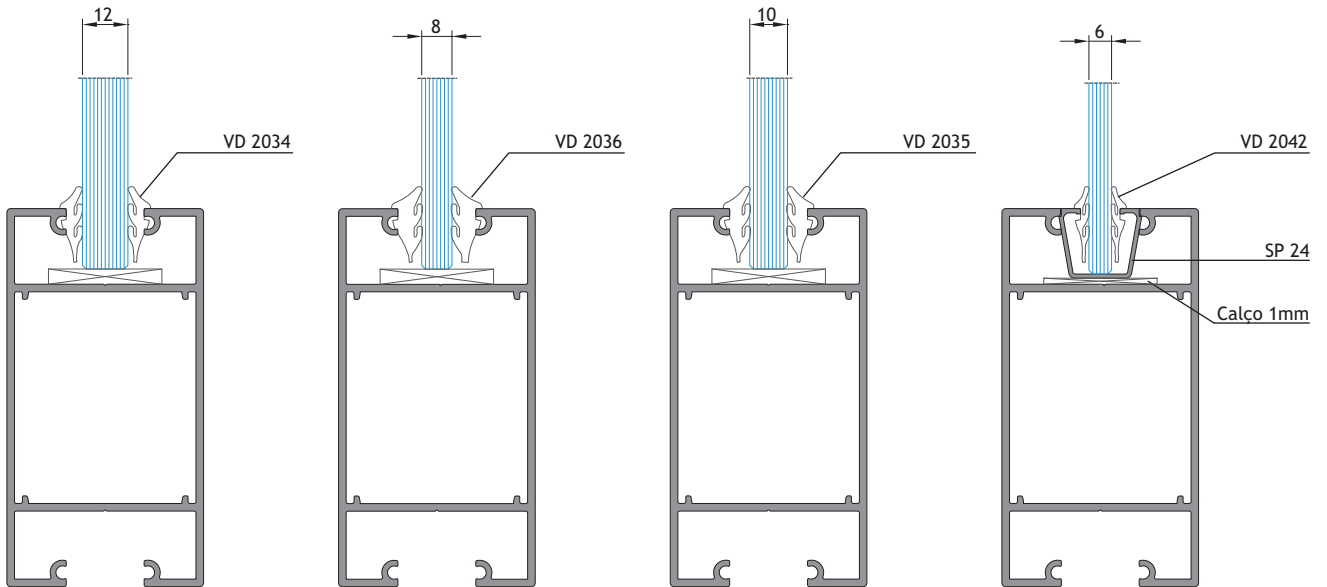

Este Catálogo poderá sofrer alterações por motivos técnicos, sem aviso prévio. Qualquer encomenda deverá ser sujeita a confirmação dos nossos serviços.

This Catalogue might be subjected to changes due to technical reasons , without previous warning. All orders must pass through the confirmation of our technical services.

Ce Catalogue pourra être modifié sans pré avis de notre part, due à des raisons techniques. Toute commande devra être confirmée par nos services.



SISTEMAS
EURO 2000®
PERFIS DE ALUMÍNIO E VIDROS PARA ARQUITECTURA

ALFA SUL

EN Lisboa-Sintra Km 14
2725-397 Mem Martins
T +351 219 265 090 | F +351 219 265 098
E alfa.sul@sosoares.pt

ALULIDER

Pavilhão Industrial H - Plataforma 13D
Zona Franca Industrial
9200-047 Caniçal - Madeira
T +351 291 960 494 | F +351 291 960 497
E alulider@sosoares.pt

METALFER

Travessa do Bolegão, 146
Apartado 1
3754-904 Fermentelos
T +351 234 729 740 | F +351 234 729 741
E metalfer@sosoares.pt

PERFIS OEIRAS

Rua da Colónia - Quinta da Cardoso
Apartado 214 - Abrunheira
2711-952 Sintra
T +351 219 156 660 | F +351 219 156 661
E perfis.oeiras@sosoares.pt

PORTALEX

Estrada de S. Marcos, 23
2735-521 Cacém
T +351 210 412 500 | F +351 210 412 507
E comercial@portalex.eu

SOSOARES

Rua do Campo Alegre, 474
4150-170 Porto
T +351 226 096 709 | F +351 226 005 642
E comercial@sosoares.pt



www.sosoares.pt



www.portalex.eu